

## Hardware 90 Series

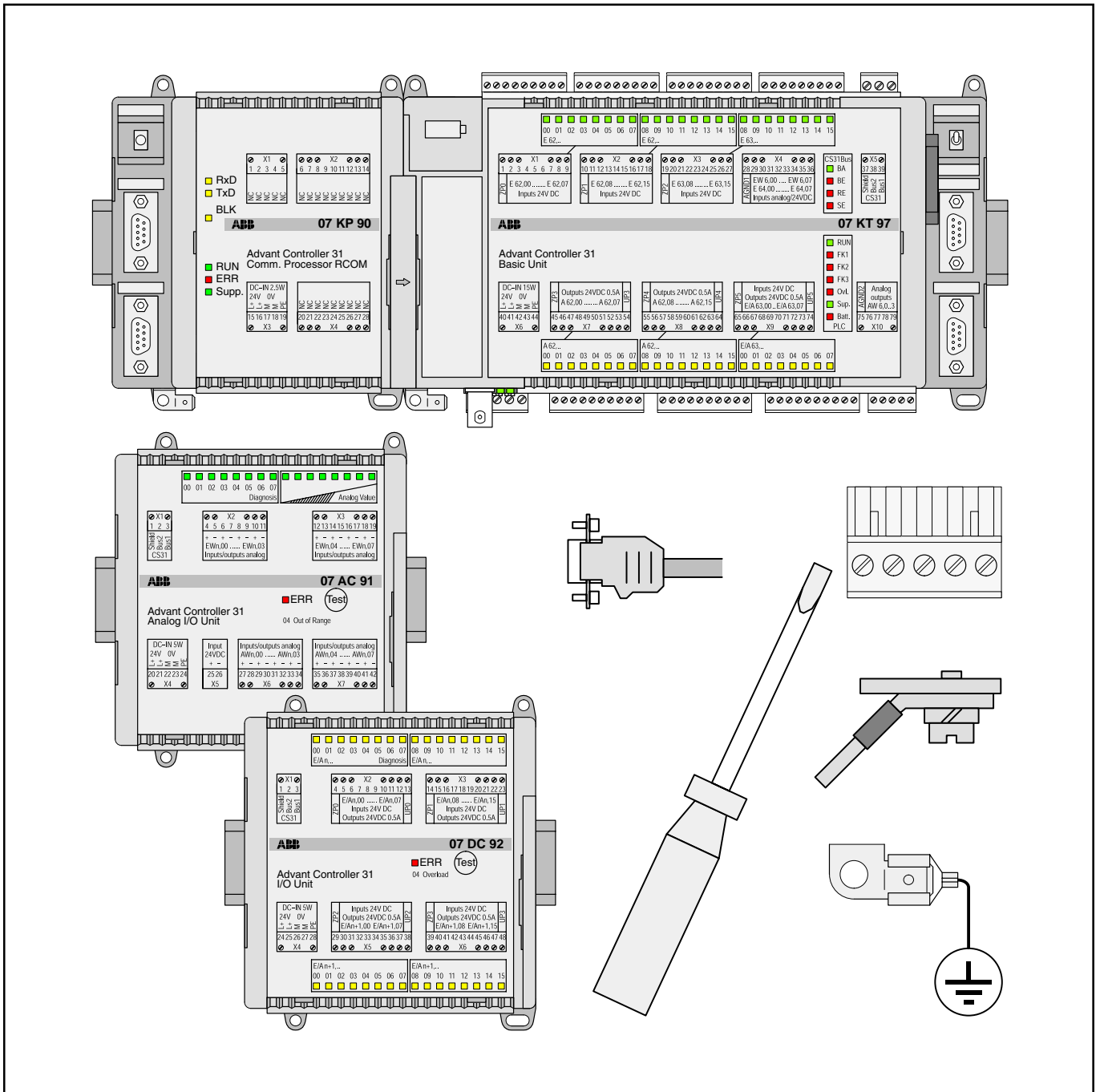



# Table of Contents (Hardware)

<b>1</b>	<b>System data and system configuration ...</b>	1- 1	<b>8</b>	unused	
1.1	System data .....	1- 1	<b>9</b>	unused	
1.2	CS31 system bus .....	1- 3			
1.3	General instructions for EMC-compatible installation .....	1- 7	<b>10</b>	<b>Interface cables .....</b>	10- 1
1.4	Check list for project planning and installation .....	1- 7	10.1	Survey table 07 SK 90...92 .....	10- 3
1.5	Bus cycle time and data security .....	1-10	10.2	Interface cable 07 SK 90 .....	10- 4
1.6	Replcacing modules on the CS31-system bus .....	1-12	10.3	Interface cable 07 SK 91 .....	10- 5
1.7	Number of user data .....	1-12	10.4	Interface cable 07 SK 92 .....	10- 6
<b>2</b>	<b>Basic units</b>		<b>11</b>	<b>Accessories .....</b>	11- 1
2.1	Basic unit 07 KT 97 (with 07 KT 96 and 07 KT 95) .....	2.1-1	11.1	Power supply unit 07 NG 32 .....	11- 3
2.2	Basic unit 07 KT 98 .....	2.2-1	11.2	Power supply unit 07 NG 34 .....	11- 5
2.3	Basic unit 07 SL 97 .....	2.3-1	11.3	Power supply unit 07 NG 35 .....	11- 8
<b>3</b>	<b>Plug-in bases</b>		11.4	Power supply unit 07 NG 36 .....	11-11
	Plug-in base ECZ .....	3.1-1	11.5	Lithium battery module 07 LE 90 .....	11-14
<b>4</b>	<b>Digital input and output modules</b>		11.6	SmartMedia Card 07 MC 90 .....	11-15
4.1	Digital input module 07 DI 92 .....	4.1-1	<b>12</b>	<b>Spare parts .....</b>	12- 1
4.2	Digital input module ICSI 08 E4 .....	4.2-1			
4.4	Digital output module ICSO 08 R1 .....	4.4-1			
4.5	Digital output module ICSO 08 Y1 .....	4.5-1			
4.7	Digital I/O-module 07 DC 91 .....	4.7-1			
4.8	Digital I/O-module 07 DC 92 .....	4.8-1			
4.10	Keyboard controller 07 TC 91 .....	4.10-1			
4.12	Digital input module 07 DI 93-I .....	4.12-1			
4.13	Digital output module 07 DO 93-I .....	4.13-1			
4.14	Digital input/output module 07 DK 93-I .....	4.14-1			
<b>5</b>	<b>Analog modules .....</b>	5- 1			
5.1	General information for the use of analog modules .....	5.1-1			
5.2	Analog input module 07 AI 91 .....	5.2-1			
5.4	Analog I/O module 07 AC 91 .....	5.4-1			
<b>6</b>	<b>Special modules .....</b>	6- 1			
6.1					
<b>7</b>	<b>Communication modules</b>				
7.1	Communication module 07 KP 90 .....	7.1-1			
7.2	Communication module 07 MK 92 .....	7.2-1			
7.3	Communication module 07 KP 93 .....	7.3-1			
7.4					
7.5					

## Hardware description 40/50 series



# 1 System Data and System Configuration

The relevant product standard for the Advant Controller 31 control system is EN 61131-2 ⇔ IEC 1131-2.

## 1.1 System data

### Operating and environmental conditions

#### Voltages

24 V DC	Process and supply voltage absolute limits ripple	24 V DC (+ 20 %, - 15 %, without ripple) 19.2 V ... 30 V incl. ripple ≤ 5 %
120 V AC	Line voltage frequency	120 V AC (+ 10 %, - 15 %) 50 Hz (+ 5 %, - 5 %) or 60 Hz (+ 5 %, - 5 %)
230 V AC	Line voltage frequency	230 V AC (+ 10 %, - 15 %) 50 Hz (+ 5 %, - 5 %) or 60 Hz (+ 5 %, - 5 %)

#### Allowed interruptions of power supply

DC supply	interruption ≤ 10 ms, time between 2 interruptions ≥ 1 s
AC supply	interruption ≤ 0.5 periods, time between 2 interruptions ≥ 1 s

#### Temperature

operating	0 °C ... + 55 °C
storage	- 25 °C ... + 75 °C
transport	- 25 °C ... + 75 °C

#### Humidity

50...95 %, without condensation

#### Air pressure operation storage

≥ 800 hPa/≤ 2000 m  
≥ 660 hPa/≤ 3500 m

### Creepage distances and clearances

The creepage distances and clearances meet Overvoltage category II, pollution degree 2

### Insulation test voltages

230 V circuits (mains, 230 V inputs/outputs) against other circuitry	2500 V
120 V circuits (mains) against other circuitry	1500 V
24 V circuits (supply, 24 V inputs/outputs), when electrically isolated against other circuitry	500 V
CS31 bus against other circuitry	500 V

### Electromagnetic compatibility

- Immunity  
against electrostatic discharge (ESD) according to EN 61000-4-2
  - electrostatic voltage in case of air discharge 8 kV
  - electrostatic voltage in case of contact discharge 4 kV

- ESD with communication connectors  
In order to prevent operating malfunctions, it is recommended, that the operating personnel discharge themselves prior to touching communication connectors or perform other suitable measures to reduce effects of electrostatic discharges.
- Immunity against the influence of radiated interference (CW radiated)
  - test field strength according to EN 61000-4-5  
10 V/m
- Immunity against transient interference voltages (burst)
  - supply voltage units (AC/DC) according to EN 61000-4-4  
2 kV
  - digital inputs/outputs (24 V DC) 1 kV
  - digital inputs/outputs (120/230 V AC) 2 kV
  - analog inputs/outputs 1 kV
  - CS31-system bus 2 kV
  - serial interfaces (COM) 0.5 kV
  - ARCnet 0.5 kV
- Immunity against the influence of line-conducted interferences (CW conducted)
  - test voltage according to EN 61000-4-6  
10 V
- Radio disturbance according to EN 55011 radio interference level A and according to EN 55022 radio interference level A (only for communication modules)

## Mechanical data

Wiring method / terminals for plug-in base ECZ	screw-type terminals for normal and Phillips-head screwdrivers, conductor cross section max. 2 x 2.5 mm <sup>2</sup>
for removable terminal blocks (big)	screw-type terminals for normal screwdrivers, conductor cross section max. 2.5 mm <sup>2</sup>
for removable terminal blocks (small)	screw-type terminals for normal screwdrivers, conductor cross section max. 1.5 mm <sup>2</sup>
Degree of protection	IP 20
Housing	according to UL 94
Vibration resistance	all three axes 10 Hz...57 Hz continuous 0.0375 mm peak 0.075 mm 57 Hz...150 Hz continuous 0.5 g peak 1.0 g
Shock test	all three axes 15 g, 11 ms, half-sinusoidal
Mounting of the modules	
DIN rail according to DIN EN 50022, only for plug-in base ECZ:	width 35 mm, depth 15 mm depths 7.5 mm and 15 mm
mounting with screws	screws with a diameter of 4 mm

## Interfaces

between the basic unit and the input/output modules,

EIA RS-485 (CS31 system bus)

for the programming units and the connection to a terminal, 9-pole D-SUB, female

EIA RS-232

## 1.2 CS31 system bus

### Wiring

#### Bus line

construction

2 cores, twisted, **with common shield**

conductor cross section recommendation

$\geq 0.22 \text{ mm}^2$  (24 AWG)

$0.5 \text{ mm}^2$ , corresponds to  $\varnothing 0.8 \text{ mm}$

twisting rate

> 10 per meter (symmetrically twisted)

core insulation

polyethylene (PE)

resistance per core

$\leq 100 \Omega / \text{km}$

characteristic impedance

approx.  $120 \Omega$  ( $100 \dots 150 \Omega$ )

Capacitance between the cores

$< 55 \text{ nF} / \text{km}$  (if higher, the max. bus length must be reduced)

terminating resistors

$120 \Omega \frac{1}{4} W$  at both line ends

bus length

max. 500 m

#### Remarks

Commonly used telephone cables with PE insulation and a core diameter of  $\geq 0.8 \text{ mm}$  are normally good.

Cables with PVC core insulation and a core diameter of  $\geq 0.8 \text{ mm}$  can be used up to a length of approx. 250 m. In this case, the bus terminating resistor is approx.  $100 \Omega$ .

## Bus configurations

A CS31 system bus always contains only one bus master (basic unit or coupler) which controls all actions on the bus. Up to 31 slaves can be connected to the bus, e.g. remote modules or slave-configured basic units.

Besides the wiring instructions shown below, the wiring and earthing instructions provided with the descriptions of the modules are valid additionally.

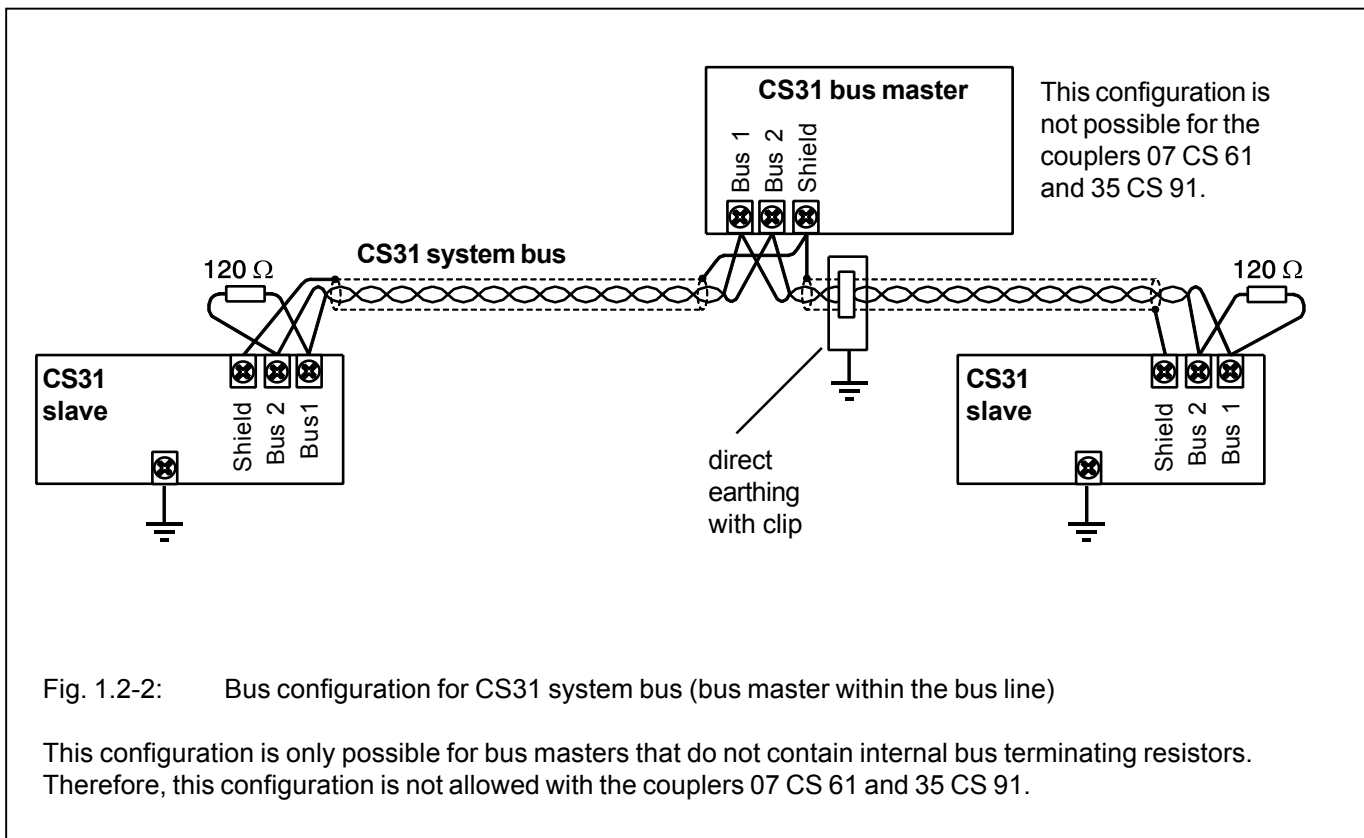
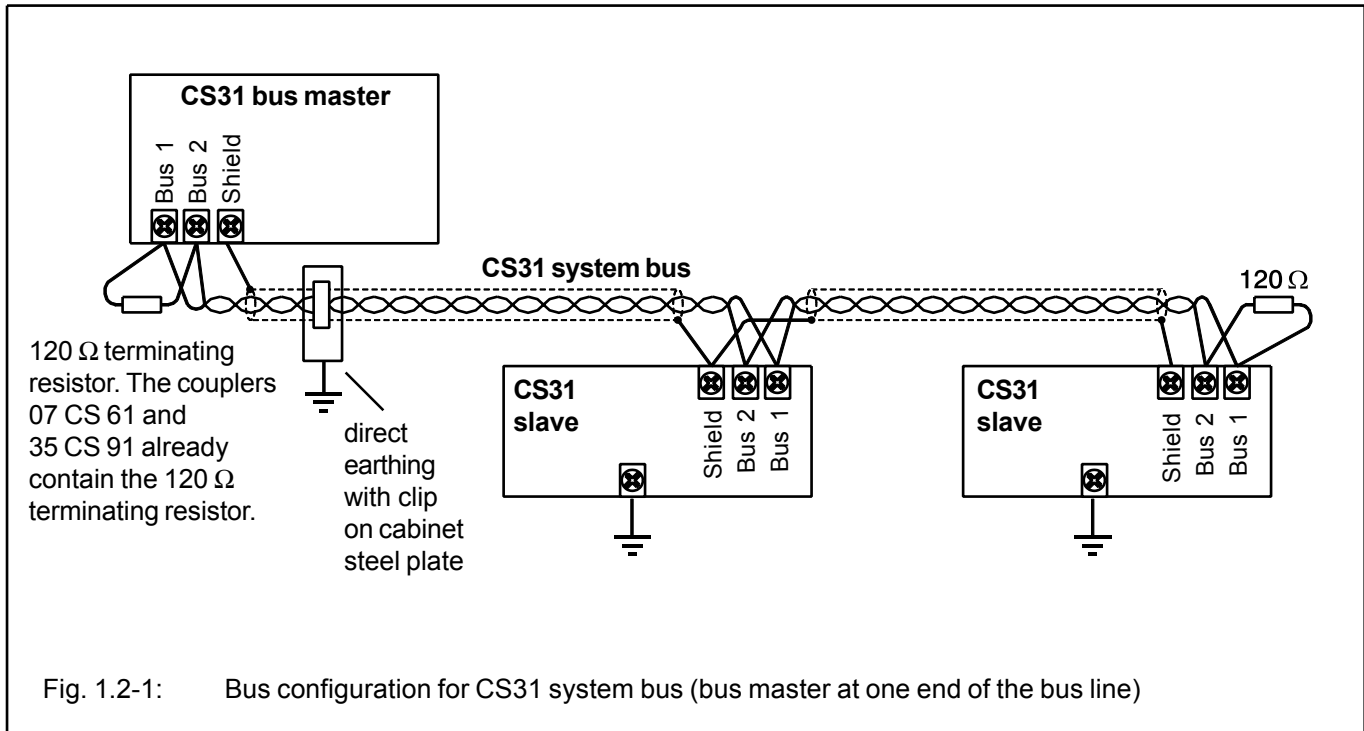



Wiring with spur lines is not allowed.

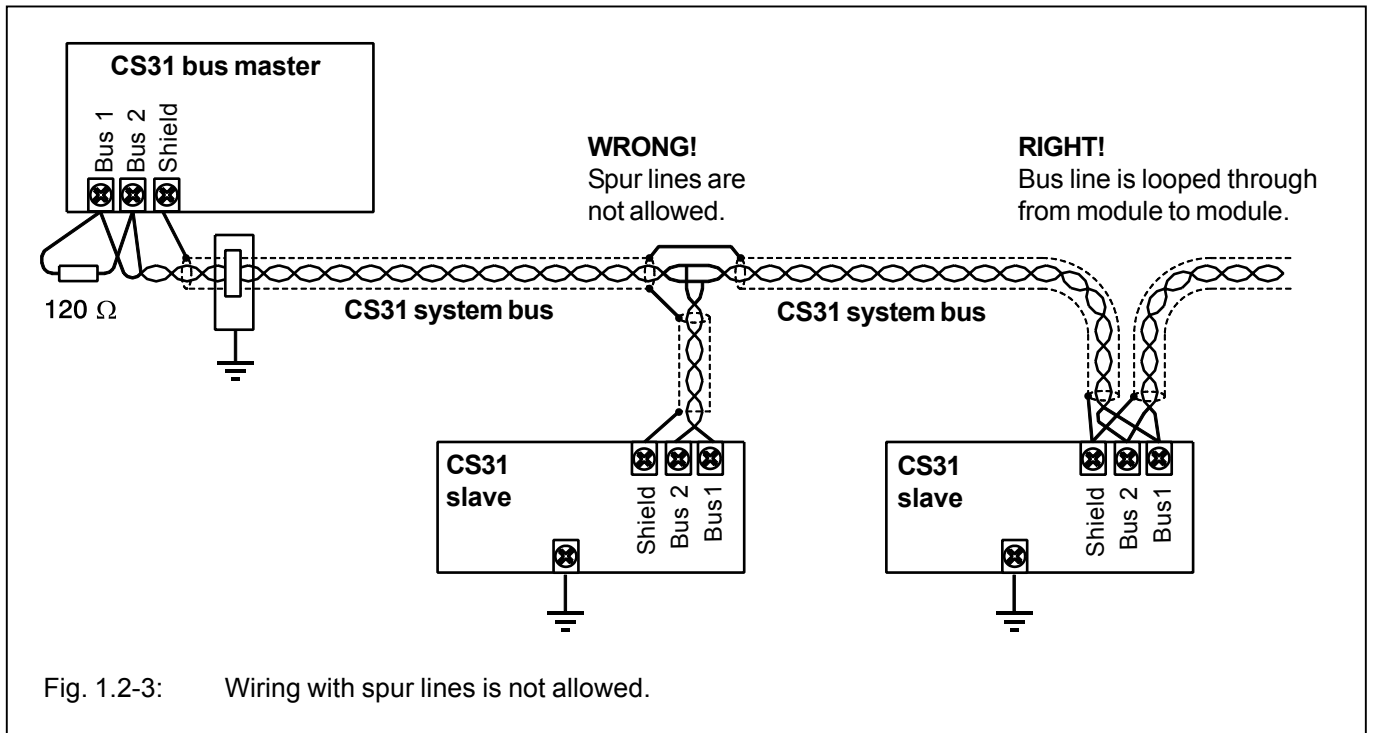

### Earthing

In order to avoid disturbance, the cable shields must be earthed directly.

Case a:

Several switch-gear cabinets: If it can be guaranteed that no potential differences can occur between the switch-gear cabinets by means of current-carrying metal connections (earthing bars, steel constructions etc.), the direct earthing is chosen.

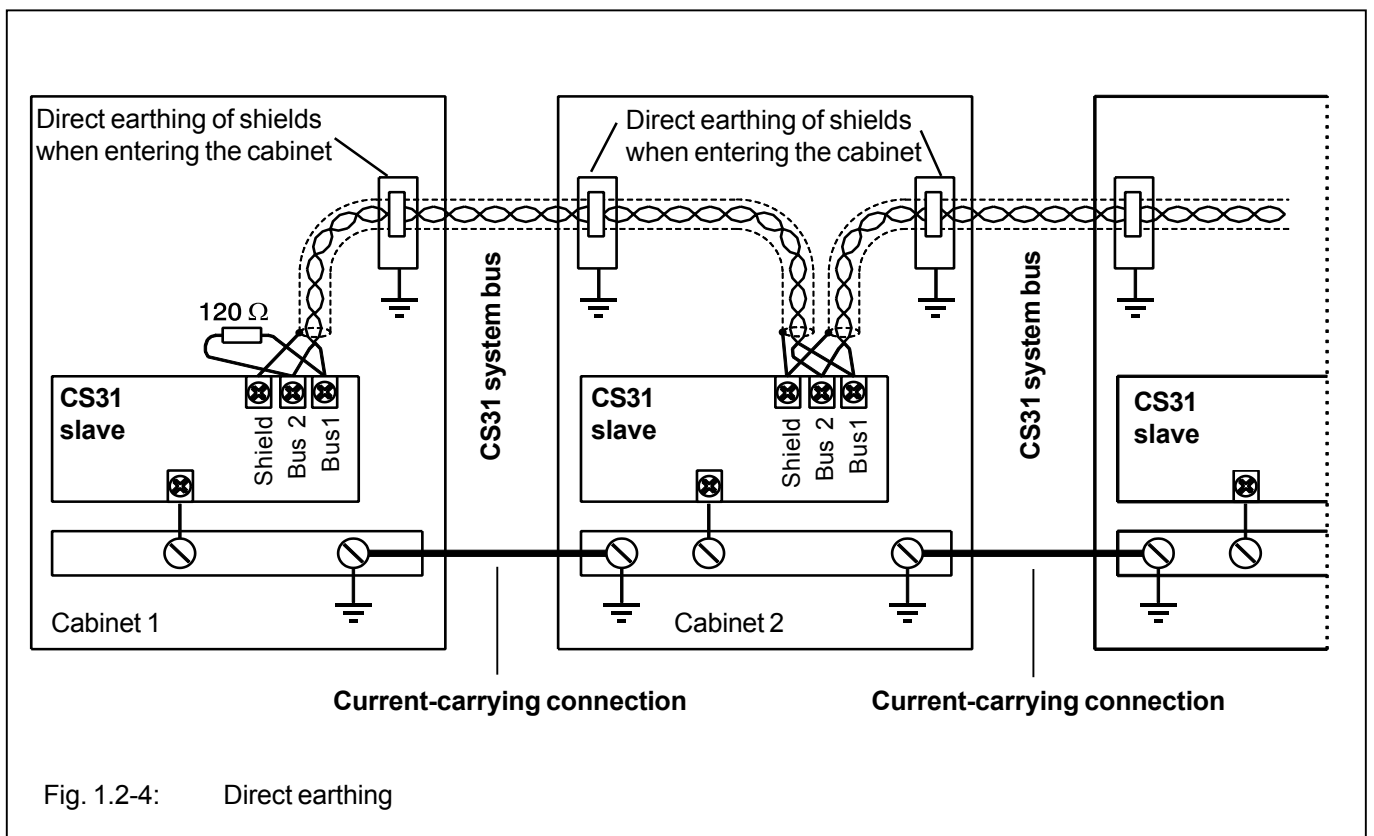

Case b:

Several switch-gear cabinets: If potential differences can occur between the switch-gear cabinets, the capacitive earthing is chosen in order to avoid circulating currents on the cable shields.

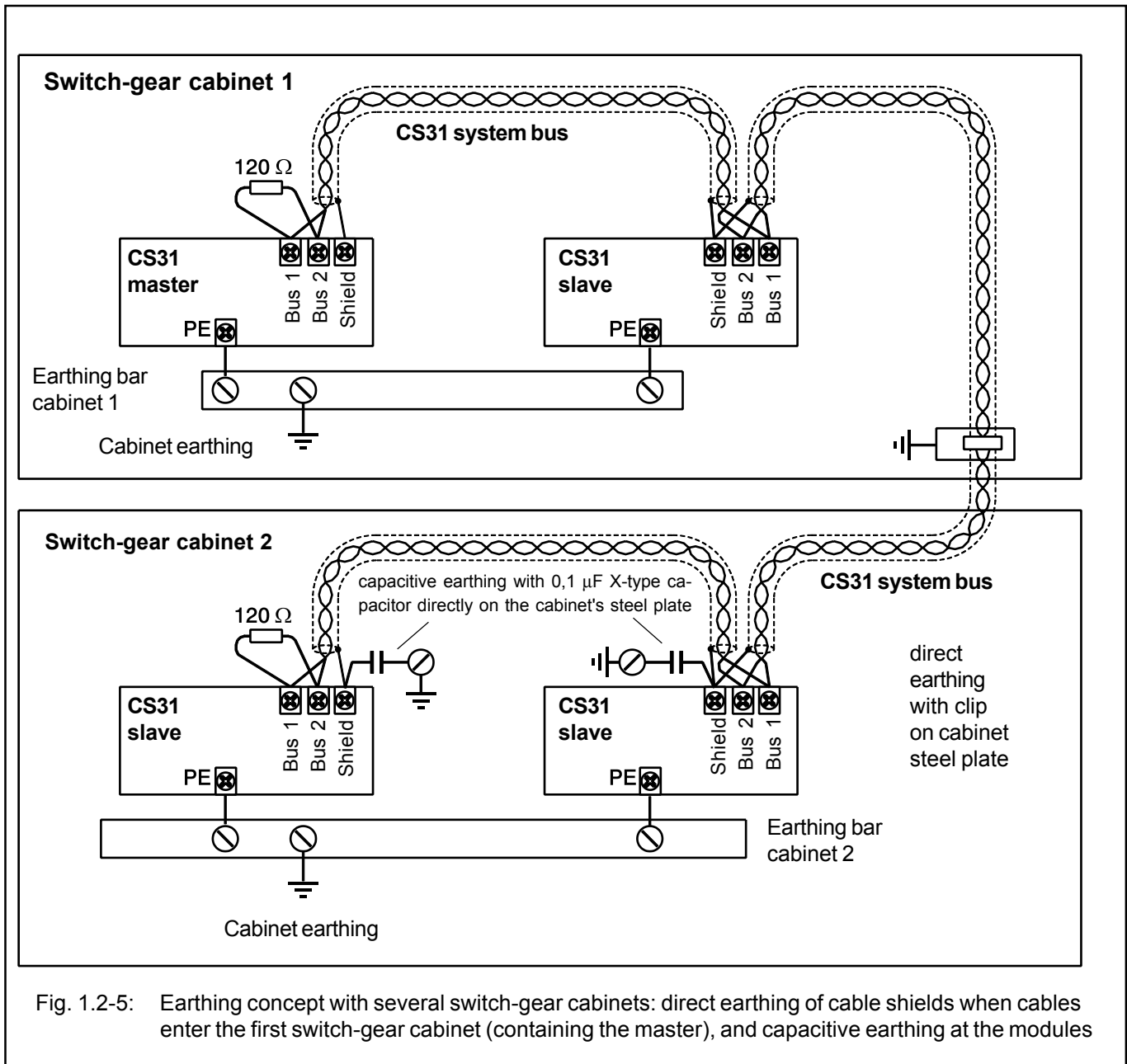

Fig. 1.2-5: Earthing concept with several switch-gear cabinets: direct earthing of cable shields when cables enter the first switch-gear cabinet (containing the master), and capacitive earthing at the modules

Note: The total length of the earthing connections shield-module and module-earthing bar must be as short as possible (max. 25 cm). The conductor cross section must be at least 2.5 mm<sup>2</sup>.

VDE 0160 requires, that the shield must be earthed directly at least once per system.

### 1.3 General instructions for EMC-compatible installation

Electric and electronic devices have to work correctly on site. This is also valid when electro-magnetic influences affect them in defined and/or expected strength. The devices themselves must not emit electro-magnetic noises.

Advant Controller components are developed and constructed so that they have a very high noise immunity. When the wiring and earthing instructions under "System data and system configuration" in volume 2 are met, an error-free operation is given.

However, there are applications where high electro-magnetic noises must be taken into due consideration already during the planning phase: e.g. when frequency converters, compressors, small-power pumps (high inductance) or medium-voltage switchgear are mounted nearby. An EMC-compatible earthing concept will also guarantee here an error-free operation.

There are three important principles to be especially considered:

- Keep all connections as short as possible (in particular the earthing conductors)
- Use large conductor cross sections (in particular for the earthing conductors)
- Create good and large-sized contacts (in particular for the earthing conductors)
  - vibration-resistant connections
  - clean metallic contact areas (remove paint, clean surfaces)
  - solid plug and screw-type connections
  - earth cable shields with clips on a well grounded metallic surface,
  - do not use sheath wires
  - do not use toothed lock washers under screwed connections

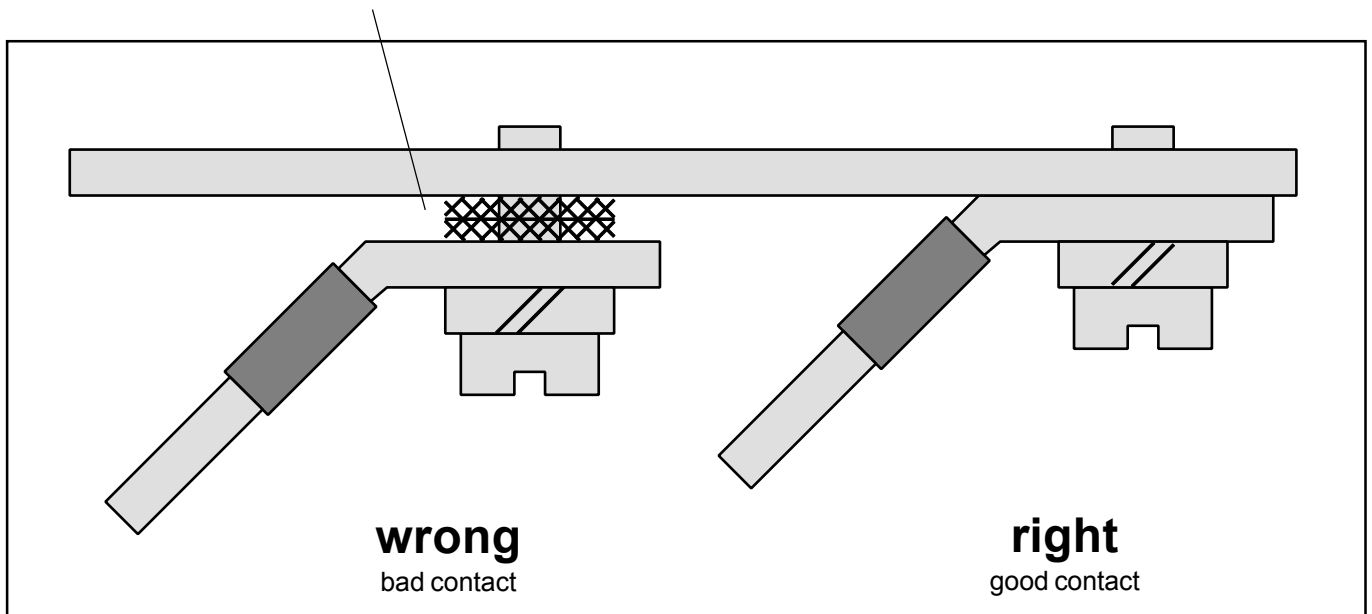

### 1.4 Check list for project planning and installation

This chapter contains a list of reminders to check whether all of the important items have been taken into consideration during planning and installation.

#### 1.4.1 Planning reserves

- Reserve inputs digital/analog for expected extensions
- Reserve outputs digital/analog for expected extensions
- Reserve space in the cabinet for expected extensions
- 

} Rule of thumb 10...20 % reserve

#### 1.4.2 Everything firmly attached

- AC31 module firmly plugged on the plug-in base (all screws fastened)
- 

#### 1.4.3 Everything correctly set

- Operating modes correctly set on the modules (e.g. DIL switch)
- Correct input/output terminals on the modules used (e.g. voltage inputs or outputs on the analog modules)
- Addresses correctly set
- 

#### 1.4.4 Laying cables

- Power cables (230/400 V) laid out separately from the control cables (24 V, analog signals), whenever possible with a distance of 20 cm or more
- Sufficient conductor cross sections
- Sufficient cable insulation / cable shielding
- Supply lines of the power supply connected to the central units with flanged couplers (e.g. 07 KT 97 with 07 KP 90)
  - The supply lines are first connected to the central unit (07 KT 97), and then looped to the coupler (07 KP 90), see the descriptions of the coupler.
- 

#### 1.4.5 PE connection

- Infeed of earthing potential to the PE bar with large conductor cross section
- Connection of the PE bar to the mounting steel plate
- Connection of the switchgear cabinet components to each other
- Connection of movable switchgear components to PE (doors)
- PE Faston connection of central units and couplers (see module descriptions)
- CS31 bus shield to PE
- Connections between analog cable shields and PE
- Reference potentials of the output voltages of the power supply units are interconnected and grounded
- 

#### 1.4.6 CS31 System bus (see also volume 2, system data, system design)

- Bus line is looped through from module to module
- no spur lines
- Bus length (max. 500 m, measure cable length before installation, when necessary)
- Bus terminating resistors (see system data)
- Bus terminals (BUS1 to BUS1, BUS2 to BUS2)
- 
-

#### 1.4.7 Power supplies

- All mains voltages of the switchgear cabinet correctly fed in and fused
- All power supply units correctly fed in and fused
- Tolerances and load capacities of the power supply units sufficient
- Ripple of the power supply units low enough
- Reference potentials of the output voltages of the power supply units are interconnected and grounded
- 
- 

#### 1.4.8 Connection of inductive loads to binary outputs

- Inductive DC loads wired with free-wheeling diodes
- Inductive AC loads wired with snubbers
- 

#### 1.4.9 Wiring of unused analog inputs (and outputs)

- Unused analog inputs wired according to module data sheets  
see also volume 2, chapter 5.2, Analog input modules
  - to avoid error message, inputs 4-20 mA supplied with at least 4 mA
  - voltage inputs 0-10 V and/or -10...+10 V connected to Analog GND
  - to avoid error message, Pt100 inputs wired with 120  $\Omega$
  - to avoid error message, Pt1000 inputs wired with 1200  $\Omega$
  - thermocouple inputs short-circuited
- Analog outputs not overloaded
- Unused analog voltage outputs left open. Unused current outputs can be short-circuited to Analog GND to e.g. avoid error messages
- 
- 

#### 1.4.10 Programming / commissioning

- Operating mode of the basic units (master, slave, stand-alone) correctly set (default setting is stand-alone)
- Software configuration for the modules correctly programmed
- Program sent to the basic unit
- Program saved in Flash EPROM
- Operating mode of the PLC enabled (Power OFF/ON, warm start, cold start)
- 
-

## 1.5 Bus cycle time and data security

### Bus cycle time

In the following, the bus cycle time  $t_B$  is introduced. The reaction time from terminal to terminal is the sum of several delays and is described with the basic units. The bus cycle time consist of:

- Base time 2 ms  
During this time the basic unit performs a diagnosis and looks for new remote modules.

- Bus transmission time per module, depends on the type of module (see next page).
- Equation for the bus cycle time of the AC31 modules:

Bus cycle time  $t_B$  = sum of the bus transmission times of the modules + base time (2 ms)

Module	Bus transmission time in $\mu\text{s}$
Digital input modules	
ICSI 08 D1	323
ICSI 08 E1	323
ICSI 08 E3	323
ICSI 08 E4	323
ICSI 16 D1	387
ICSI 16 E1	387
Digital output modules	
ICSO 08 R1	260
ICSO 08 Y1	260
ICSO 16 N1	340
Digital input/output modules	
ICSC 08 L1	387
ICFC 16 L1	516
ICSK 20 F1	452
ICSK 20 N1	452
07 DC 91 / ICDG 32 L1	516/590 (depending on configuration)
07 DI 92	516
07 DC 92	750/516 (depending on configuration)
IP65-I/O modules	
07 DK 93-I	387
07 DO 93-I	260
07 DI 93-I	387
Analog modules	
ICSM 06 A6	1162
ICSE 08 A6	1355
ICSE 08 B5	1355
ICSA 04 B5	700
ICST 08 A8	1355
ICST 08 A9	1355
07 AI 91 / ICDT 08 B5	1355
07 AC 91	2500
Couplers	
ICBG32L7	516
ICBG64L7	750
High-speed counter	
ICSF 08 D1	1300
Safety-related modules	
07 DI 90-S / 07 EB 90-S	590
07 DO 90-S / 07 AB 90-S	750
07 AI 90-S / 07 EA 90-S	1050

Module	Bus transmission time in $\mu\text{s}$
Keyboard/LED controller module 07 TC 90/91, TCK 64 16 E/A 32 E/A	387 750
Basic units as slaves	
07 KR 31 / 07 KT 31	516 * 1)
07 KR 91 / KT 92 bis KT 98	750 * 2)
* = default	
Typ. settings	
1) Send 2 bytes + receive 2 bytes (1 word)	516
2) Send 4 bytes + receive 4 bytes (2 words)	750
Send 8 bytes + receive 8 bytes (4 words)	1300
Send 12 bytes + receive 12 bytes (6 words)	1850
Send 8 words + receive 8 words	2500

For system bus-compatible modules from other companies, the bus cycle times are provided with the modules.

Example: 8 modules of 07 DI 92 are used. For one 07 DI 92 a bus transmission time of 516  $\mu$ s is given in the table. The bus cycle time is now calculated as  
 $t_B = 8 \cdot 516 \mu\text{s} + 2 \text{ ms} = 6.1 \text{ ms}$ .

### Data security

The transmission protocol serves for max. 31 slaves (remote I/O modules) plus one master - the basic unit.

During the initialization cycle the bus master searches for all the slaves and gets in this way the number and types of the found modules.

All telegrams terminate with a CRC8 check word. Error security of the bus is Hamming distance 4.

All the messages have the following format:

Request of the basic unit:

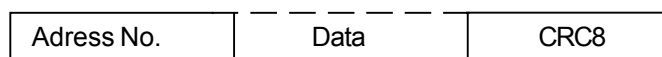

Answer of an I/O module:

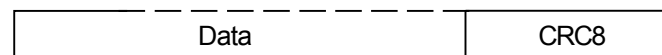

In every cycle, the bus master addresses all existing modules one after the other, performs diagnostic functions and checks for new installed modules. In this way diagnosis is carried out continuously, the networking is always checked for correct function and new installed modules are detected quickly.

If a basic unit or a module detects a difference between a received CRC and its self-calculated CRC, the concerned telegram is ignored.

A bus error exists when 10 messages are wrong in sequence. For reactions see the descriptions of the the basic units and the couplers.

## 1.6 Replacing modules on the CS31 system bus

- Check the DIL switch settings.
- After replacing a module, the new module will be adopted into the bus cycle by the basic unit or by the coupler automatically. If a module is replaced while the system is running, some error flags may remain set. They can, for instance, be reset with power off/on of the basic unit.

## 1.7 Number of user data

The following table shows, how many user data (in bytes) the modules **send to the master** or **receive from the master**.

Module	sends	receives	type
ICSI 08...	1	0	0
ICSI 16...	2	0	0
ICSO 08...	0	1	2
ICSO 16...	0	2	2
ICSC 08...	1	1	4
ICSC 16...	2	2	4
ICSK 20...	2	1	4
07 DC 91 (ICDG 32 L1)	* 2	2	4
	3	2	4
07 DI 92	4	0	0
07 DC 92	* 4	4	4
	0	4	2
07 DK 93 -I	1	1	4
07 DO 93 -I	0	1	2
07 DI 93 -I	2	0	0
07 TC 91 / 07 TC 90 (TCK 64) *	2	2	4
	4	4	4
ICSE 08...	16	0	1
ICST 08...	16	0	1
07 AI 91 (ICDT 08 B5)	16	0	1
ICSA 04 B5	0	8	3
ICSM 06 A6	8	4	5
07 AC 91	12 bits	* 16	5
	8 bits	16	5
		16	1
		0	16
		16	3
ICSF 08 D1	10	6	5
07 AI 90-S (07 EA 90-S)	12	0	1
07 DO 90-S (07 AB 90-S)	4	4	4
07 DI 90-S (07 EB 90-S)	5	0	0

\* depends on configuration

Types: 0 = Digital input  
 1 = Analog input word  
 2 = Digital output  
 3 = Analog output word  
 4 = Digital input/output  
 5 = Analog input/output word



# 2 Basic Units

---

- 2.1 **Basic unit 07 KT 97** (with 07 KT 96 and 07 KT 95) ..... 2.1-1
- 2.2 **Basic unit 07 KT 98** ..... 2.2-1
- 2.3 **Basic unit 07 SL 97** ..... 2.3-1



# Advant Controller 31 Intelligent Decentralized Automation System

## Basic Units

07 KT 97, 07 KT 96, 07 KT 95

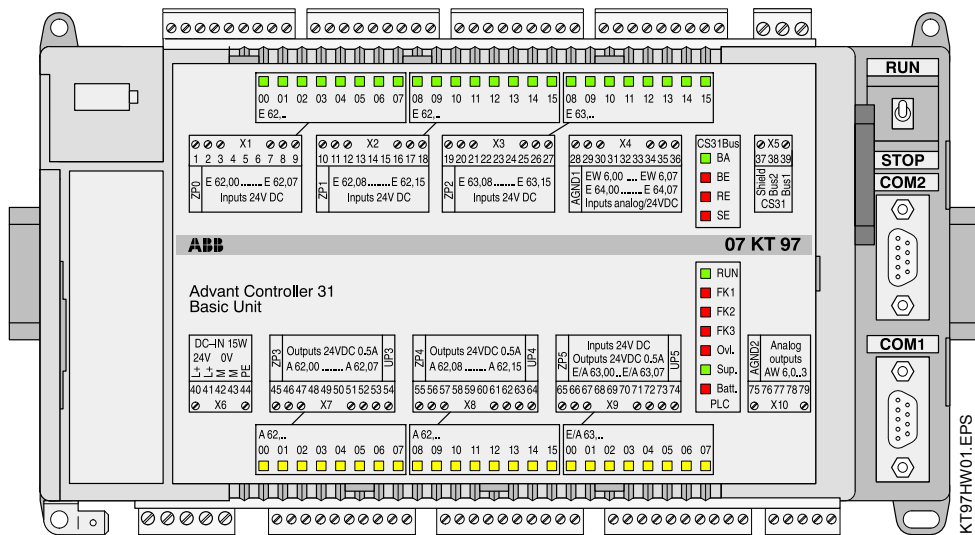



## 2.1 Basic Unit 07 KT 97

Basic unit with max. 480 kB user program  
+ 256 kB user data, CS31 system bus

The basic unit **07 KT 97 R200** is the standard device for all applications. In addition, there are basic units with reduced performance (e.g. **07 KT 95** or **07 KT 96**) as well as ones with extended performance (e.g. **07 KT 97 R260** with ARCNET connection, **07 KT 97 R0220** with PROFIBUS connection and **07 KT 97 R0262** with both ARCNET and PROFIBUS connection). A comparison table is given on page 3. This document describes the basic unit **07 KT 97 R200** and then adds the data sheets of the other devices which only show the differences.

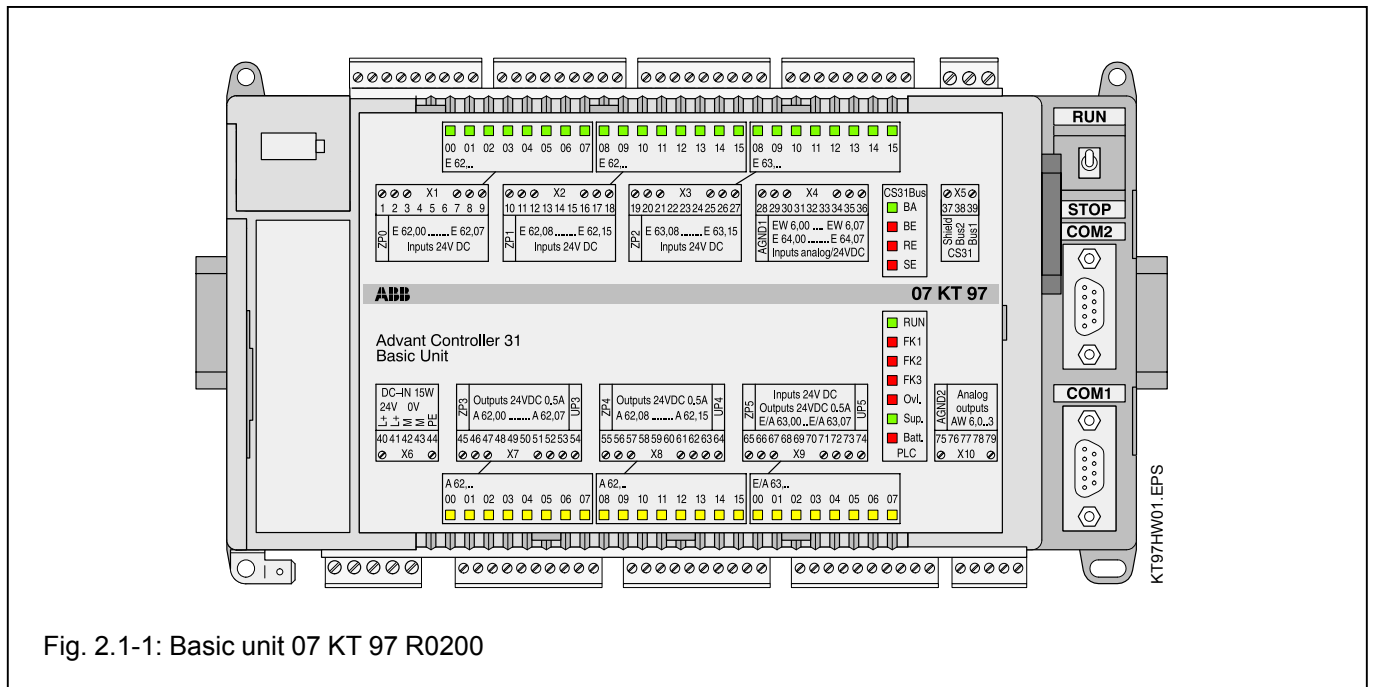

Fig. 2.1-1: Basic unit 07 KT 97 R200

### Contents

<b>2.1.1</b>	<b>Brief description</b> .....	page 2.1-4
2.1.1.1	Main features .....	4
2.1.1.2	Project planning / Start-up .....	4
<b>2.1.2</b>	<b>Front view</b> .....	5
<b>2.1.3</b>	<b>Structure of the front panel</b> .....	6
2.1.3.1	Terminal assignment overview .....	7
<b>2.1.4</b>	<b>Electrical connection</b> .....	8
2.1.4.1	Application example for input and output wiring .....	8
2.1.4.2	Connection of the supply voltage .....	9
2.1.4.3	Connection of the CS31 system bus .....	9
2.1.4.4	Connection of the digital inputs .....	10
2.1.4.5	Connection of the digital outputs .....	11
2.1.4.6	Connection of the digital inputs/outputs ....	12
2.1.4.7	Connection of the 8 configurable analog inputs .....	13
2.1.4.8	Connection of the 4 configurable analog outputs .....	20
2.1.4.9	Battery and battery replacement .....	21
2.1.4.10	Serial interface COM1 .....	21
2.1.4.11	Serial interface COM2 .....	22
2.1.4.12	Networking interface .....	22
<b>2.1.5</b>	<b>SmartMedia Card</b> .....	23

<b>2.1.6</b>	<b>High-speed counter</b> .....	page 2.1-24
<b>2.1.7</b>	<b>Technical data 07 KT 97</b> .....	25
2.1.7.1	General data .....	25
2.1.7.2	Power supply .....	25
2.1.7.3	Lithium battery .....	26
2.1.7.4	Digital inputs .....	26
2.1.7.5	Digital outputs .....	26
2.1.7.6	Digital inputs/outputs .....	27
2.1.7.7	Analog inputs .....	27
2.1.7.8	Analog outputs .....	28
2.1.7.9	Connection of the serial interfaces COM1 and COM2 .....	29
2.1.7.10	Connection of the CS31 system bus .....	29
2.1.7.12	LED displays .....	30
2.1.7.13	High-speed hardware counter .....	30
2.1.7.14	Mechanical data .....	31
2.1.7.15	Mounting hints .....	31
2.1.7.16	Ordering data .....	32
<b>2.1.8</b>	<b>Data sheet 07 KT 95</b> .....	33
<b>2.1.9</b>	<b>Data sheet 07 KT 96</b> .....	35
<b>2.1.11</b>	<b>ARCNET</b> .....	37
<b>2.1.12</b>	<b>PROFIBUS-DP</b> .....	41
<b>2.1.13</b>	<b>CANopen</b> .....	44
<b>2.1.14</b>	<b>Ethernet</b> .....	47

## Functionality of the basic units 07 KT 97

User program	480 kB
User data	256 kB (Flash EPROM)
Digital inputs	24 in 3 groups of 8 each, electrically isolated
Digital outputs	16 transistor outputs in 2 groups of 8 each, electrically isolated
Digital inputs/outputs	8 in 1 group, electrically isolated
Analog inputs	8 in 1 group, individually configurable to 0...10 V, 0...5 V, +10 V, +5 V, 0...20 mA, 4...20 mA, Pt100 (2-wire or 3-wire), differential inputs, digital inputs
Analog outputs	4 in 1 group, individually configurable to 0...10 V, 0...20 mA, 4...20 mA
Serial interfaces	COM1, COM 2 as MODBUS interfaces and for programming and test functions
Parallel interfaces for connection of couplers	07 KP 90 (RCOM), 07 KP 93 (2 x MODBUS), 07 MK 92 (freely programmable)
System bus interface	CS31
Integrated couplers	see next page
High-speed counter	integrated, many functions configurable
Real-time clock	integrated
SmartMedia Card	memory medium for operating system, user program and user data
LED displays	for signal conditions, operating statuses and error messages
Power supply voltage	24 V DC
Data backup	with lithium battery 07 LE 90
Programming software	907 AC 1131

### Differences between the basic units 07 KT 95 to 07 KT 98

Basic unit	07 KT 95	07 KT 96	07 KT 97	07 KT 98		
Number of digital inputs	12	24	24	24		
Number of digital outputs	8	16	16	16		
No. of digital inputs/outputs	-	-	8	8		
Number of analog inputs	4	-	8	8		
Pt100	no	-	yes	yes		
Number of analog outputs	2	-	4	4		
20 mA	no	-	yes	yes		
Are the analog inputs configurable as digital inputs?	no	-	yes	yes		
Terminals 20 to 27	- - -	E 63,00 to E 63,07	E 63,08 to E 63,15	E 63,08 to E 63,15		
Processing time, 65 % bits, 35 % words, for 1 kB of program, typ.	0.3 ms	0.3 ms	0.3 ms	0.07 ms		
Order number	GJR5 2528 00 R....	GJR5 2529 00 R....	GJR5 2530 00 R....	GJR5 2531 00 R....		

### Available versions of the basic units 07 KT 95 to 07 KT 98

Version of the basic unit	Integrated (internal) couplers	Version is available with			
		07 KT 95	07 KT 96	07 KT 97	07 KT 98
R0100, R0200	none	◆	◆	◆	
R0120, R0220	PROFIBUS-DP			◆	◆
R0160, R0260	ARCNET			◆	◆
R0162, R0262	ARCNET + PROFIBUS-DP			◆	◆
R0268	ARCNET + CANopen				◆
R0270	Ethernet			◆	◆
R0272	Ethernet + PROFIBUS-DP			◆	◆
R0276	Ethernet + ARCNET			◆	◆
R0277	Ethernet + Ethernet			◆	◆
R0278	Ethernet + CANopen			◆	◆
R0280	CANopen			◆	◆

### Usable SmartMedia Cards

Version of the basic unit	Usable SmartMedia Card	
	07 MC 90, 5 V GJR5 2526 00 R0101	07 MC 90, 3.3 V GJR5 2526 00 R0201
R0100 to R0199	◆	
R0200 to R0299	◆	◆

## 2.1.1 Brief description

The basic unit 07 KT 97 works either as

- bus master in the decentralized automation system Advant Controller 31 or as
- slave (remote processor) in the decentralized automation system Advant Controller 31 or as
- stand-alone basic unit.

The basic unit is powered by 24 V DC.

### 2.1.1.1 Main features

- 24 digital inputs with LED displays
- 16 digital transistor outputs with LED displays
- 8 digital inputs/outputs with LED displays
- 8 **individually configurable** analog inputs 0...10 V, 0...5 V,  $\pm 10$  V,  $\pm 5$  V, 0...20 mA, 4...20 mA, differential inputs, Pt100 (2-wire or 3-wire), the analog inputs are also individually configurable as digital inputs
- 4 **individually configurable** analog outputs  $\pm 10$  V, 0...20 mA, 4...20 mA
- 2 counters for counting frequencies up to 50 kHz, configurable in 7 different operating modes
- 1 CS31 system bus interface for system expansion
- 1 interface for connecting communication modules (e.g. 07 KP 90)
- 2 serial interfaces COM1, COM2
  - as MODBUS interfaces and
  - for programming and test functions
- Real-time clock
- LEDs for displaying operating conditions and error messages
- Detachable screw-type terminal blocks
- Fastening by screws or by snapping the device onto a DIN rail
- The lithium battery 07 LE 90 can be put into the battery compartment in order to
  - store and backup the user program in the RAM
  - store and backup data which is additionally contained in the RAM, e.g. the status of flags
  - backup the time and date (real-time clock)
- RUN/STOP switch for starting and aborting the program execution
- Extensive diagnosis functions
  - self-diagnosis of the basic unit
  - diagnosis of the CS31 system bus and the connected modules

- Integrated Flash EPROM for storing program and data
- Exchangeable SmartMedia Card 07 MC 90 for user data or for updating the operating system or PLC program

### 2.1.1.2 Project planning / start-up

The following has to be observed for project planning and start-up:

- Programming is performed with AC31 programming software, which can be run on commercially available IBM compatible PCs (see documentation of the programming system 907 AC 1131).
- Online program modification  
A quick modification of the user program is possible without interrupting the operation (see programming system 907 AC 1131).
- Possible operating modes
  - Stand-alone basic unit
  - Bus master basic unit
  - Slave basic unit
- Backup of data areas, i.e. saving of data during power OFF/ON, is possible with an integrated battery and/or by storing them in the Flash EPROM.





## 2.1.3 Structure of the front panel

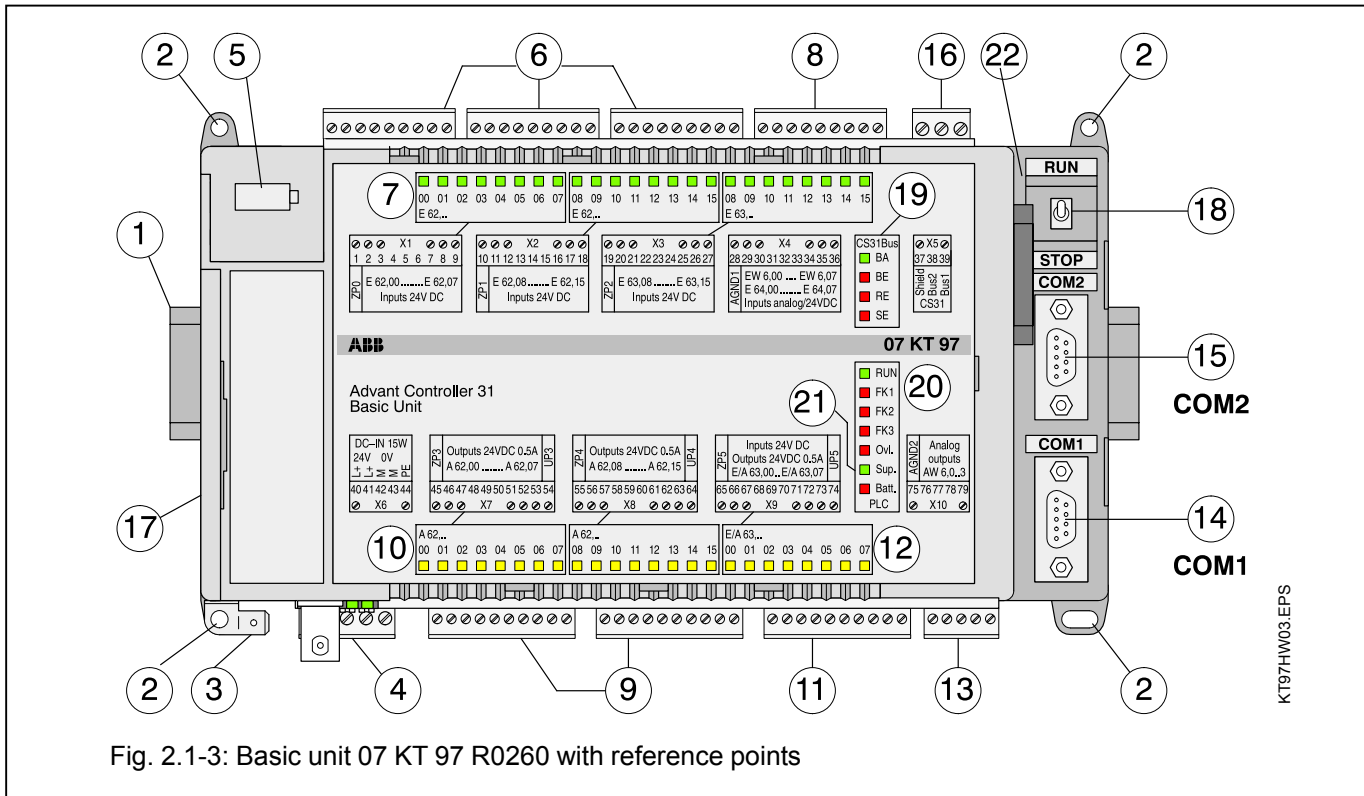

Fig. 2.1-3: Basic unit 07 KT 97 R0260 with reference points

- |  |   |                                     |           |            |    |         |           |    |         |                   |    |         |                   |     |           |                        |     |         |             |     |         |               |     |         |             |           |         |                                     |        |           |                          |         |         |                            |
|--|---|-------------------------------------|-----------|------------|----|---------|-----------|----|---------|-------------------|----|---------|-------------------|-----|-----------|------------------------|-----|---------|-------------|-----|---------|---------------|-----|---------|-------------|-----------|---------|-------------------------------------|--------|-----------|--------------------------|---------|---------|----------------------------|
| <p>(1) Fastening the device on DIN rail</p> <p>(2) Fastening the device by screws</p> <p>(3) Faston earthing terminal 6.3 mm</p> <p>(4) Supply voltage connection 24 V DC</p> <p>(5) Battery compartment</p> <p>(6) 24 digital inputs in 3 groups</p> <p>(7) 24 green LEDs for the digital inputs</p> <p>(8) 8 individually configurable analog inputs in one group 0...10 V, 0...5 V, <math>\pm 10</math> V, <math>\pm 5</math> V, 0...20 mA, 4...20 mA, Pt100 (2-wire or 3-wire), differential inputs, the analog inputs are also individually configurable as digital inputs</p> <p>(9) 16 digital transistor outputs in two groups</p> <p>(10) 16 yellow LEDs for the digital outputs</p> <p>(11) 8 digital inputs/outputs in one group</p> <p>(12) 8 yellow LEDs for the digital inputs/outputs</p> <p>(13) 4 individually configurable analog outputs <math>\pm 10</math> V, 0...20 mA, 4...20 mA in one group</p> <p>(14) Serial interface COM1 (programming, MMC)</p> <p>(15) Serial interface COM2 (programming, MMC)</p> | <p>(16) Connection for CS31 system bus</p> <p>(17) Cover of the interface for the connection of communication modules (may only be removed for connecting communication modules)</p> <p>(18) Switch for RUN/STOP operation:<br/>With the RUN/STOP switch the execution of the user program is started or stopped.</p> <p>(19) LED displays for CS31 system bus<br/> <table border="0" style="margin-left: 20px;"> <tr> <td>BA</td> <td>LED green</td> <td>Bus active</td> </tr> <tr> <td>BE</td> <td>LED red</td> <td>Bus error</td> </tr> <tr> <td>RE</td> <td>LED red</td> <td>Remote unit error</td> </tr> <tr> <td>SE</td> <td>LED red</td> <td>Serial unit error</td> </tr> </table> </p> <p>(20) LED displays for RUN and error class<br/> <table border="0" style="margin-left: 20px;"> <tr> <td>RUN</td> <td>LED green</td> <td>User progr. is running</td> </tr> <tr> <td>FK1</td> <td>LED red</td> <td>Fatal error</td> </tr> <tr> <td>FK2</td> <td>LED red</td> <td>Serious error</td> </tr> <tr> <td>FK3</td> <td>LED red</td> <td>Light error</td> </tr> </table> </p> <p>(21) Other LED displays<br/> <table border="0" style="margin-left: 20px;"> <tr> <td>Over-load</td> <td>LED red</td> <td>Overload/short-circuit at an output</td> </tr> <tr> <td>Supply</td> <td>LED green</td> <td>Supply voltage available</td> </tr> <tr> <td>Battery</td> <td>LED red</td> <td>Batt. <b>not</b> effective</td> </tr> </table> </p> <p>(22) Insertable SmartMedia Card 07 MC 90 for operating system, user program and user data</p> | BA                                  | LED green | Bus active | BE | LED red | Bus error | RE | LED red | Remote unit error | SE | LED red | Serial unit error | RUN | LED green | User progr. is running | FK1 | LED red | Fatal error | FK2 | LED red | Serious error | FK3 | LED red | Light error | Over-load | LED red | Overload/short-circuit at an output | Supply | LED green | Supply voltage available | Battery | LED red | Batt. <b>not</b> effective |
| BA   | LED green   | Bus active                          |           |            |    |         |           |    |         |                   |    |         |                   |     |           |                        |     |         |             |     |         |               |     |         |             |           |         |                                     |        |           |                          |         |         |                            |
| BE   | LED red   | Bus error                           |           |            |    |         |           |    |         |                   |    |         |                   |     |           |                        |     |         |             |     |         |               |     |         |             |           |         |                                     |        |           |                          |         |         |                            |
| RE   | LED red   | Remote unit error                   |           |            |    |         |           |    |         |                   |    |         |                   |     |           |                        |     |         |             |     |         |               |     |         |             |           |         |                                     |        |           |                          |         |         |                            |
| SE   | LED red   | Serial unit error                   |           |            |    |         |           |    |         |                   |    |         |                   |     |           |                        |     |         |             |     |         |               |     |         |             |           |         |                                     |        |           |                          |         |         |                            |
| RUN  | LED green   | User progr. is running              |           |            |    |         |           |    |         |                   |    |         |                   |     |           |                        |     |         |             |     |         |               |     |         |             |           |         |                                     |        |           |                          |         |         |                            |
| FK1  | LED red   | Fatal error                         |           |            |    |         |           |    |         |                   |    |         |                   |     |           |                        |     |         |             |     |         |               |     |         |             |           |         |                                     |        |           |                          |         |         |                            |
| FK2  | LED red   | Serious error                       |           |            |    |         |           |    |         |                   |    |         |                   |     |           |                        |     |         |             |     |         |               |     |         |             |           |         |                                     |        |           |                          |         |         |                            |
| FK3  | LED red   | Light error                         |           |            |    |         |           |    |         |                   |    |         |                   |     |           |                        |     |         |             |     |         |               |     |         |             |           |         |                                     |        |           |                          |         |         |                            |
| Over-load  | LED red   | Overload/short-circuit at an output |           |            |    |         |           |    |         |                   |    |         |                   |     |           |                        |     |         |             |     |         |               |     |         |             |           |         |                                     |        |           |                          |         |         |                            |
| Supply   | LED green   | Supply voltage available            |           |            |    |         |           |    |         |                   |    |         |                   |     |           |                        |     |         |             |     |         |               |     |         |             |           |         |                                     |        |           |                          |         |         |                            |
| Battery  | LED red   | Batt. <b>not</b> effective          |           |            |    |         |           |    |         |                   |    |         |                   |     |           |                        |     |         |             |     |         |               |     |         |             |           |         |                                     |        |           |                          |         |         |                            |

### 2.1.3.1 Terminal assignment overview

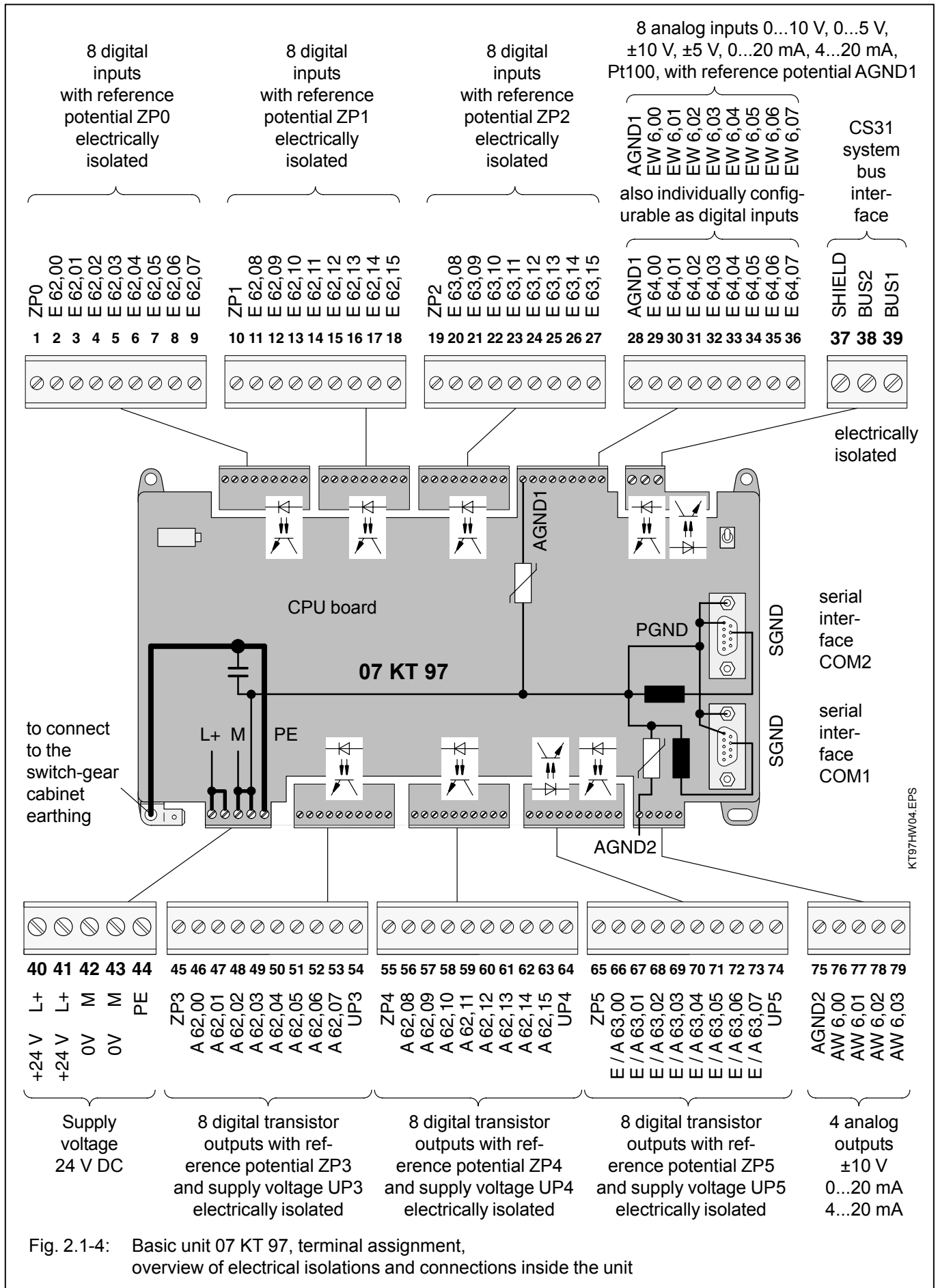

Fig. 2.1-4: Basic unit 07 KT 97, terminal assignment, overview of electrical isolations and connections inside the unit

## 2.1.4 Electrical connection

### 2.1.4.1 Application example for input and output wiring

The following illustration shows an application example in which different possibilities for wiring inputs and outputs are used.

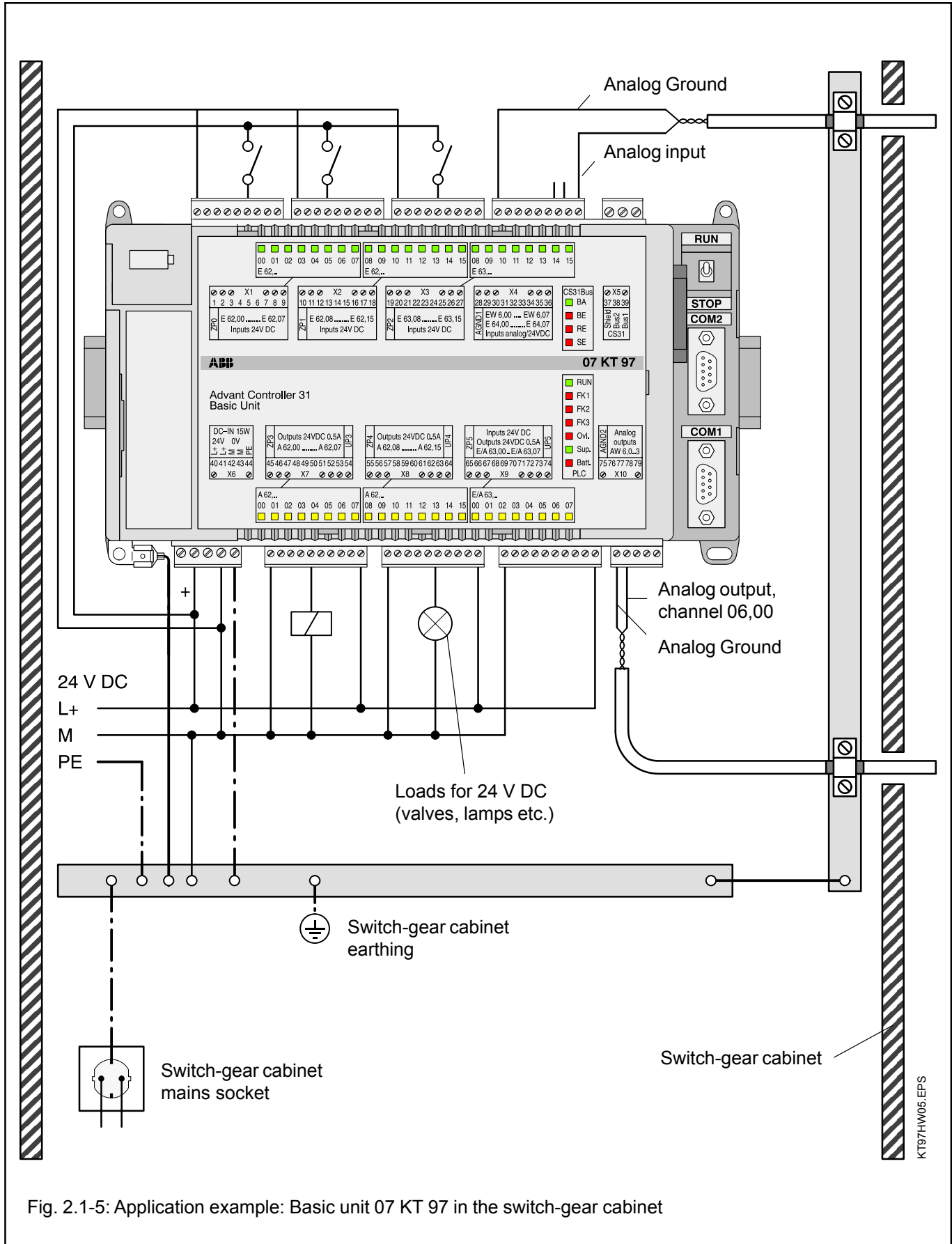

Fig. 2.1-5: Application example: Basic unit 07 KT 97 in the switch-gear cabinet

Please observe in particular:

- The earthing measures
- The handling of the electrically isolated input groups
- The handling of the electrically isolated output groups
- The connection of shielded analog cables
- The earthing of the switch-gear cabinet mains socket

#### 2.1.4.2 Connection of the supply voltage

The 24 V DC supply voltage is connected via a 5-pole detachable screw-type terminal block.

**Attention: Plug and unplug terminal block only with power is off!**

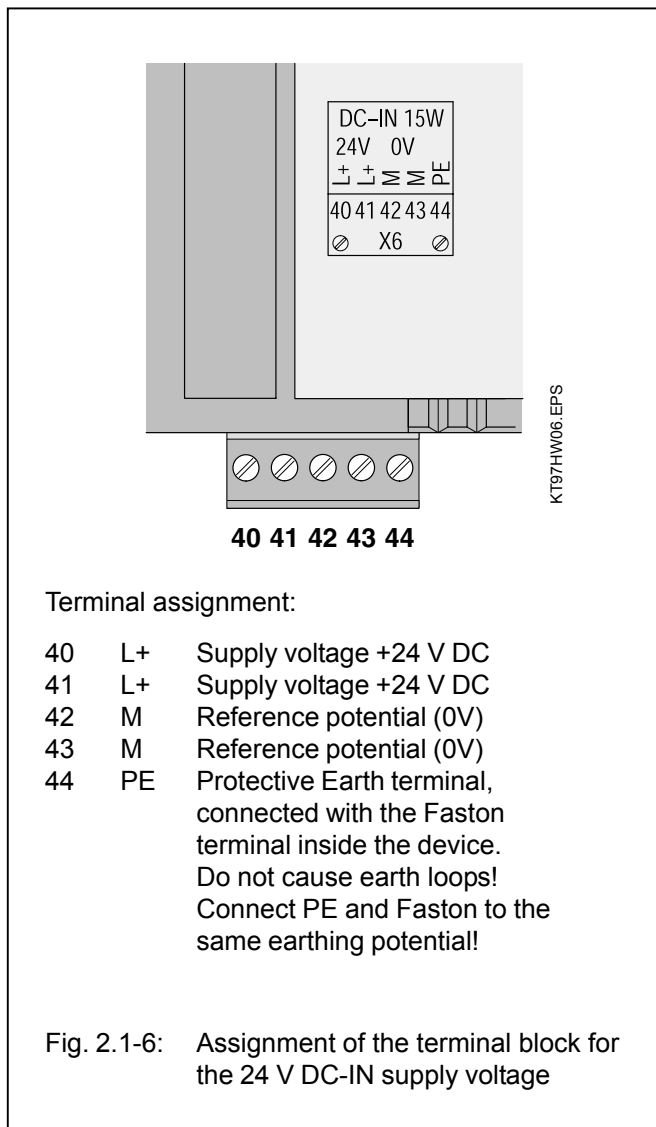

The terminals 40 and 41 (L+) as well as 42 and 43 (M) are connected to each other via the printed circuit board. If the power supply is looped through, these two connections must not be burdened with currents higher than **4 A**.

Please take also into consideration that supply voltages which are looped through are disconnected for the following devices when the plug is withdrawn.

If higher currents are to be conducted without interruption possibility, the two wires for M have to be connected under the same terminal. The same applies for L+.

#### 2.1.4.3 Connection for the CS31 system bus

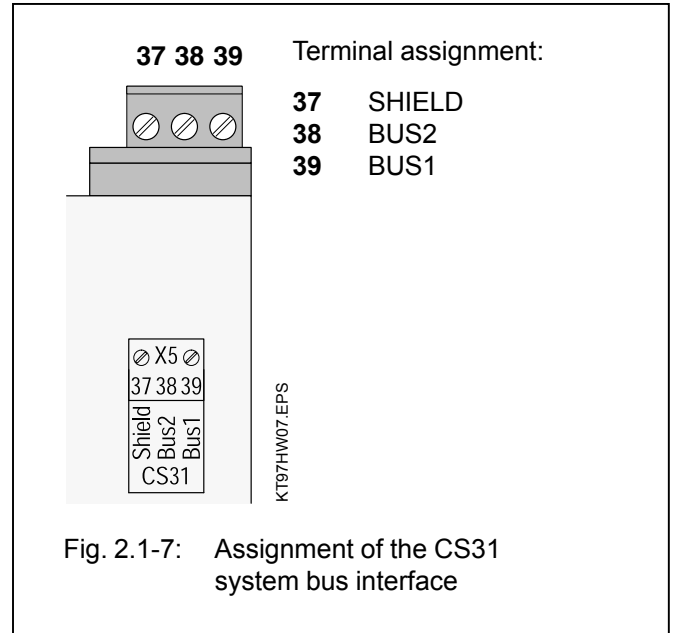

The connection to the CS31 system bus is made by means of a 3-pole detachable terminal block. Please observe:

- All of the AC31 devices, no matter whether they are master or slave devices, are connected with twisted-pair bus line as follows:
  - One core of the bus line is looped through via the BUS1 terminals of all devices to be connected to the CS31 system bus.
  - The other core of the bus line is looped through via the BUS2 terminals of all devices to be connected to the CS31 system bus.
- If the basic unit 07 KT 97 is located at the beginning or at the end of the bus line, the bus terminating resistor (120 Ω) has to be connected additionally between the BUS1 and BUS2 terminals.
- The shield of the twisted-pair bus line is looped through via the SHIELD terminals of all the devices to be connected to the CS31 system bus.
- The handling of the CS31 system bus is described in detail in volume 2, System data.

### 2.1.4.4 Connection of the digital inputs

The following figure shows the assignment of the 24 digital inputs.

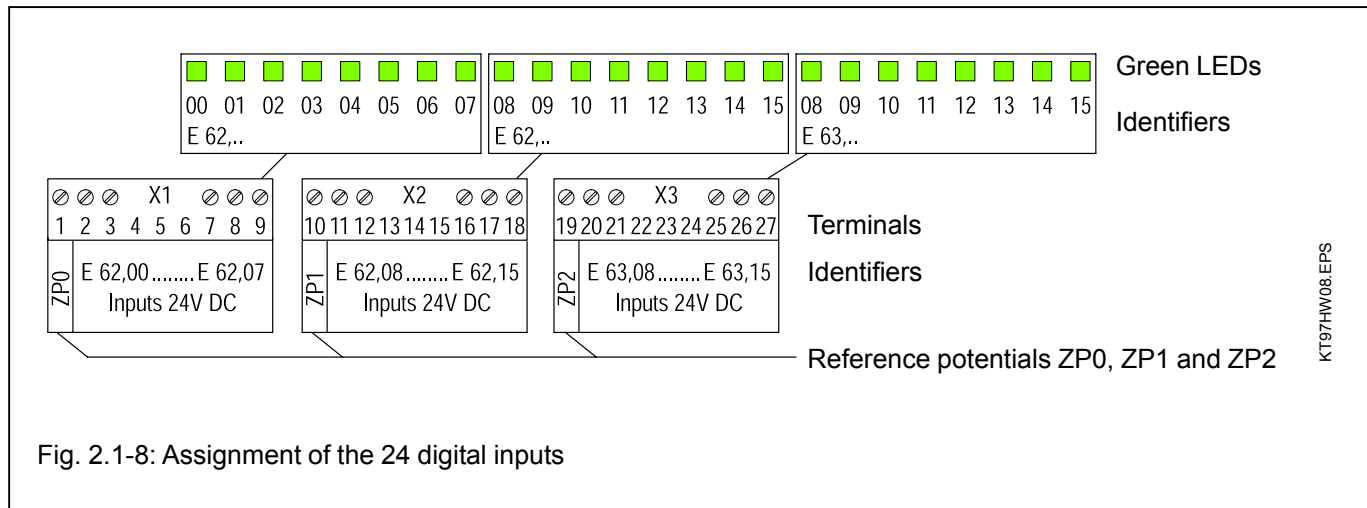

#### Features:

- The 24 digital inputs are arranged in three groups of 8 inputs each.
- The three groups E 62,00...E 62,07, E 62,08...E 62,15 and E 63,08...E 63,15 are electrically isolated from each other.
- The inputs use 24V signals in positive logic (1 = +24 V).
- The signal delay of the inputs is configurable to 7 ms (default) or 1 ms (see "System technology").
- The circuit configuration of the first group of the digital inputs is shown as an example in the following.

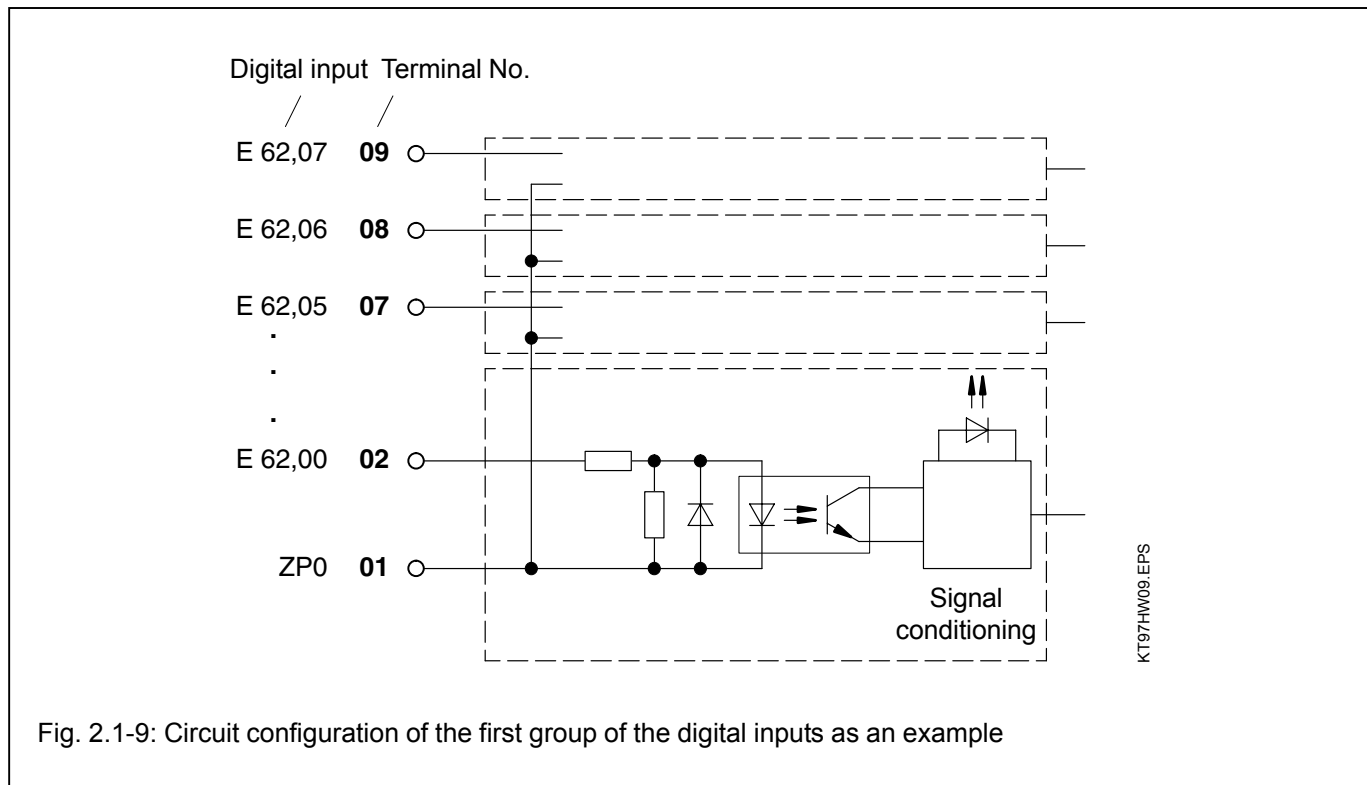

### 2.1.4.5 Connection of the digital outputs

The following figure shows the assignment of the 16 digital outputs.

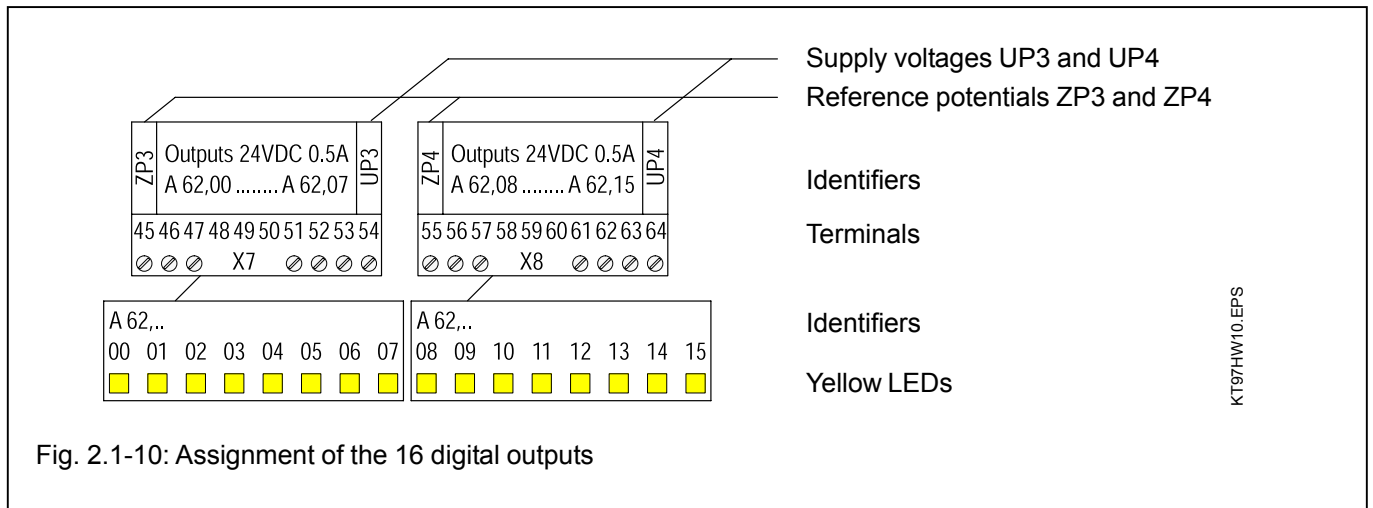

Fig. 2.1-10: Assignment of the 16 digital outputs

Features of the digital outputs:

- The 16 digital outputs are arranged in two groups of 8 outputs each.
- The two groups are electrically isolated from each other.
- The outputs can be loaded with a rated current of 500 mA.
- Each group as a whole is electrically isolated from the rest of the device.
- The outputs employ semiconductors and are short-circuit and overload-proof.
- The outputs are automatically switched off in case of overload or short-circuit.
- An overall error message indicates whether a short-circuit or an overload has occurred on a output group.
- The overload is displayed by the red LED Ovl. and via error flags in the PLC.
- The red LED Ovl. goes out when the overloaded output is switched on again automatically.
- The outputs are safe against reverse polarity and forced supply of 24 V DC.

## Circuit configuration of the digital outputs

The following figure shows the circuit configuration of the digital outputs of the first group as an example.

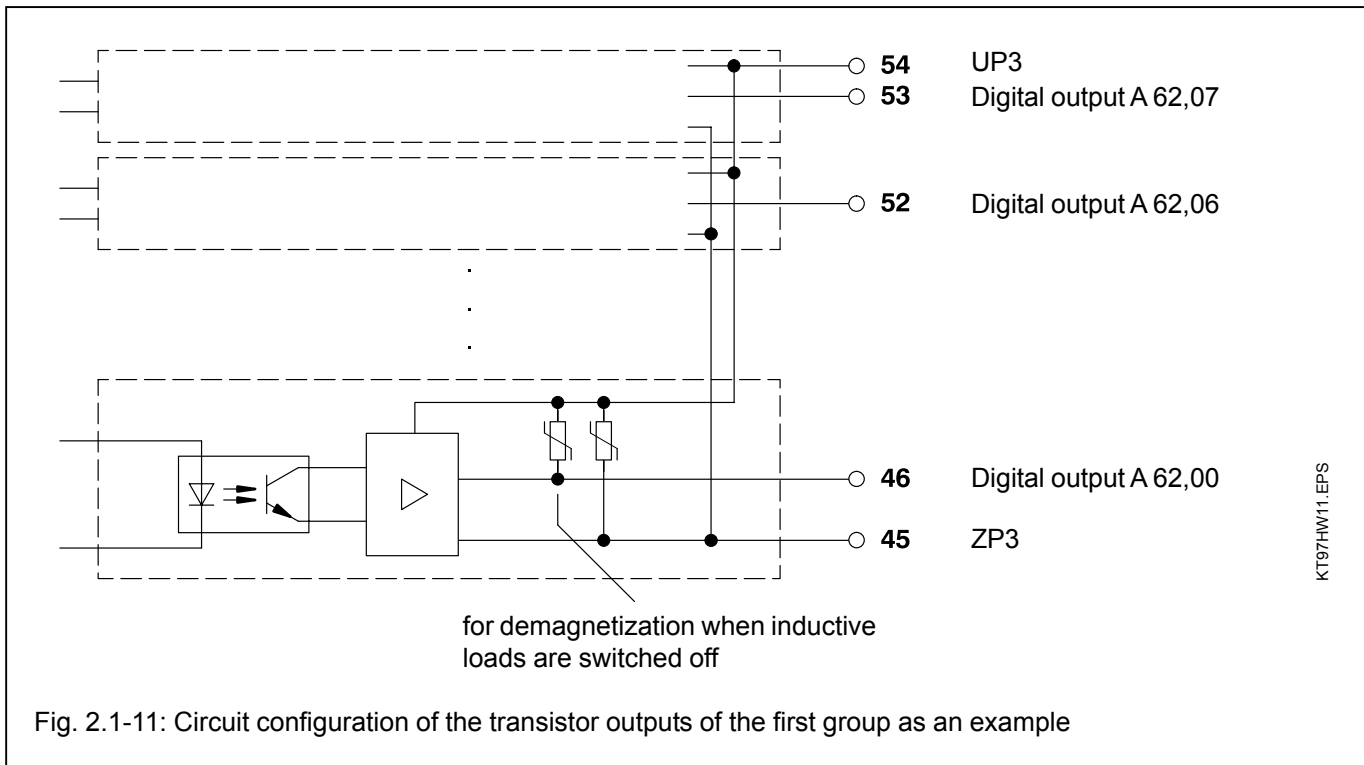

### 2.1.4.6 Connection of the digital inputs/outputs

The following figure shows the assignment of the 8 digital inputs/outputs.

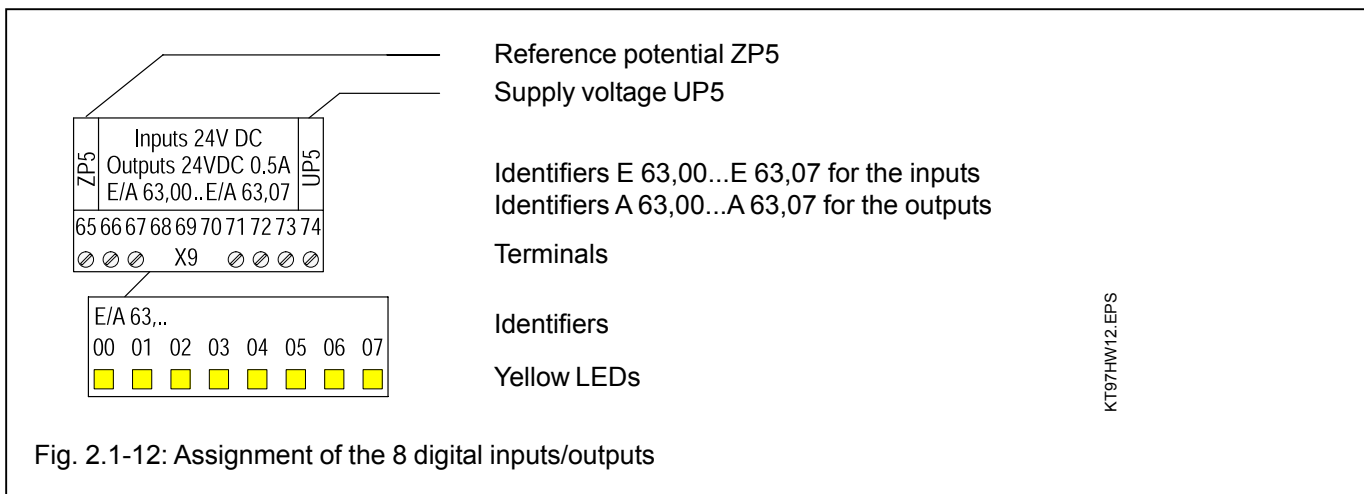

Features of the digital inputs/outputs:

- The 8 digital inputs/outputs are arranged in one group.
- The group as a whole is electrically isolated from the rest of the device.
- The inputs/outputs can be used individually as input, output or re-readable output.
- If the terminals are used as digital inputs, the input signal delay can be configured to 7 ms (default) or to 1 ms (see "System technology").
- If the terminals are used as digital outputs, the output signals "1" are individually monitored by the re-readable input. If the output status is wrong, an overall error message is generated for the involved output group. The error is displayed by the red LED Ovl. and by error flags of the PLC then. The error could have been caused by overload, short-circuit or missing supply voltage UP5/ZP5. The technical specifications of the outputs are the same as with the other digital outputs.



## Circuit configuration of the digital inputs/outputs

The following figure shows one of the 8 inputs/outputs of the group as an example.

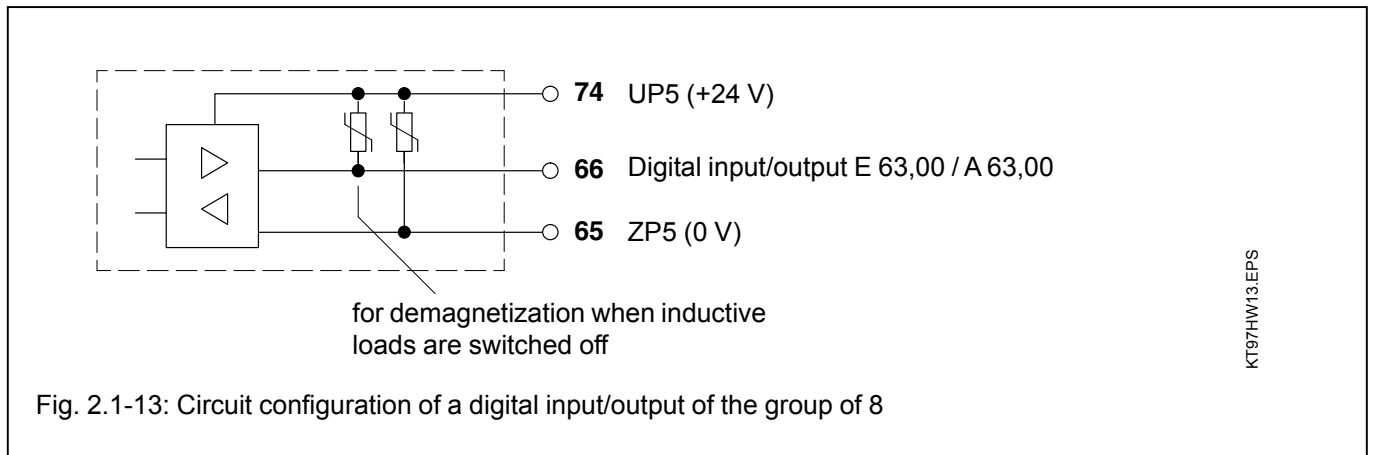

- The technical specifications of the inputs are the same with the other digital inputs, but **with the following exception:**

Caused by the direct electrical connection with the output, the varistor for demagnetization of inductive loads (see figure above) is also in effect at the input.

Therefore, the voltage difference between UP5 and the input signal must not be greater than the limit voltage of the varistor.

The limit voltage of the varistor is ca. 36 V. This means, that if UP5 = 24 V, the input signal voltage must be between -12 V and +30 V. If UP5 = 30 V, the input voltage has to be within -6 V and +30 V.

If all of the 8 channels of the group are used as inputs, and if in addition the UP5 terminal is left unconnected, no restrictions exist for the inputs. The input signal voltages then may be within -30 V and +30 V.

There is no restriction for the input/output group concerning its safety against reversed polarity.

### 2.1.4.7 Connection of the 8 configurable analog inputs

The following figure shows the assignment of the 8 analog inputs.

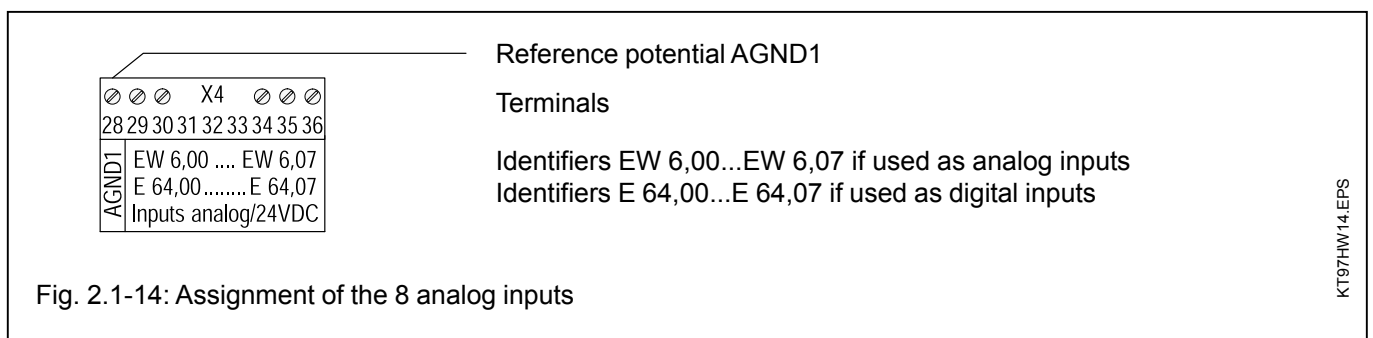

Features of the analog inputs:

- The 8 analog inputs are **not** electrically isolated.
- Resolution in the PLC system: The measured values are converted with a resolution of 12 bits, i.e. 11 bits plus sign for voltage and 12 bits without sign for currents. The ranges 0...5 V and  $\pm 5$  V are converted with 10 bits plus sign.
- Analog signals are conducted in shielded cables (see Fig. 2.1-5).

- The analog inputs can be used individually in a lot of different operating modes (even as digital inputs). The operating modes are configurable.

- In order to make sure, that unused input channels have a defined 0V level, they may be shorted to AGND.

In the following, some application examples are shown for analog sensors.

**Measuring ranges  $\pm 10\text{ V}$  /  $\pm 5\text{ V}$  /  $0\dots 10\text{ V}$  /  $0\dots 5\text{ V}$**

Input voltages which exceed the measuring range cause an overflow error message. If the measured value is below the range, an underflow error message is generated.

The input impedance is  $> 100\text{ k}\Omega$ .

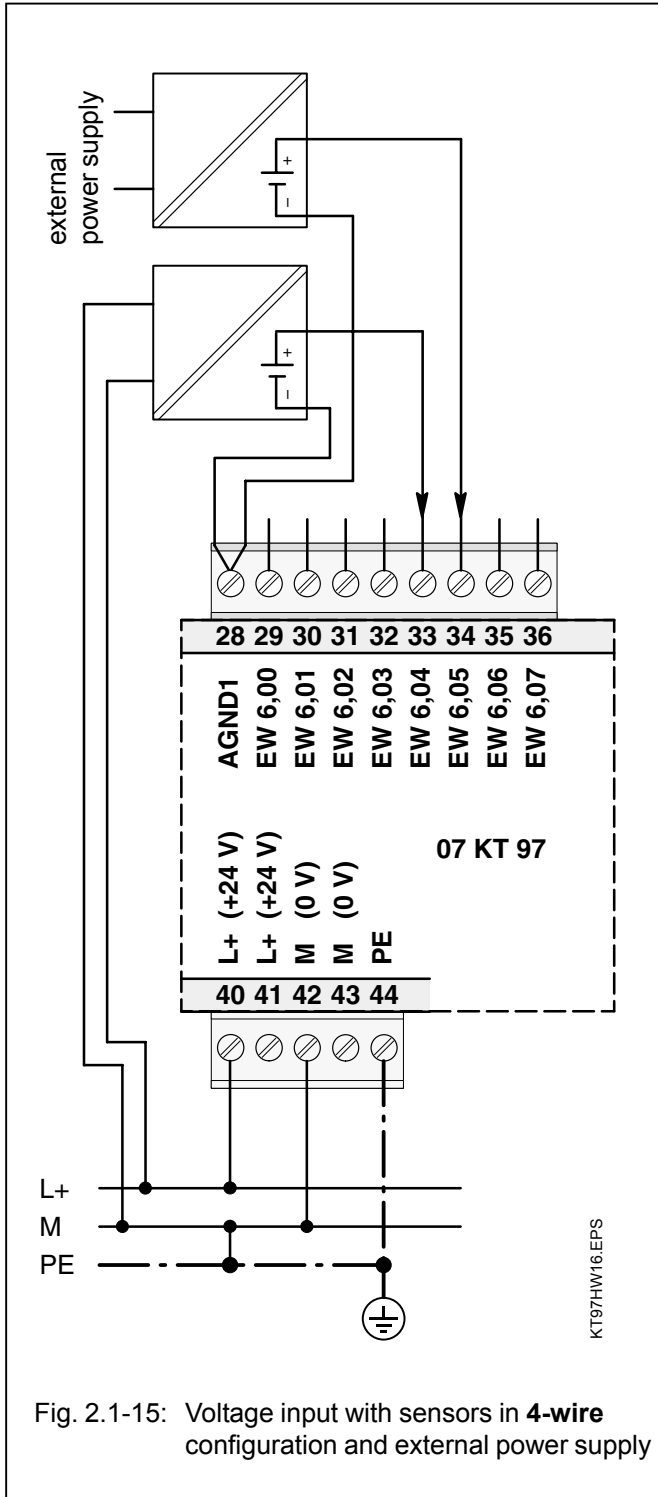

Fig. 2.1-15: Voltage input with sensors in **4-wire** configuration and external power supply

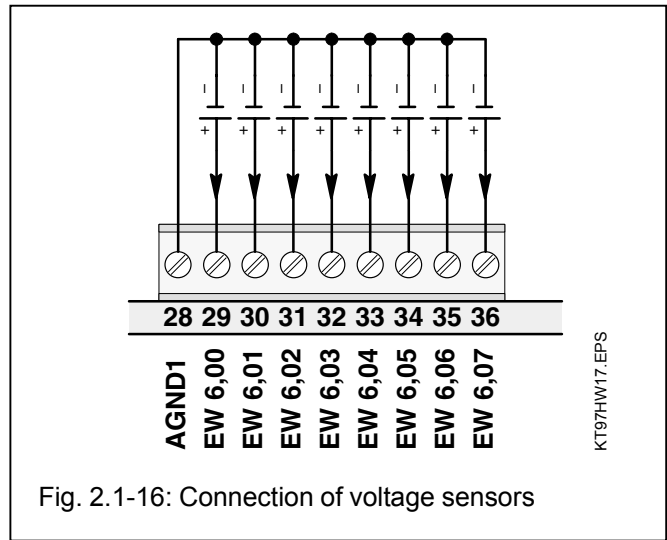

Fig. 2.1-16: Connection of voltage sensors

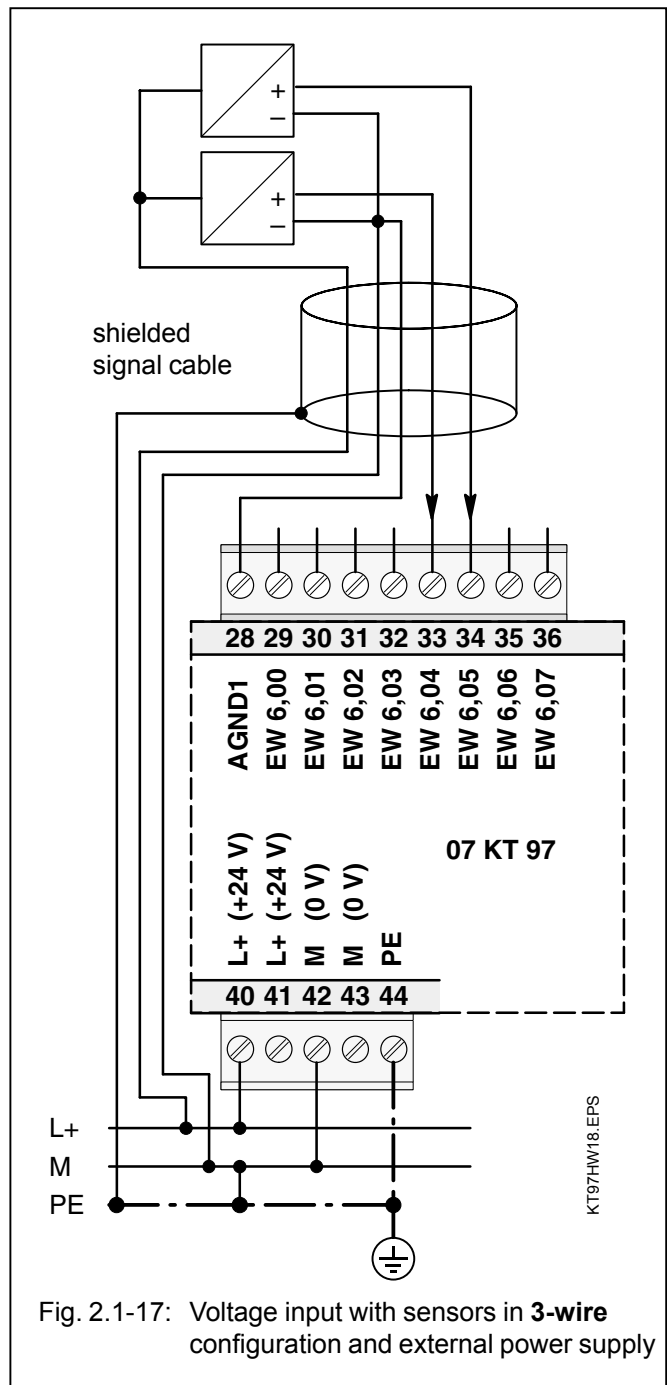

Fig. 2.1-17: Voltage input with sensors in **3-wire** configuration and external power supply

**Measuring range 4...20 mA  
(passive-type 2-pole sensors)**

Input currents which exceed the measuring range cause an overflow error message. If the measured value is below the range, an underflow error message is generated.

The input impedance is ca. 330 Ω. The current input has a self-protecting mechanism. If the input current gets too high, the shunt is switched off and the value for range overflow is generated. About every second, the unit tries to switch on the shunt again. In this way the correct measurement will succeed after the current has reached a normal value again.

The trigger of the self-protecting mechanism is displayed by the red LED Ovl. as long as the overload is present. In the PLC system an error message is then stored (FK4, error number 4).

The open-circuit monitoring begins below ca. 3 mA. The value of the range underflow is stored. If the open-circuit monitoring is configured, the open-circuit event is displayed by the red LED Ovl. as long as it is present. In the PLC system an error message is stored (FK4, error number 9).

The following figure shows the connection of **2-pole passive-type** analog sensors 4...20 mA.

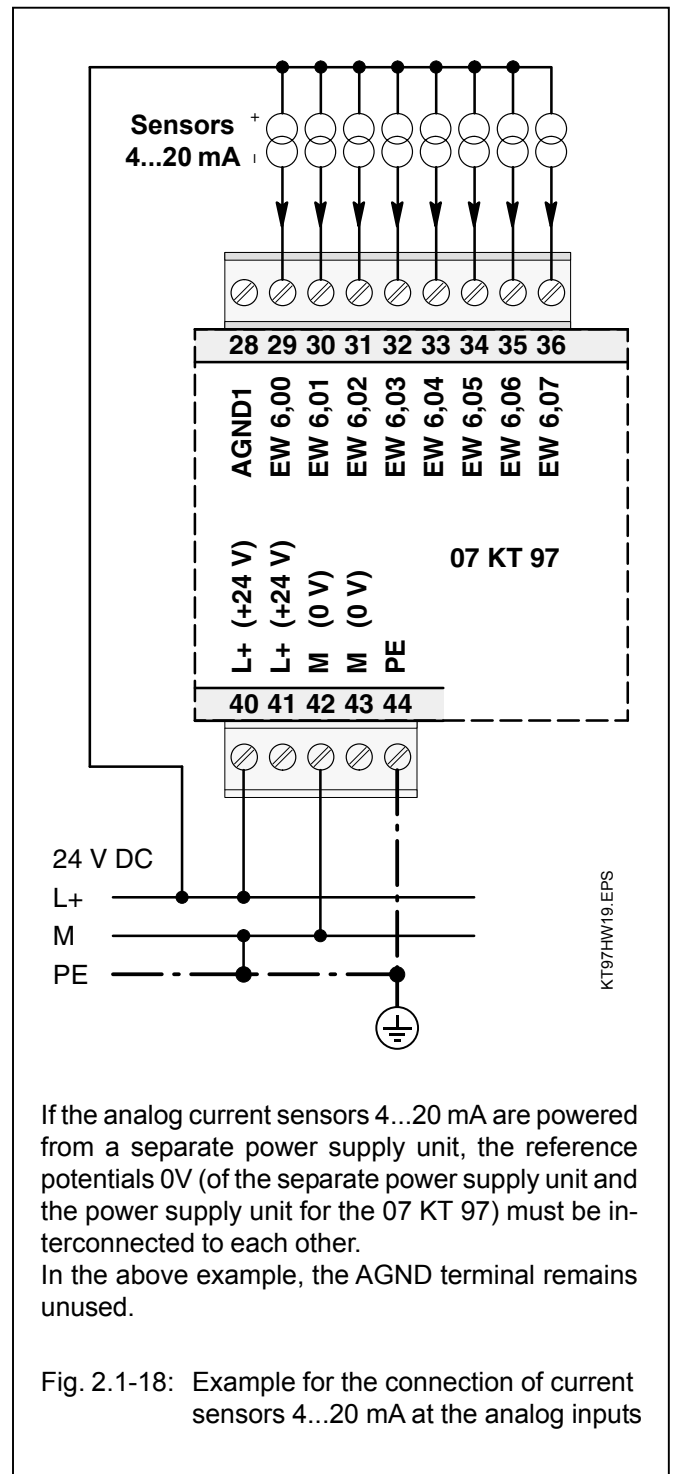

If the analog current sensors 4...20 mA are powered from a separate power supply unit, the reference potentials 0V (of the separate power supply unit and the power supply unit for the 07 KT 97) must be interconnected to each other. In the above example, the AGND terminal remains unused.

Fig. 2.1-18: Example for the connection of current sensors 4...20 mA at the analog inputs

**Measuring range 0...20 mA  
(active-type sensors with external supply voltage)**

Input currents which exceed the measuring range cause an overflow error message. If the measured value is below the range, an underflow error message is generated.

The input impedance is ca. 330 Ω. The current input has a self-protecting mechanism. If the input current gets too high, the shunt is switched off and the value for range overflow is generated. About every second, the unit tries to switch on the shunt again. In this way the correct measurement will succeed after the current has reached a normal value again.

The trigger of the self-protecting mechanism is displayed by the red LED Ovl as long as the overload is present. In the PLC system an error message is then stored (FK4, error number 4).

The following figure shows the connection of a 3-wire sensor powered by 24 V DC **and** of a 2-pole sensor powered electrically isolated. Both sensors work as **active current sources** 0...20 mA.

**It has to be taken into consideration, that in this application the M terminal of the basic unit is the reference potential. AGND1 is not dimensioned for carrying the sum of the sensor currents.**

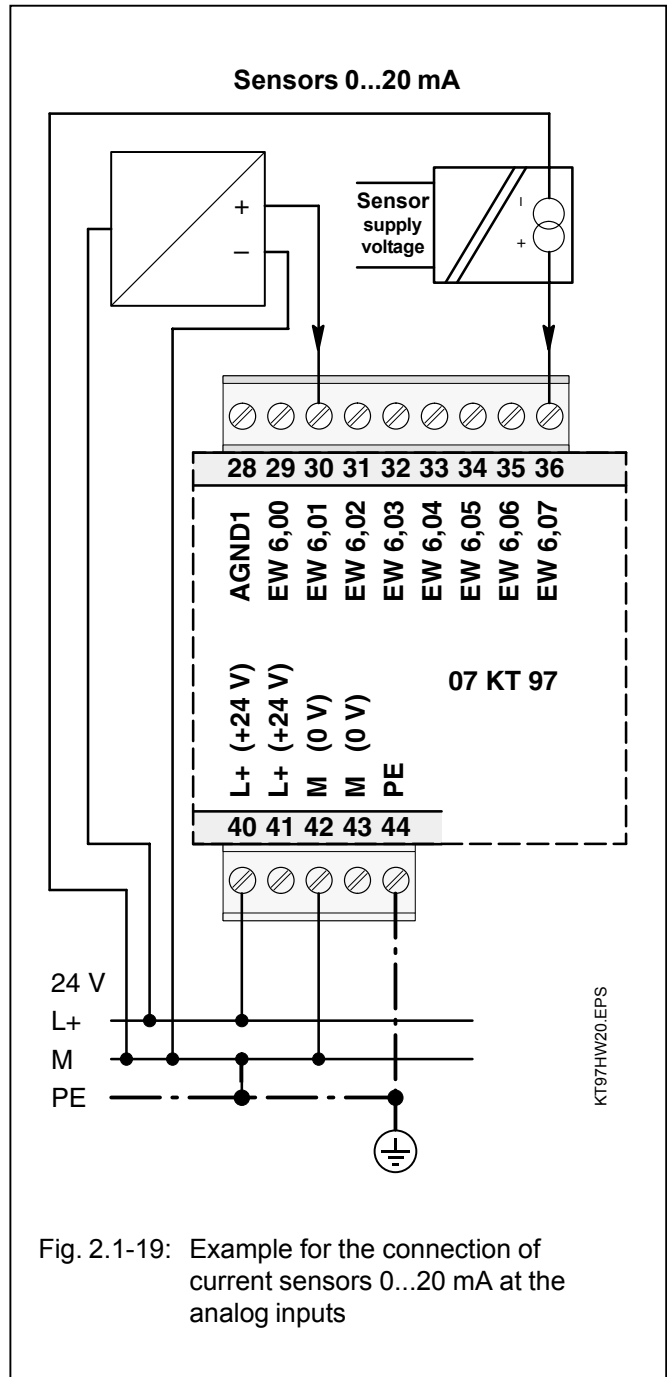

Fig. 2.1-19: Example for the connection of current sensors 0...20 mA at the analog inputs

**Measuring ranges  $\pm 10\text{ V}$  /  $\pm 5\text{ V}$  /  $0\text{...}10\text{ V}$  /  $0\text{...}5\text{ V}$  as differential inputs**

Differential inputs are very useful, if analog sensors are used which are remotely non-isolated (e.g. the minus terminal is remotely earthed).

Since the earthing potential is not exactly the same as AGND1, it has to be measured bipolar in order to compensate measuring errors. Additionally, in case of single-pole configuration, AGND1 would be connected directly to the remote earth potential. This would cause inadmissible (and possibly dangerous) earthing loops.

In all configurations using **differential inputs** two adjacent analog inputs belong together (e.g. EW 6,00 and EW 6,01).

The measured value is calculated by subtraction. The value of the channel with the lower address is subtracted from the value of the channel with the higher address.

The converted measured value is available on the odd address (e.g. EW 6,01).

**Important:**

The common mode input voltage range equals the measuring range of the single channel. I.e. that the signals, related to AGND, at the two involved inputs must not exceed this measuring range.

Input voltages which exceed the measuring range cause an overflow error message. If the measured value is below the range, an underflow error message is generated.

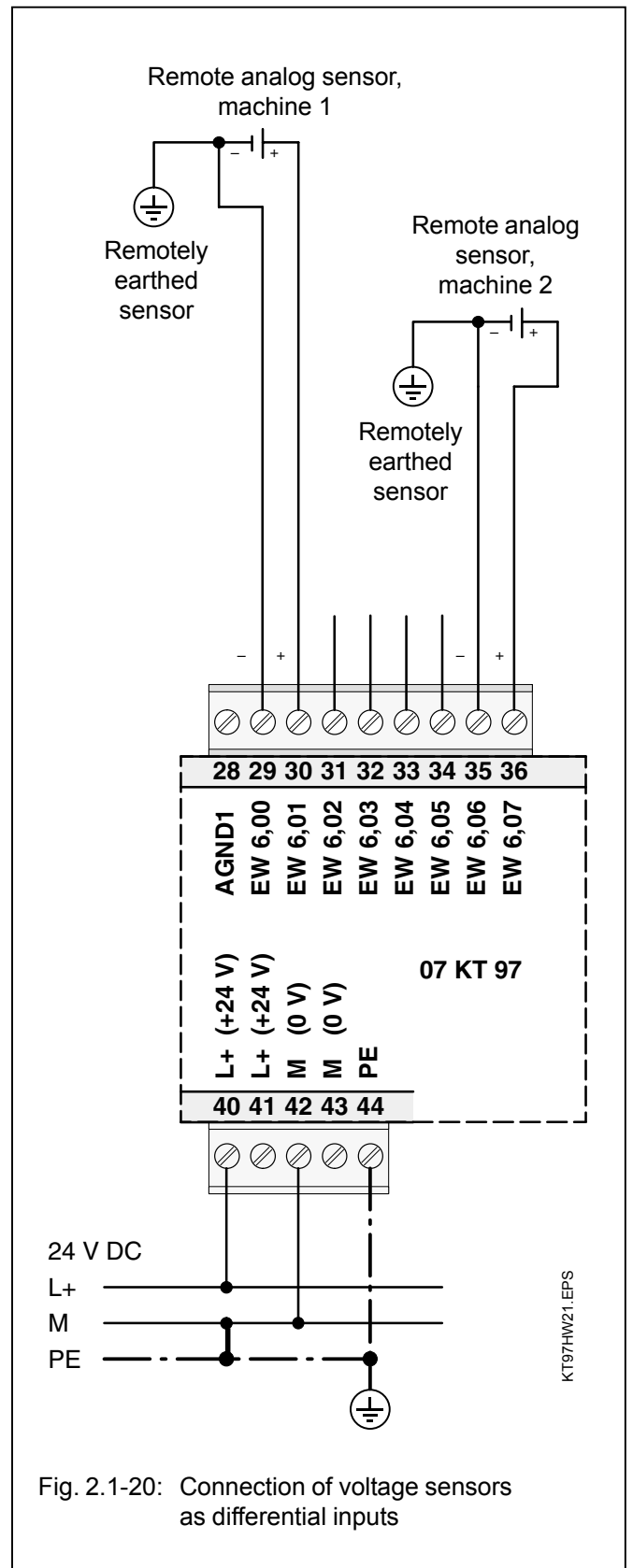

Fig. 2.1-20: Connection of voltage sensors as differential inputs

## Measuring ranges $-50^{\circ}\text{C} \dots +400^{\circ}\text{C}$ and $-50^{\circ}\text{C} \dots +70^{\circ}\text{C}$ with Pt100 as temperature sensor in 2-wire configuration

When resistance thermometers are used, a constant current must flow through the measuring resistor in order to create the necessary voltage drop for the evaluation. For this purpose, the basic unit 07 KT 97 provides a constant current sink, which is multiplexed to the 8 analog channels.

The following figure shows the connection of Pt100 resistance thermometers in **2-wire configuration**.

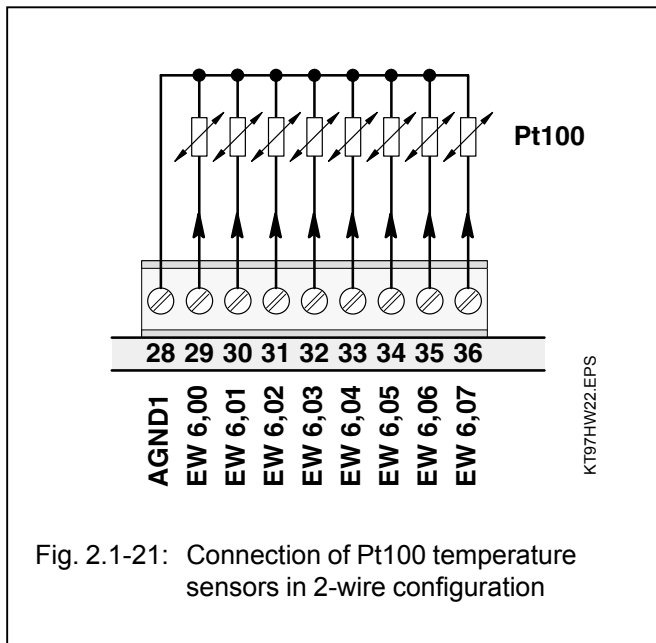

Fig. 2.1-21: Connection of Pt100 temperature sensors in 2-wire configuration

Depending on the configured operating mode, the measured value is assigned linearly as follows:

Range	assigned numerical value range
$-50^{\circ}\text{C} \dots 400^{\circ}\text{C}$	$-1022 \dots +8190$ (FC02 <sub>H</sub> ...1FFE <sub>H</sub> )
$-50^{\circ}\text{C} \dots 70^{\circ}\text{C}$	$-1022 \dots +1433$ (FC02 <sub>H</sub> ...0599 <sub>H</sub> )

The basic unit linearizes the Pt100 characteristic.

Temperatures which exceed the measuring range cause an overflow error message. If the measured value is below the range, an underflow error message is generated.

A detected open-circuit causes an overflow error message. If the sensor is short-circuited, an underflow error message is generated.

If the open-circuit or short-circuit monitoring is configured, the detected error is displayed by the red LED Ovl as long as it is present. In the PLC system an error message is stored (FK4, error number 9).

In order to avoid error messages with unused analog inputs, it is useful, **not** to configure this channels for Pt100.

## Measuring ranges $-50^{\circ}\text{C} \dots +400^{\circ}\text{C}$ and $-50^{\circ}\text{C} \dots +70^{\circ}\text{C}$ with Pt100 as temperature sensor in 3-wire configuration

The following figure shows the connection of Pt100 resistance thermometers in **3-wire configuration**.

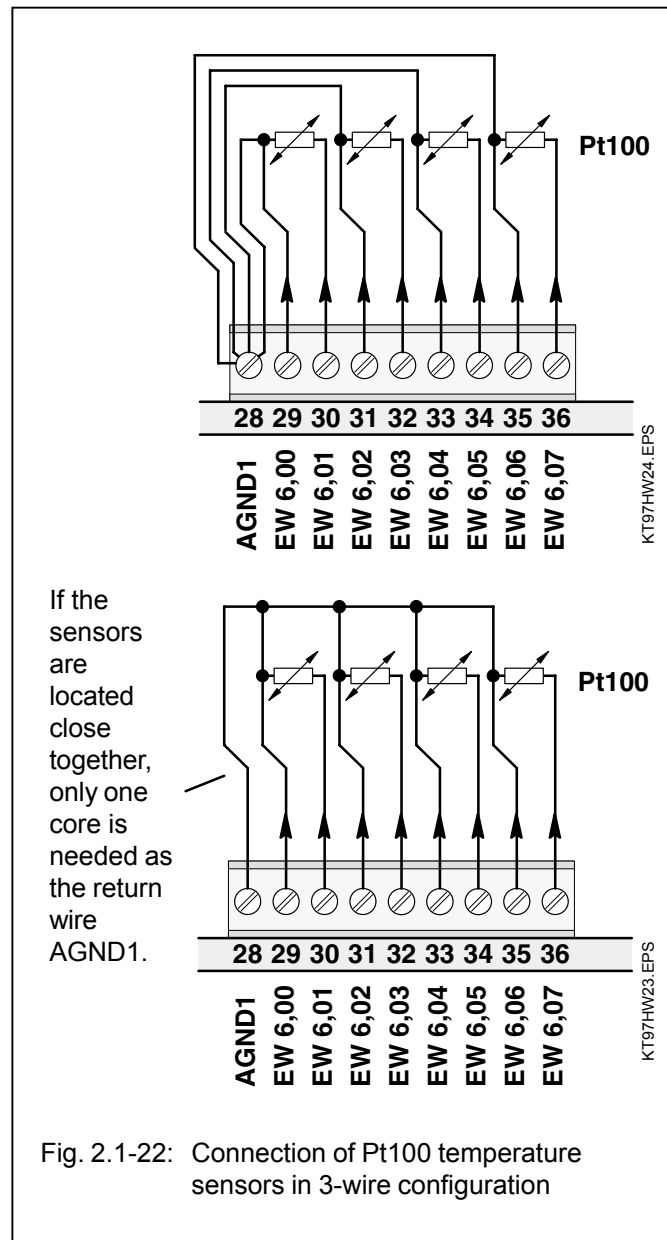

Fig. 2.1-22: Connection of Pt100 temperature sensors in 3-wire configuration

In the operating mode "**Pt100 in 3-wire configuration**" two adjacent analog inputs belong together (e.g. EW 6,00 and EW 6,01).

For configuration, both inputs must be configured to the desired operating mode.

The constant current of the one channel flows through the Pt100 resistance sensor, the constant current of the other channel through one of the wires.

The basic unit calculates the measuring value from the two voltage drops and stores it under the odd address (e.g. EW 6,01).

In order to avoid measurement errors, it is absolutely necessary, to lead the cores to the Pt100 sensors in the same cable. The cores must have the same cross section. Per channel, a twisted pair is used (for the two terminals of the Pt100 sensors) plus a single core (half of a twisted pair) for the connection to AGND1.

Depending on the configured operating mode, the measured value is assigned linearly as follows:

Range	assigned numerical value range
-50 C...400°C	-1022...+8190 (FC02 <sub>H</sub> ...1FFE <sub>H</sub> )
-50 C...70°C	-1022...+1433 (FC02 <sub>H</sub> ...0599 <sub>H</sub> )

The basic unit linearizes the Pt100 characteristic.

Temperatures which exceed the measuring range cause an overflow error message. If the measured value is below the range, an underflow error message is generated.

A detected open-circuit causes an overflow error message. If the sensor is short-circuited, an underflow error message is generated.

If the open-circuit or short-circuit monitoring is configured, the detected error is displayed by the red LED Ovl as long as it is present. In the PLC system an error message is stored (FK4, error number 9).

In order to avoid error messages with unused analog inputs, it is useful, **not** to configure this channels for Pt100.

### Use of analog inputs as digital inputs

Several (or all) analog inputs can be configured as digital inputs. When doing so, they evaluate input voltages higher than ca. +7 V as signal 1. The input impedance in this operating mode is about 4 kΩ. Terminal M is the reference potential.

The input signal delay is 7 ms. It cannot be configured. The inputs are not electrically isolated.

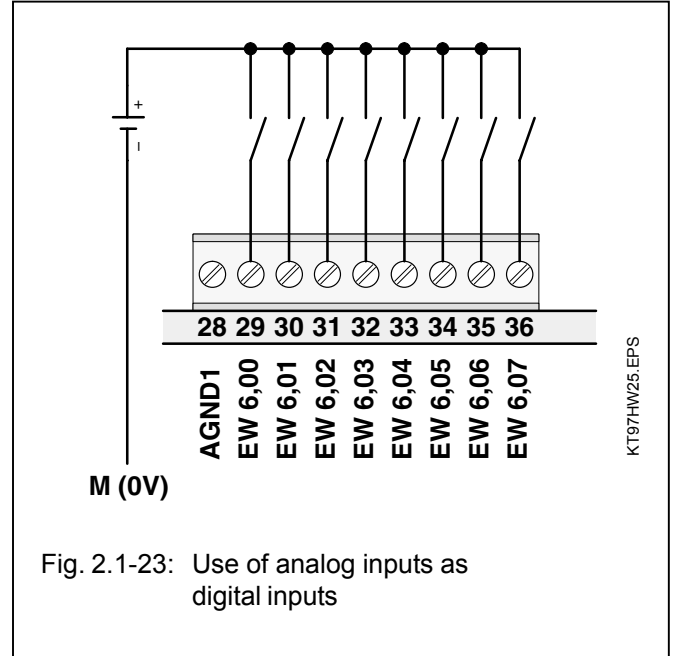
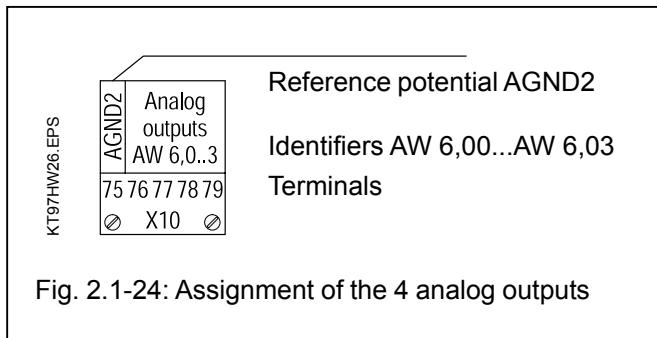

Fig. 2.1-23: Use of analog inputs as digital inputs

KT97HW25.EPS

### 2.1.4.8 Connection of the 4 configurable analog outputs

The following figure shows the assignment of the 4 configurable analog outputs.



Features of the analog outputs:

- The 4 analog outputs are **not** electrically isolated..
- Resolution in the control system:  
All analog output values are converted with a resolution of 12 bits, i.e either 11 bits plus sign or 12 bits without sign.
- Analog signals are conducted in shielded cables (see Fig. 2.1-5).
- The analog outputs can be used individually in a lot of different operating modes. The operating modes can be configured with system constants.
- Unused output channels may be left unconnected.

In the following, an application example for an analog receiver is shown.

#### Output ranges $\pm 10$ V / 0...20 mA / 4...20 mA

In case of voltage outputs the max. output current is  $\pm 3$  mA. The output is short-circuit proof.

In case of current outputs, the range of permissible output load resistors is 0...500  $\Omega$ . If in case of an error the outputs are switched off, this means the following:

Configuration  $\pm 10$  V      0 V  
 Configuration 0...20 mA    0 mA  
 Configuration 4...20 mA    0 mA.

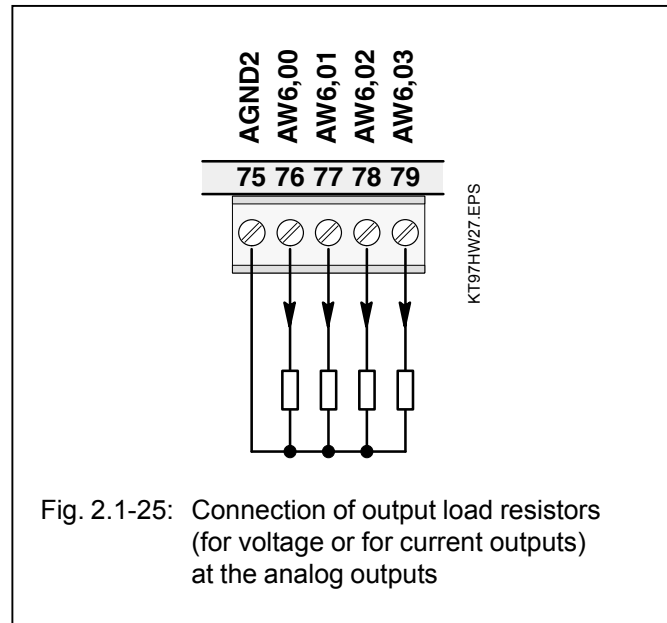

### Circuit configuration of an analog output

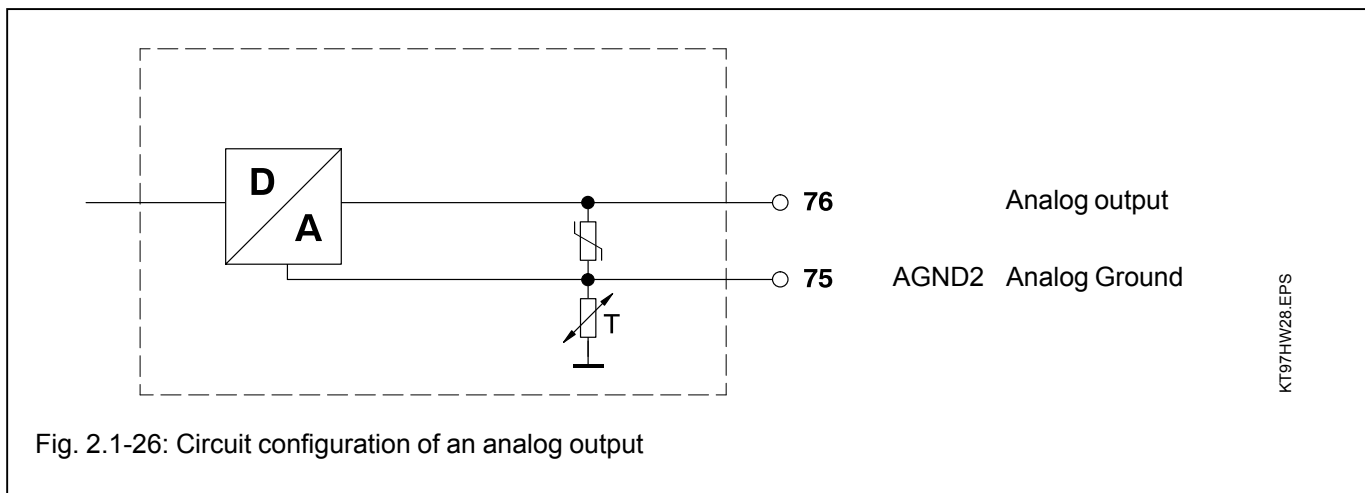



### 2.1.4.9 Battery and battery replacement

- The lithium battery 07 LE 90 can be inserted into the battery compartment in order to
  - backup data of user program in RAM
  - backup data of additionally in RAM contained information, e.g. flag statuses
  - backup of time and date

The battery lifetime is typ. 5 years at 25°C. The battery lifetime is the time during which the device remains operable in order to backup data while the supply voltage of the basic unit is switched off. As long as there is a supply voltage available, there is no more load on the battery other than its own leakage current.

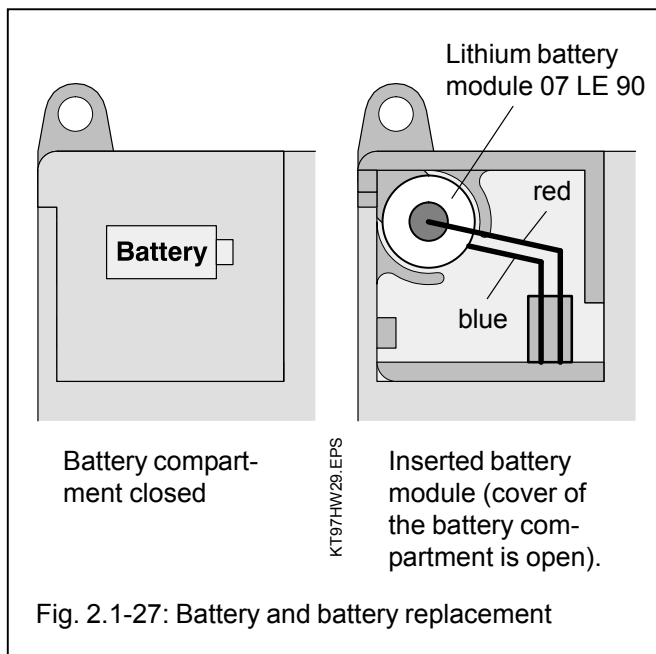

Fig. 2.1-27: Battery and battery replacement

The following handling notes have to be observed:

- Use only lithium batteries approved by ABB.
- Replace the battery by a new one at the end of its life.
- **Never short-circuit the battery!**  
There is danger of overheating and explosion. Avoid accidental short-circuits, therefore do not store batteries in metallic containers or boxes and do not bring them into contact with metallic surfaces.
- **Never try to charge a battery!**  
Danger of overheating and explosion.
- **Replace the battery only with the supply voltage switched on!**  
Otherwise you risk data being lost.
- **Dispose of battery environmentally consciously!**
- If no battery is inserted or if the battery is exhausted, the red LED "Battery" lights up.

### 2.1.4.10 Serial interface COM1

Interface standard: EIA RS-232

#### Assignment of the serial interface COM1

The serial interface COM1 has the following pin assignment:

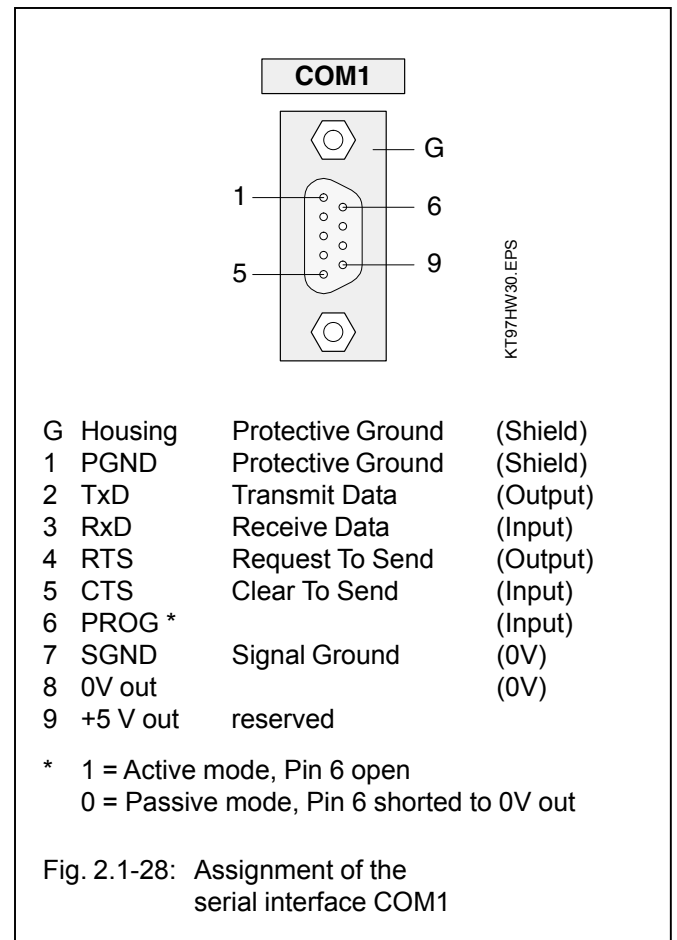

Fig. 2.1-28: Assignment of the serial interface COM1

### 2.1.4.11 Serial interface COM2

Interface standard: EIA RS-232

#### Assignment of the serial interface COM2

The serial interface COM2 has the following pin assignment:

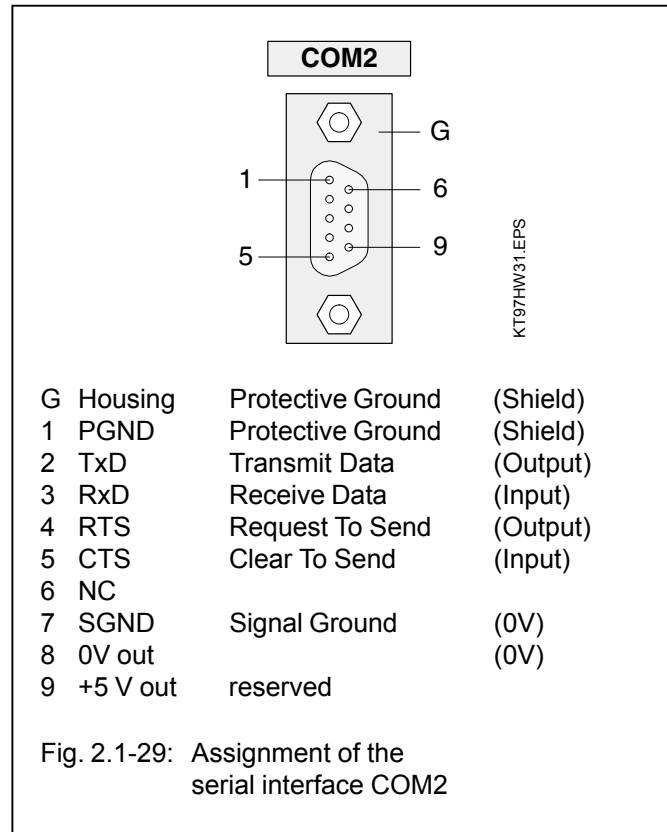

### 2.1.4.12 Networking interface

The 07 KT 97 basic unit is equipped with a special parallel interface. It is thus possible to network it with another bus system using an additional communication processor module.

The additional communication processor has its own housing. Both housings (of the 07 KT 97 and of the communication processor) are assembled by means of a snap-on connection.

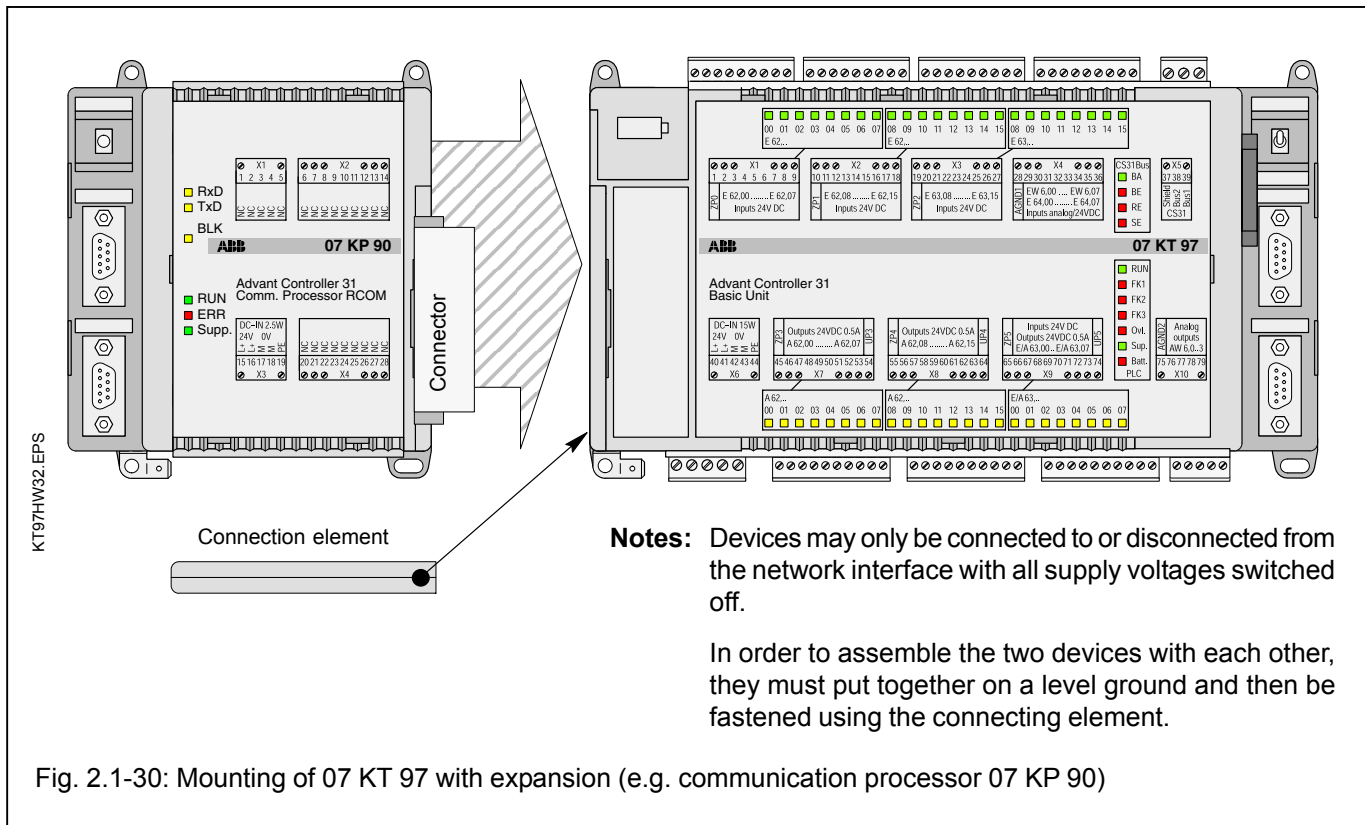

## 2.1.5 SmartMedia Card 07 MC 90

The SmartMedia Card serves for storing data up to 2 MB or 8 MB not being lost over an power OFF/ON cycle. It is used in the 07 KT 95...98 and 07 SL 97 basic units. It is recommended only to use ABB-proven SmartMedia Cards.

### Field of application

- Storing and loading of PLC programs
- Storing and loading of user data
- Loading of firmware updates

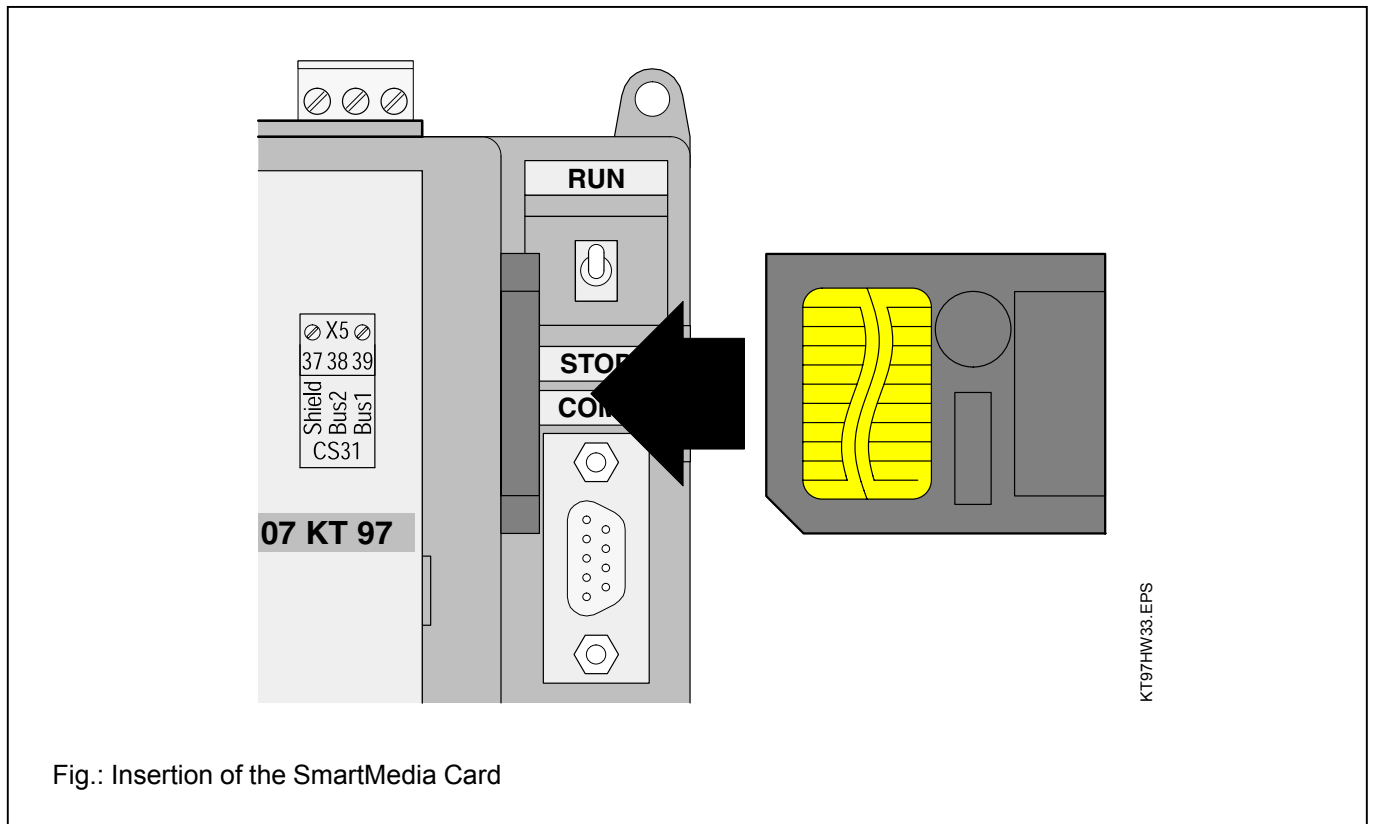

### Handling instructions

- The SmartMedia Card is inserted with the contact field visible (see the figure above).
- A SmartMedia Card, once initialized as user data memory, can no more be used as a user program card.
- The SmartMedia Card must be protected from
  - mechanical stress (e.g. do not bend)
  - electrostatic discharge
  - contact pollution (do not touch the contacts)

### Important note

SmartMedia Cards with a supply voltage of 3.3 V cannot be used with basic units of the versions R01xx. They also cannot be used with 07 SL 97 basic units (see Usability).

### Access

- Access within the PLC program is possible with function blocks, see documentation of the programming software.

### Usability

SmartMedia Card 07 MC 90 **5 V** GJR5 2526 00 **R0101** (supply voltage 5 V, usable with the basic units 07 SL 97, 07 KT 95 to 07 KT 98 **R 01xx** and **R02xx**, all firmware versions, memory capacity 2 MB)

SmartMedia Card 07 MC 90 **3,3 V** GJR5 2526 00 **R0201** (supply voltage 3.3 V, usable with the basic units 07 KT 95 to 07 KT 98 **R02xx** with firmware versions as of V5.0, memory capacity 8 MB)

### Technical data

Weight	2 g
Dimensions	45 x 37 x 0.7 mm

### Order numbers

07 MC 90	5 V	2 MB	GJR5 2526 00 <b>R0101</b>
07 MC 90	3.3 V	8 MB	GJR5 2526 00 <b>R0201</b>

## 2.1.6 High-speed counter

### Features

The high-speed counter used in the basic unit 07 KT 97 works independently of the user program and is therefore able to respond quickly to external signals. It can be used in seven different and configurable operating modes.

The desired operating mode is set in a system constant (see documentation part "System technology"). The configured operating mode is only activated during initialization (power-on, cold start, warm start). For all operating modes, the same function block **COUNTW** is used (see programming software).

Independent of the selected operating mode, the following features are valid:

- The pulses at the counter input or the evaluated signals at tracks A and B in case of connection of incremental position sensors are counted.
- The maximum counting frequency is 50 kHz.
- The counter uses the terminals 2 (E 62,00) and 3 (E 62,01) as fast inputs and, in one operating mode, also the output terminal 46 (A 62,00). In order to make all binary inputs and outputs available for other purposes than counting, it is possible, to disable the 07 KT 97's counting function.
- The counter can count upwards in all operating modes, in some modes it also can count downwards. The counting range is from  $-32768$  to  $+32767$  or from  $8000_H$  to  $7FFF_H$ .

## 2.1.7 Technical Data 07 KT 97

In general, the technical system data listed under "System data and system configuration" in chapter 1 of volume 2 of the Advant Controller 31 system description are valid. Additional data or data which are different from the system data are listed as follows.

### 2.1.7.1 General data

Number of digital inputs	24
Number of digital transistor outputs	16
Number of digital inputs/outputs	8
Number of analog inputs	8
Number of analog outputs	4
I/O expansion via CS31 system bus by up to	992 digital inputs 992 digital outputs 224 analog input channels 224 analog output channels max. 31 remote modules altogether
Number of serial interfaces	2 (for programming or connection to man-machine communication)
Number of parallel interfaces	1 special interface for connection of a communication processor (for networking with other bus systems)
Integrated memory	Flash EPROM 512 kB (480 kB program + configuration data) RAM 2 MB (480 kB program with on-line programming + 256 kB variables)
Resolution of the integrated real-time clock	1 second
Data of the integrated high-speed hardware counter	
Number of operating modes	7
Counting range	-32768...+32767 (16 bits signed integer)
Counting frequency	max. 50 kHz
Processing time, 65 % bits, 35 % words	typ. 0.3 ms/kB program
Number of software timers	any (max. 80 simultaneously active)
delay time of the timers	1 ms...24.8 days
Number of up/down counter software blocks	any
Number of bit flags           in the addressable flag area	8192
Number of word flags           "	8192
Number of double word flags   "	1024
Number of step chains           "	256
Number of constants KW         "	1440
Number of constants KD         "	384
Indication of operating statuses and errors	60 LEDs altogether
Wiring method	removable screw-type terminal blocks
Power supply, CS31 system bus	max. 1 x 2.5 mm <sup>2</sup> or max. 2 x 1.5 mm <sup>2</sup> (see also page 2.1-9)
all other terminals	max. 1 x 1.5 mm <sup>2</sup>
<b>2.1.7.2 Power supply</b>	
Rated supply voltage	24 V DC
Current consumption	max. 0.35 A
Protection against reversed polarity	yes

### 2.1.7.3 Lithium battery

Battery for backup of RAM contents

Battery module 07 LE 90

Lifetime at 25°C

typ. 5 years

### 2.1.7.4 Digital inputs

Number of channels per module

24

Distribution of channels into groups

3 groups of 8 channels each

Common reference potential

for group 1 (8 channels)

ZP0 (channels 62,00...62,07)

for group 2 (8 channels)

ZP1 (channels 62,08...62,15)

for group 3 (8 channels)

ZP2 (channels 63,08...63,15)

Electrical isolation

between the groups,  
between groups and other circuitry  
(see also Fig. 2.1–4)

Signal coupling of input signals

with optocoupler

Configuration possibilities of the inputs

Input signal delay

typ. 7 ms (configurable to 1 ms)

Channels E 62,00 and 62,01

configurable for the high-speed counter

Signalling of input statuses

one green LED per channel,  
the LEDs correspond functionally to the input signals

Input signal voltage

Signal 0

-30 V...+ 5 V

Signal 1

+13 V...+ 30 V

Input current per channel

Input voltage = +24 V

typ. 7.0 mA

Input voltage = + 5 V

> 0.2 mA

Input voltage = +13 V

> 2.0 mA

Input voltage = +30 V

< 9.0 mA

Max. cable length, unshielded

600 m

Max. cable length, shielded

1000 m

### 2.1.7.5 Digital outputs

Number of channels per module

16 transistor outputs

Distribution of channels into groups

2 groups of 8 channels each

Common supply voltage

for group 1

UP3 (channels 62,00...62,07)

for group 2

UP4 (channels 62,08...62,15)

Electrical isolation

between the groups,  
between groups and other circuitry  
(see also Fig. 2.1–4)

Signalling of output statuses

one yellow LED per channel,  
the LEDs correspond functionally to the output signals

Output current

Rated value

500 mA with UP3/4 = 24 V

Maximum value

625 mA with UP3/4 = 24 V + 25%

Leakage current with signal 0

< 0.5 mA

Demagnetization of inductive loads

internally with a varistor

Switching frequency with inductive loads

max. 0.5 Hz

Switching frequency with lamp loads

max. 11 Hz with max. 5 W

Max. cable length		400 m (pay attention to voltage drops)
Short-circuit proof / overload proof		yes
Protection of the outputs against reversed polarity		yes
Forcing of 24 V DC at the outputs possible		yes
Total load (via UP3 or UP4)		max. 4 A
<b>2.1.7.6 Digital inputs/outputs</b>		
Number of channels per module		8 inputs/outputs
Distribution of channels into groups		1 group with 8 channels
Common reference potential		ZP5 (channels E/A 63,00...E/A 63,07)
Common voltage supply		UP5 (channels E/A 63,00...E/A 63,07)
Electrical isolation		between the group and other circuitry (see Fig. 2.1-4)
Signal coupling of the input signals		with optocoupler
Configuration possibilities of the inputs		
Input signal delay, channels E 63,00...E 63,07		typ. 7 ms (configurable to 1 ms)
Signalling of input/output statuses		one yellow LED per channel, the LEDs correspond functionally to the I/O signals
Input signal voltage (if used as inputs)		for details see Fig. 2.1-13 as well as the chapter "Circuit configuration of the digital inputs/outputs"
Signal 0		-6 V...+ 5 V
Signal 1		+13 V...+ 30 V
Input current per channel		see Digital inputs
Output current / switching frequency / inductive loads		see Digital outputs
Max. cable length		see Digital inputs/outputs
<b>2.1.7.7 Analog inputs</b>		
Number of channels per module		8
Distribution of channels into groups		1 group with 8 channels
Common reference potential		
for group 1 (8 channels)		AGND1 (channels 06,00...06,07)
Electrical isolation		none (see also Fig. 2.1-4).
Max. permissible potential difference between		
Terminal M (minus pole of the power supply voltage)		
and terminal AGND (analog I/O minus pole)		± 1 V
Signalling of input statuses		none
Configuration possibilities (each channel), see 2.1.4.7		0...10 V, 0...5 V, ±10 V, ±5 V (also with differential signal) 0...20 mA, 4...20 mA Pt100 -50...+400°C and -50...+70°C (2-wire and 3-wire configuration) digital input
Input impedance per channel,	voltage input	> 100 kΩ
	current input	ca. 330 Ω
	digital input	ca. 4 kΩ

The current input has a self-protecting mechanism. If the input current gets too high, the shunt is switched off and the value for range overflow is generated. About every second, the unit tries to switch on the shunt again. In this way the correct measurement will succeed after the current has reached a normal value again.

Time constant of the input filter	470 $\mu$ s with voltage, 100 $\mu$ s with current
Conversion cycle of current and voltage channels	Each configured input channel (U, I, Pt100) increases the conversion cycle of the U/I channels by typ. 1 ms.
Conversion cycle (by filtering time) of Pt100 channels	Each configured input channel (U, I, Pt100) increases the conversion cycle of the Pt100 channels by typ. 50 ms.
Conversion cycle of unused input channels	Input channels configured as "unused" are skipped, i.e. they do not need any conversion time.

#### Examples for the conversion cycle

Example No.	1	2	3	4	5	6
Channels configured for U/I	1	8 *	-	-	2	4
Channels configured for Pt100	-	-	4	8	2	4
Channels configured as "unused"	7	-	4	-	4	-
Conversion cycle of U/I channels	1 ms	8 ms	-	-	4 ms	8 ms
Conversion cycle of Pt100 channels	-	-	200 ms	400 ms	200 ms	400 ms

#### \* Factory setting

Resolution in bits	ranges $\pm 10$ V, 0...10 V ranges $\pm 5$ V, 0...5 V ranges 0...20 mA, 4...20 mA range -50 $^{\circ}$ C...+70 $^{\circ}$ C range -50 $^{\circ}$ C...+400 $^{\circ}$ C	11 bits plus sign 10 bits plus sign 12 bits without sign 10 bits plus sign 11 bits plus sign
Resolution in mV, $\mu$ A	range $\pm 10$ V range 0...10 V range 0...20 mA range 4...20 mA	ca. 5 mV ca. 5 mV ca. 5 $\mu$ A ca. 4 $\mu$ A
Relationship between input signal and hex code		$-100\% \dots 0 \dots +100\% = 8008_{\text{H}} \dots 0000_{\text{H}} \dots 7\text{FF}8_{\text{H}}$ (-32760...0...32760 decimal)
Conversion inaccuracy caused by non-linearity, temperature sensitivity, ageing, adjustment error on delivery and resolution:	U, I Pt100	typ. 0.5 %, max. 1 % typ. 1 $^{\circ}$ C, max. 2 $^{\circ}$ C
Threshold, if analog input is configured as digital input		ca. 7 V
Max. cable length, 2-core shielded and cross section $\geq 0,5$ mm <sup>2</sup>		100 m
<b>2.1.7.8 Analog outputs</b>		
Number of channels per module		4
Reference potential		AGND2 (channels 06,00...06,03)
Electrical isolation		none (see also Fig. 2.1-4).
Max. permissible potential difference between Terminal M (minus pole of the power supply voltage) and terminal AGND (analog I/O minus pole)		$\pm 1$ V



Signalling of output statuses	none
Output signal ranges (configurable)	-10 V...0...+10 V 0...20 mA 4...20 mA
Output load capability of the voltage outputs	max. ±3 mA
Resolution	12 bits
Resolution (1 LSB), range -10 V...0...+10 V	5 mV
Relationship between output signal and hex code	-100 %...0...+100 % = 8008 <sub>H</sub> ...0000 <sub>H</sub> ...7FF8 <sub>H</sub> (-32760...0...32760 decimal)
Conversion cycle for outputs	typ. 1 ms for each configured output channel
Conversion inaccuracy caused by non-linearity, temperature sensitivity, ageing, adjustment error on delivery and resolution	typ. 0.5 %, max. 1 %
Max. cable length, 2-core shielded and cross section ≥ 0,5 mm <sup>2</sup>	100 m

#### 2.1.7.9 Connection of serial interfaces COM1 and COM2

Interface standard	EIA RS-232
Programming with 907 AC 1131	with IBM PC (or compatible)
Program modifications with 907 AC 1131	with IBM PC (or compatible)
Man-machine communication	yes, e.g. with an operating station
Electrical isolation	versus digital inputs and outputs, versus CS31 system bus interface (see also Fig. 2.1-4)
Potential differences	In order to avoid potential differences between the 07 KT 97 basic unit and the peripheral devices con- nected to the COM1/COM2 interfaces, these devices are supplied from the switch-gear cabinet socket (see also the earthing connections in Fig. 2.1-5).
Pin configuration and description of the COM1/COM2 interfaces	see chapters 2.1.4.10 and 2.1.4.11

#### 2.1.7.10 Connection to the CS31 system bus

Interface standard	EIA RS-485
Connection as a Master PLC as a Slave PLC	yes, transmitting and receiving areas are configurable yes, see "System constants"
Setting of the CS31 module address	yes, by system constant, stored in Flash EPROM of the Slave PLC
Electrical isolation	versus supply voltage, inputs and outputs, versus interfaces COM1/COM2 (see also Fig. 2.1-4)
Terminal assignment and description of the CS31 bus interface	see chapter 2.1.4.3

### 2.1.7.11 LED displays

LEDs for indication of:

– Statuses of digital inputs	1 green LED per channel
– Statuses of digital outputs	1 yellow LED per channel
– Statuses of digital inputs/outputs	1 yellow LED per channel
– Power supply on	1 green LED
– Battery	1 red LED
– Program is running (RUN)	1 green LED
– Error classes (FK1, FK2, FK3)	1 red LED per error class
– CS31 system bus is running (BA)	1 green LED
– bus-specific errors (BE, RE, SE)	3 red LEDs
– Overload/short-circuit of digital outputs	1 red LED

### 2.1.7.12 High-speed hardware counter

Data of the integrated high-speed hardware counter:

Configurable	in 7 operating modes
Counting range	-32768...+32767 (16 bits)
Counting frequency	max. 50 kHz
Used inputs	E 62,00 and E 62,01
Used outputs	A 62,00

### 2.1.7.13 Mechanical data

Mounting on DIN rail	according to DIN EN 50022–35, 15 mm deep. The DIN rail is located in the middle between the upper and the lower edge of the module.
Fastening by screws	with 4 screws M4.
Width x height x depth	240 x 140 x 85 mm
Wiring method	by removable terminal blocks with screw-type terminals
Power supply terminals, CS31 system bus	max. 1 x 2.5 mm <sup>2</sup> or max. 2 x 1.5 mm <sup>2</sup>
All other terminals	max. 1 x 1.5 mm <sup>2</sup>
Weight	1.6 kg
Dimensions for mounting	see the following drawing

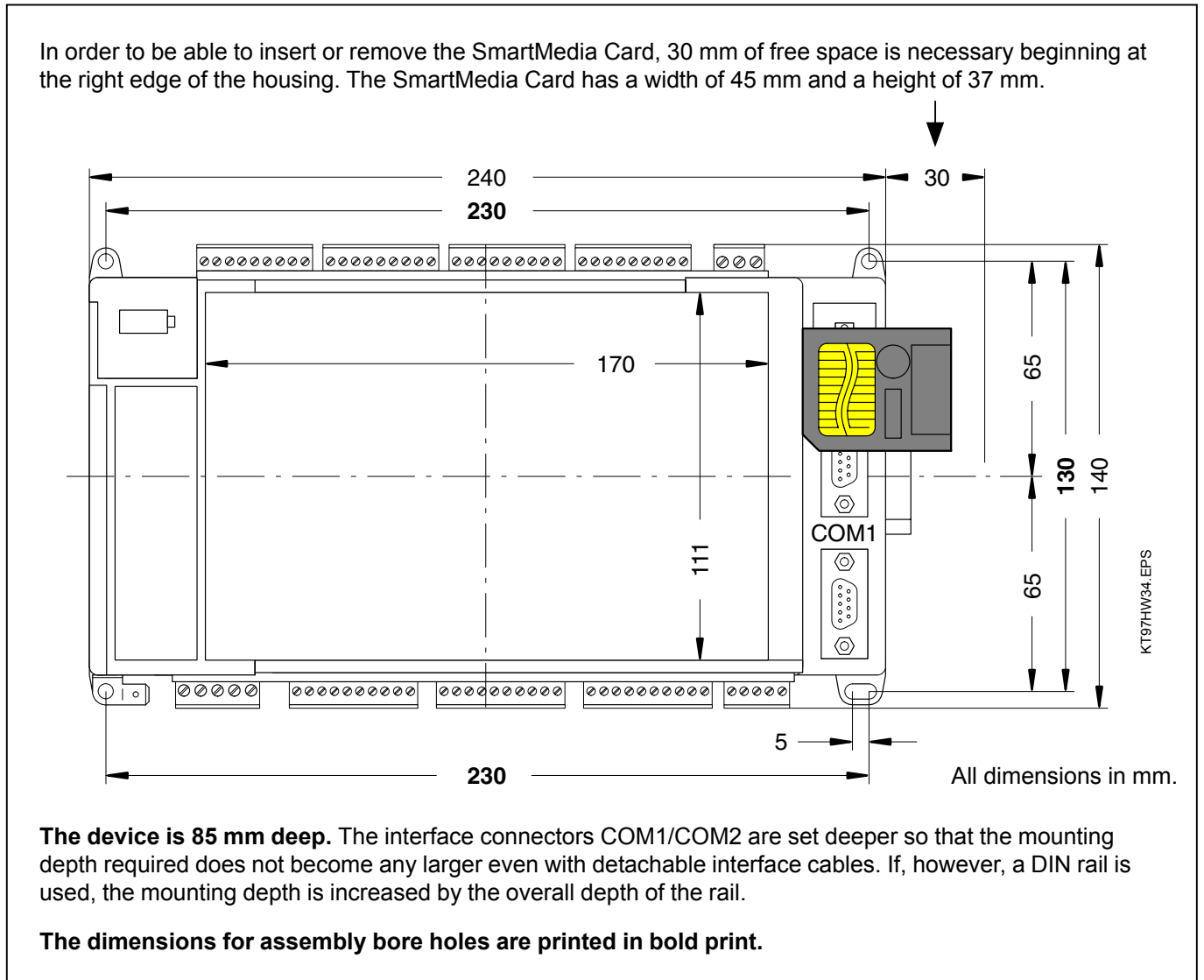

### 2.1.7.14 Mounting hints

Mounting position	vertical, terminals above and below
Cooling	The natural convection cooling must not be hindered by cable ducts or other material mounted in the switch-gear cabinet.

### 2.1.7.15 Ordering data

Basic unit 07 KT <b>97</b> R0100	Order No. GJR5 2530 00 R0100
Basic unit 07 KT <b>97</b> R0200	Order No. GJR5 2530 00 R0200
Basic unit 07 KT <b>97</b> R0120 (+ PROFIBUS-DP)	Order No. GJR5 2530 00 R0120
Basic unit 07 KT <b>97</b> R0220 (+ PROFIBUS-DP)	Order No. GJR5 2530 00 R0220
Basic unit 07 KT <b>97</b> R0160 (+ ARCNET)	Order No. GJR5 2530 00 R0160
Basic unit 07 KT <b>97</b> R0260 (+ ARCNET)	Order No. GJR5 2530 00 R0260
Basic unit 07 KT <b>97</b> R0162 (+ ARCNET + PROFIBUS-DP)	Order No. GJR5 2530 00 R0162
Basic unit 07 KT <b>97</b> R0262 (+ ARCNET + PROFIBUS-DP)	Order No. GJR5 2530 00 R0262
Basic unit 07 KT <b>97</b> R0270 (+ Ethernet)	Order No. GJR5 2530 00 R0270
Basic unit 07 KT <b>97</b> R0272 (+ Ethernet + PROFIBUS-DP)	Order No. GJR5 2530 00 R0272
Basic unit 07 KT <b>97</b> R0276 (+ Ethernet + ARCNET)	Order No. GJR5 2530 00 R0276
Basic unit 07 KT <b>97</b> R0277 (+ Ethernet + Ethernet)	Order No. GJR5 2530 00 R0277
Basic unit 07 KT <b>97</b> R0278 (+ Ethernet + CANopen)	Order No. GJR5 2530 00 R0278
Basic unit 07 KT <b>97</b> R0280 (+ CANopen)	Order No. GJR5 2530 00 R0280

#### Scope of delivery

Basic unit 07 KT 97  
1 5-pole terminal block (5.08 mm)  
1 3-pole terminal block (5.08 mm)  
3 10-pole terminal blocks (3.81 mm)  
4 9-pole terminal blocks (3.81 mm)  
1 5-pole terminal block (3.81 mm)

Basic unit 07 KT **96** R0100  
Basic unit 07 KT **96** R0200

Order No. GJR5 2529 00 R0100  
Order No. GJR5 2529 00 R0200

#### Scope of delivery

Basic unit 07 KT 96  
1 5-pole terminal block (5.08 mm)  
1 3-pole terminal block (5.08 mm)  
2 10-pole terminal blocks (3.81 mm)  
3 9-pole terminal blocks (3.81 mm)

Basic unit 07 KT **95** R0100  
Basic unit 07 KT **95** R0200

Order No. GJR5 2528 00 R0100  
Order No. GJR5 2528 00 R0200

#### Scope of delivery

Basic unit 07 KT 95  
1 5-pole terminal block (5.08 mm)  
1 3-pole terminal block (5.08 mm)  
1 10-pole terminal block (3.81 mm)  
3 9-pole terminal blocks (3.81 mm)  
1 5-pole terminal block (3.81 mm)

### Accessories

System cable 07 SK 90	Order No. GJR5 2502 00 R0001
System cable 07 SK 91	Order No. GJR5 2503 00 R0001
System cable 07 SK 92	Order No. GJR5 2504 00 R0001
Battery module 07 LE 90	Order No. GJR5 2507 00 R0001
SmartMedia Card 07 MC 90 5.0 V 2 MB	Order No. GJR5 2526 00 R0101
SmartMedia Card 07 MC 90 3.3 V 8 MB	Order No. GJR5 2526 00 R0201

### Further literature

System description ABB Procontic CS31 English	Order No. FPTN 4400 04 R2001
System description Advant Controller 31 English	Order No. 1SAC 1316 99 R0201

**2.1.8 Data sheet 07 KT 95 R0100 / R0200 (for further details see 07 KT 97)**  
**Order No. GJR5 2528 00 R0100 / GJR5 2528 00 R0200**

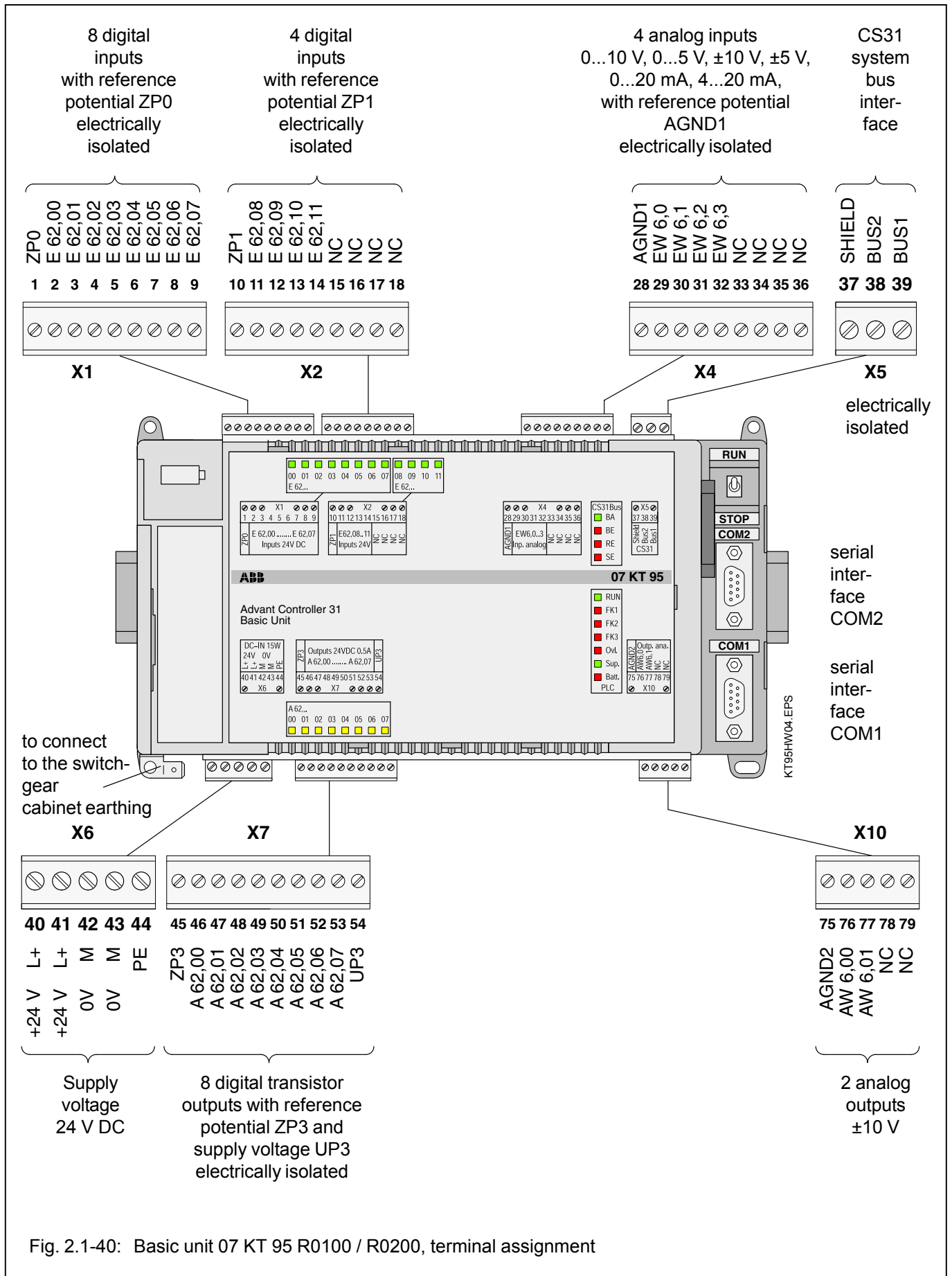

Fig. 2.1-40: Basic unit 07 KT 95 R0100 / R0200, terminal assignment

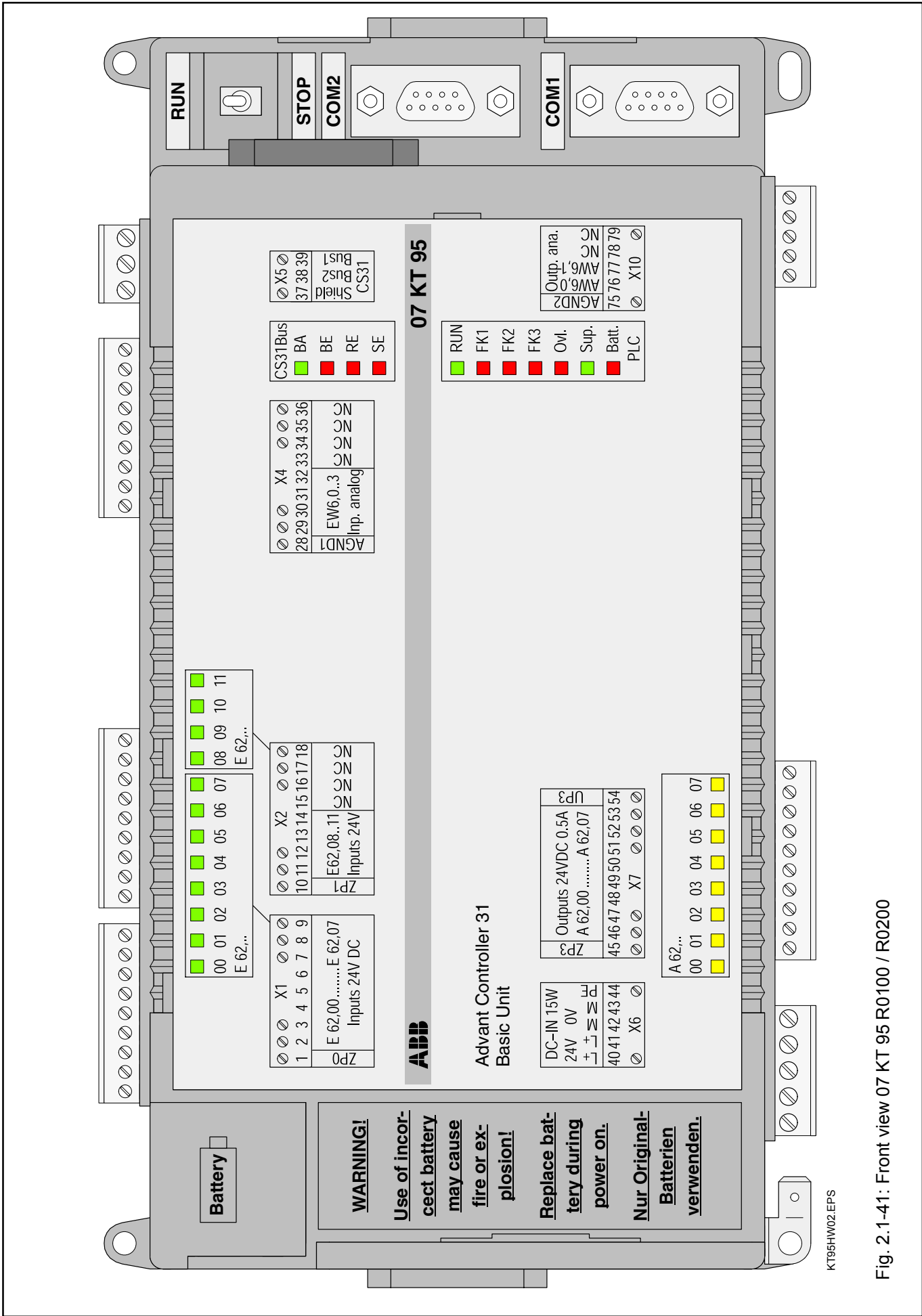

Fig. 2.1-41: Front view 07 KT 95 R0100 / R0200

**2.1.9 Data sheet 07 KT 96 R0100 / R0200 (for further details see 07 KT 97)  
Order No. GJR5 2529 00 R0100 / GJR5 2529 00 R0200**

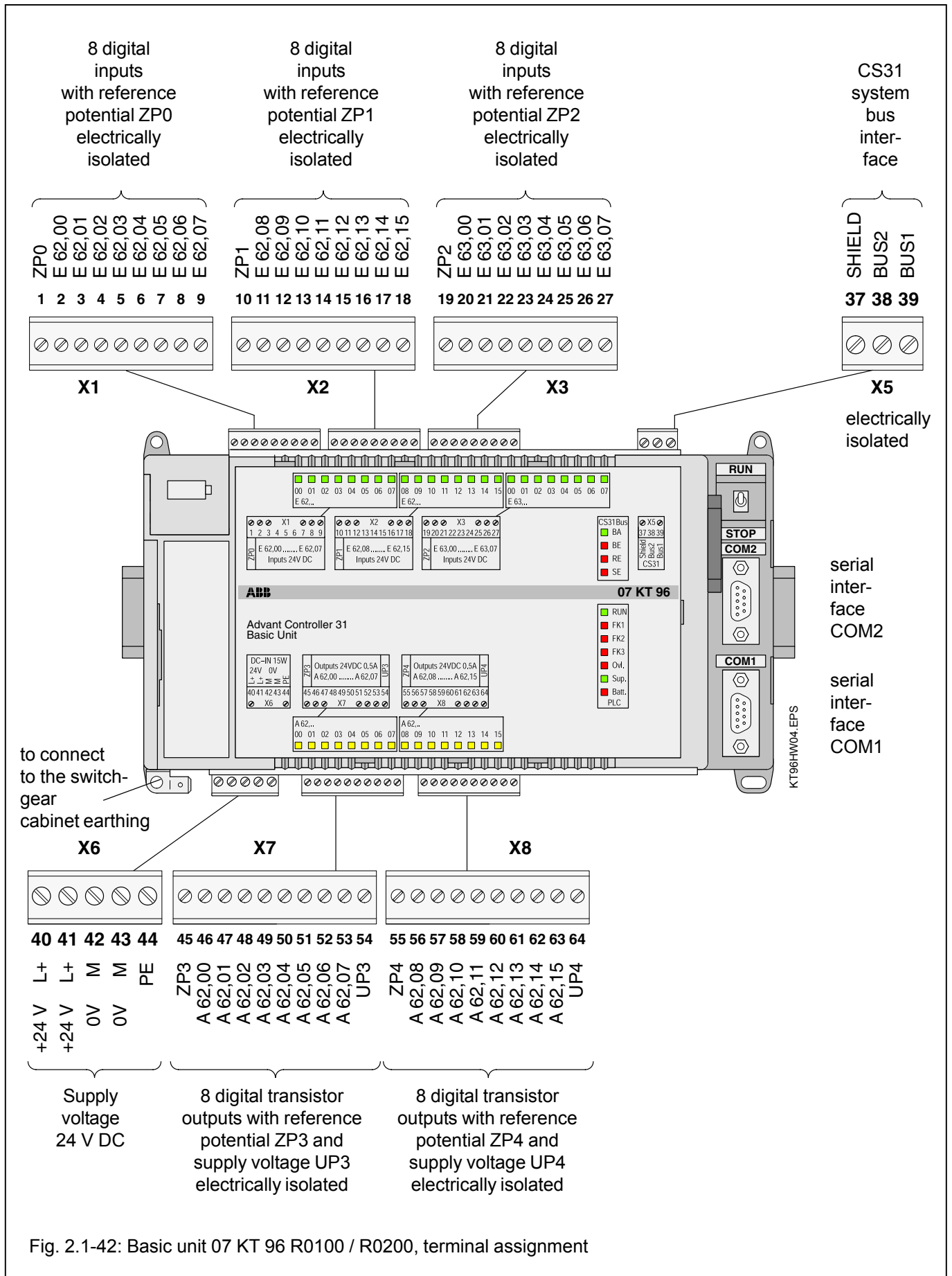

Fig. 2.1-42: Basic unit 07 KT 96 R0100 / R0200, terminal assignment

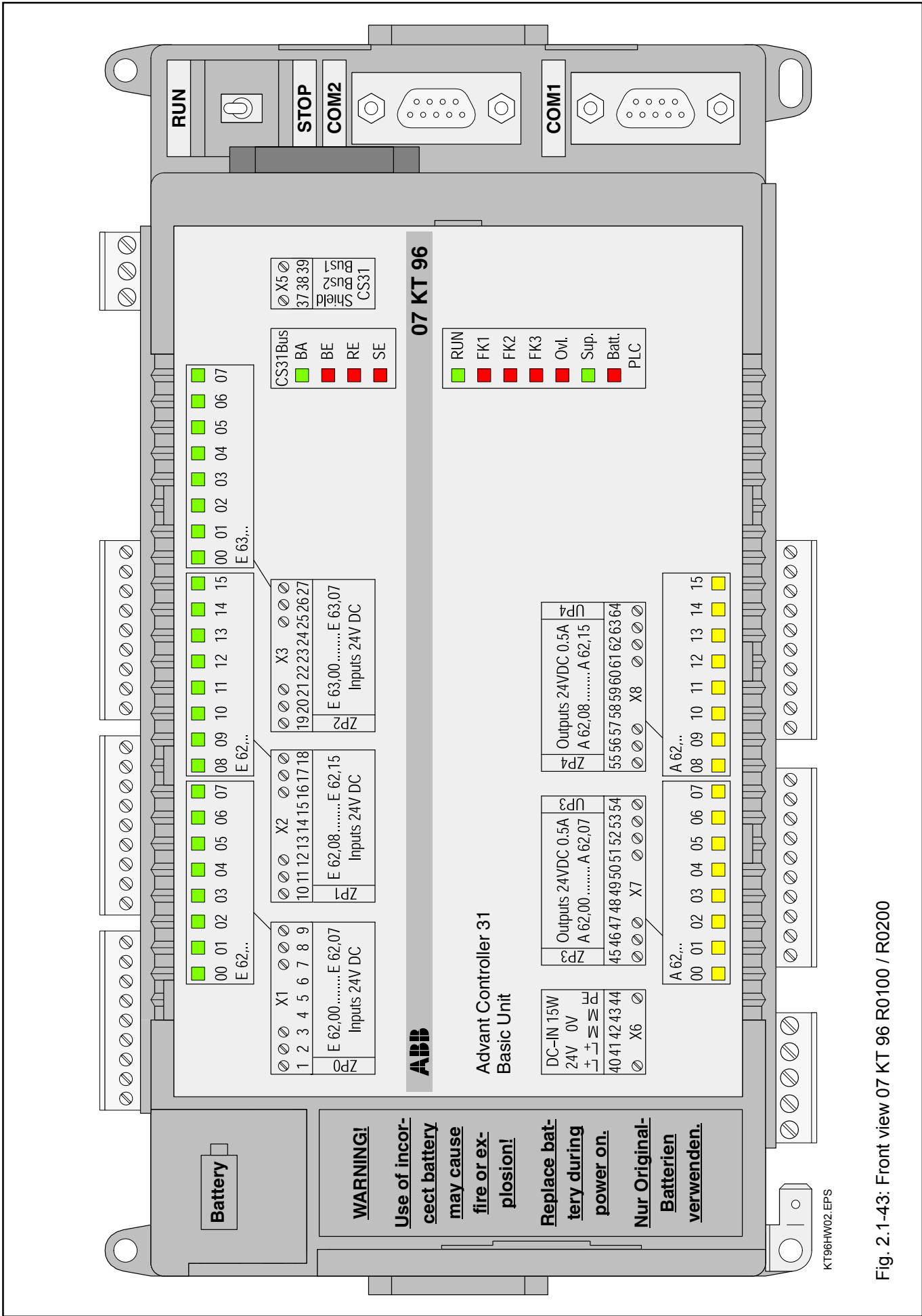

Fig. 2.1-43: Front view 07 KT 96 R0100 / R0200



## 2.1.11 Description of ARCNET

### 2.1.11.1 Basic units with integrated ARCNET coupler

07 KT 97 R0160 (ARCNET)  
 07 KT 97 R0162 (ARCNET + PROFIBUS-DP)  
 07 KT 97 R0260 (ARCNET)  
 07 KT 97 R0262 (ARCNET + PROFIBUS-DP)  
 07 KT 97 R0276 (Ethernet + ARCNET)

Order No. GJR5 2530 00 R0160  
 Order No. GJR5 2530 00 R0162  
 Order No. GJR5 2530 00 R0260  
 Order No. GJR5 2530 00 R0262  
 Order No. GJR5 2530 00 R0276

### 2.1.11.2 Technical data

Connector X4	BNC
ARCNET interface	for coaxial cable
Recommended system cable	coaxial cable Type RG-62/U (char. impedance 93 Ω)
Cable length	305 m in case of ARCNET bus with 8 stations. For further details see SMC TECHNICAL NOTE TN7-1.
Signalling	operating condition "controller active", i.e. the PLC performs writing or reading operations
	operating condition "transmit active", i.e. the PLC is sending on the ARCNET
Electrical isolation	versus power supply voltage, inputs and outputs, versus the interfaces COM1/COM2

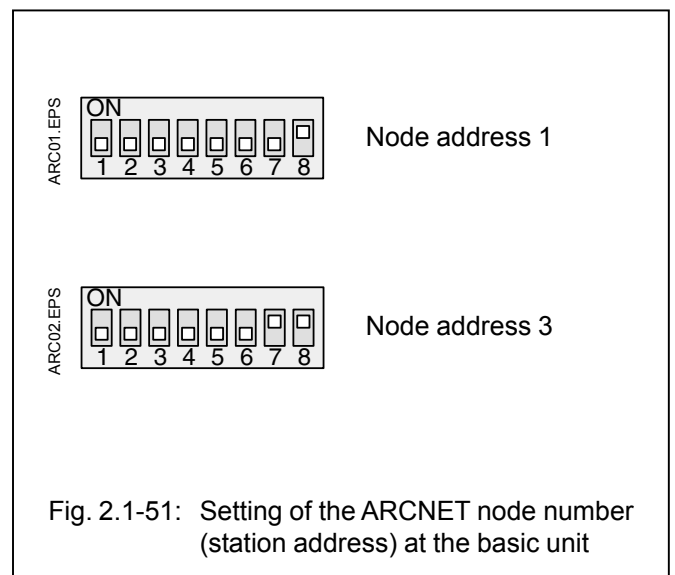
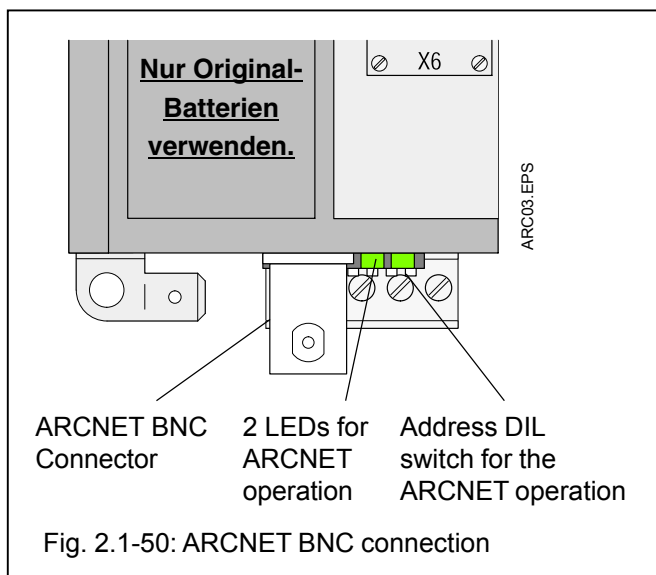

### 2.1.11.3 ARCNET short description

- The ARCNET coupler is integrated in the housing of the basic unit. The DIL switch for setting the ARCNET address is accessible from the outside of the housing. The ARCNET coupler is powered by the internal 24 V DC supply voltage.
- **Note:** The ARCNET interface is located on the upper side of the basic unit if there is also an Ethernet interface integrated.
- For ARCNET coupling, several function blocks are available.
- The ARCNET coupler interface is designed as a bus with BNC connector for coaxial cable. The ARCNET bus is earthed inside the module via a capacitor. As an EMC measure and for protection against dangerous contact voltages, the bus has to be earthed directly at a central place.
- Using the simplest configuration, called Linear ARCNET, a coaxial cable (RG-62, 93 Ω) is laid from station to station and connected with T plugs at all stations. At both ends of the cable, terminating resistors with 93 Ω each have to be installed.

#### 2.1.11.4 The ARCNET system (Attached Resource Computer Network)

- ARCNET is a system for data transmission in local networks.
- The ARCNET protocol is based on the Token Passing principle.
- By passing an identifier (token) from station to station it is guaranteed, that only one station can start a data transmission (transmission without collisions).
- The order of sequence, in which the stations are accessed, is automatically adapted by the existing conditions in the network, i.e. that the network is reconfigured automatically each time a station is added to the network or switched off.

##### 2.1.11.4.1 The networking configurations

###### Linear ARCNET

- In the Linear ARCNET configuration, the stations are connected to one another directly, i.e. without using any distribution units.
- Each station is connected to the network by using a T connector.
- Both cable ends must be terminated by termination resistors.
- A maximum of 8 stations can be connected to one Linear ARCNET.
- The maximum cable length of the network is 300 m.
- An additional segment can be connected at the end of the wired segment via an Active Hub (active distribution unit), see next page.

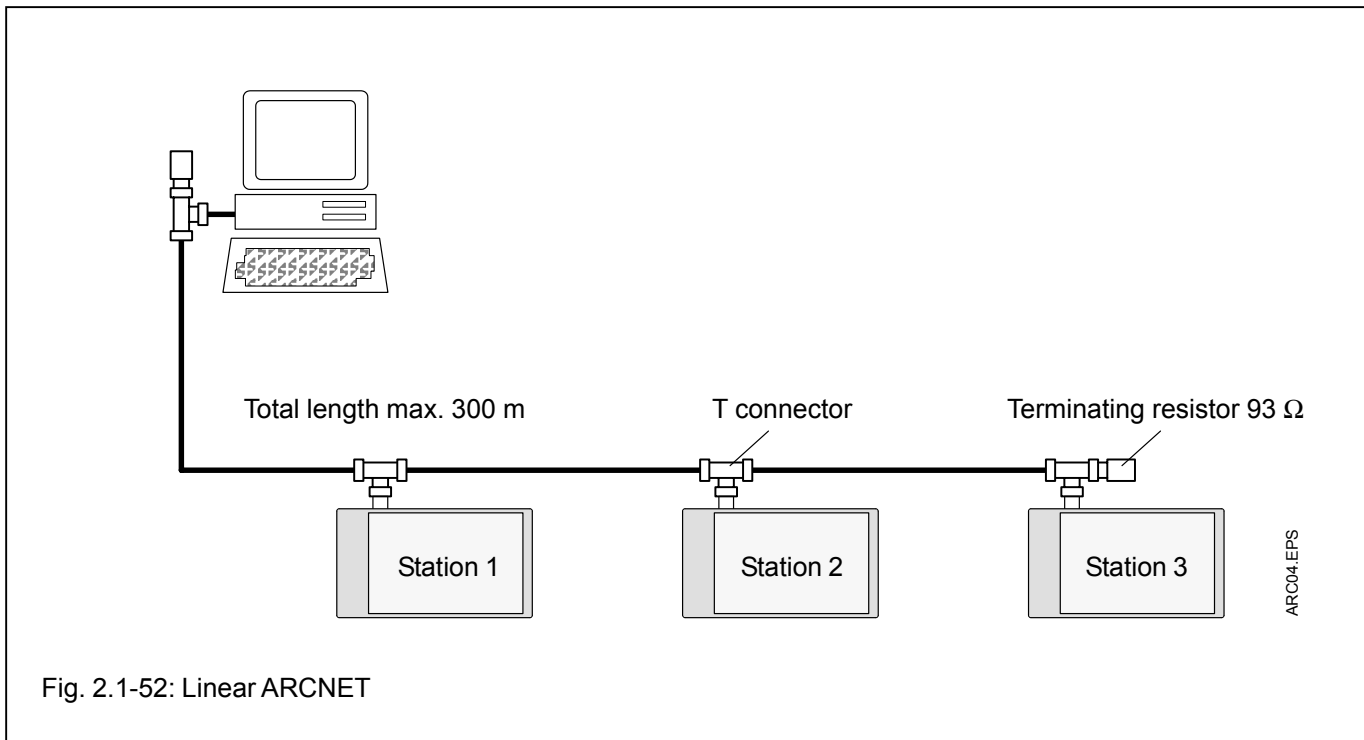

Fig. 2.1-52: Linear ARCNET

**Linear ARCNET, expanded by active distribution units (Active Hubs)**

- Active Hubs amplify the arriving signals. So they stabilize the network configuration and allow especially for high distances. The Active Hub decouples the station connectors from one another.

Therefore, the entire network does not fail when one of the connections fails.

- The maximum length of the network is 6 km.
- A maximum of 255 stations can be used.

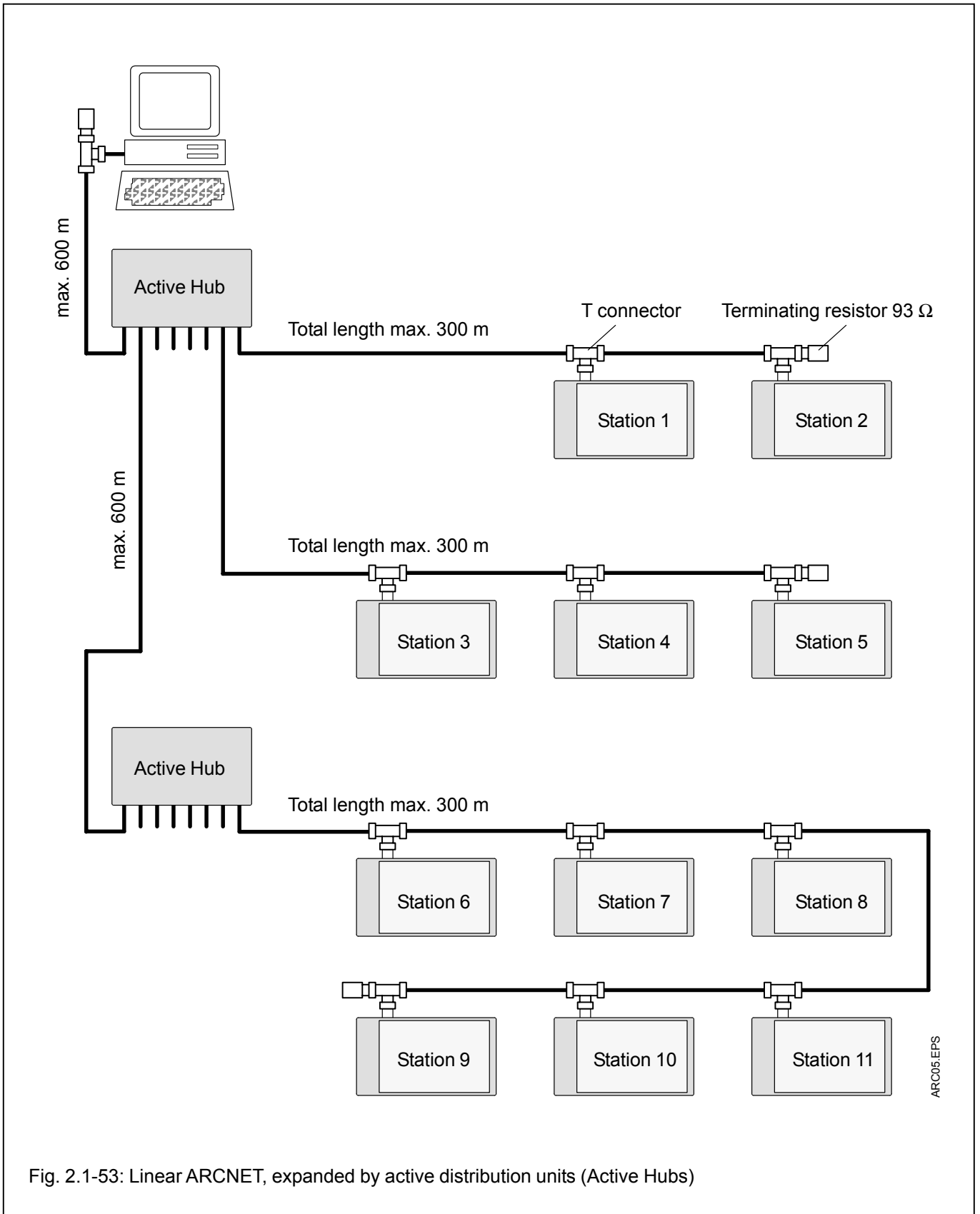

Fig. 2.1-53: Linear ARCNET, expanded by active distribution units (Active Hubs)

ARC05.EPS

#### 2.1.11.4.2 The features of the ARCNET system

- Data transmission rate 2.5 MBit/s
- Coaxial cable of type RG62/U, 93  $\Omega$
- Coaxial plugs, suitable for the coaxial cable
- Maximum number of stations: 255

#### Maximum distances

- The maximum distance between two stations amounts to 6 km.
- The maximum distance between an Active Hub and an ARCNET station or between two Active Hubs amounts to 600 m.
- The maximum distance between a Passive Hub and an ARCNET station or between an Active Hub and a Passive Hub is 30 m. A Passive Hub works like a resistor network which carries out the cable termination at the stations.
- The maximum distance within a Linear ARCNET configuration is 300 m. A maximum of 8 stations can be connected.

## 2.1.12 Description of the PROFIBUS-DP coupler

### 2.1.12.1 Basic units with integrated PROFIBUS-DP coupler

07 KT 97 R120 (PROFIBUS-DP)	Order No. GJR5 2530 00 R0120
07 KT 97 R162 (ARCNET + PROFIBUS-DP)	Order No. GJR5 2530 00 R0162
07 KT 97 R220 (PROFIBUS-DP)	Order No. GJR5 2530 00 R0220
07 KT 97 R262 (ARCNET + PROFIBUS-DP)	Order No. GJR5 2530 00 R0262
07 KT 97 R272 (Ethernet + PROFIBUS-DP)	Order No. GJR5 2530 00 R0272

### 2.1.12.2 Technical data of the integrated coupler

Coupler type	PROFIBUS coupler in PC/104 format
Processor	8-Bit processor with interrupt and DMA controller
Memory available	8 kByte DP RAM, 512 kByte Flash EPROM, 368 kByte RAM
Internal supply with	+5 V, 600 mA
Dimensions	96 x 91 x 13 mm

### 2.1.12.3 Technical data of the interface

Interface connector	9-pole SUB-D, female
Transmission standard	EIA RS-485
Transmission protocol	PROFIBUS-DP
Recommended system cable	shielded and twisted 2-core wire
Characteristic impedance	135...165 $\Omega$
Cable capacitance	< 30 pF/m
Diameter of the wire cores (copper)	> 0.64 mm
Cross section of the cable cores	> 0.32 mm <sup>2</sup>
Wire resistance per core	< 55 $\Omega$ /km
Loop resistance (resistance of 2 cores)	< 110 $\Omega$ /km
Transmission speed (baud rate)	9.6 kBit/s bis 12000 kBit/s
Maximum cable length	1200 m with baud rate 9.6 / 19.2 / 93.75 kBit/s 1000 m with baud rate 187.5 kBit/s 400 m with baud rate 500 kBit/s 200 m with baud rate 1500 kBit/s 100 m with baud rate 3000 / 6000 / 12000 kBit/s
Spur lines	are only permitted up to max. 1500 kBit/s, they should be prevented with 500 kBit/s or more for security purposes
Electrical isolation of the interface	test voltage max. 850 V
Display of statuses	with 4 LEDs (see Fig. 2.1-56)
Number of participants (masters/slaves) per bus segment	max. 32
Number of participants via repeater	max. 126

## 2.1.12.4 PROFIBUS-DP coupler

### Definitions, terms, abbreviations

PROFIBUS-DP	<b>PROCESS FIELDBUS - DECENTRAL PERIPHERY</b>
DP master (class 1)	normal bus master
DP master (class 2)	commissioning device
DP slave (DPS)	I/O module
DPV1	guideline for extended functions for PROFIBUS-DP
PNO	<b>PROFIBUS Nutzer-Organis-</b> sation (user organization)

### Standardization

EN 50170, DIN 19245 Part 1, DIN 19245 Part 3, DPV1

### Basics

PROFIBUS-DP is intended for fast data exchange in the field area. Here, central control units (e.g. PLC/PC) communicate with decentralized field devices like I/O, drives and valves via a fast serial connection. The data exchange with the decentralized modules is mainly performed cyclically. The communication functions, required for data exchange, are defined by the PROFIBUS-DP basic functions in accordance to EN 50170. For parametrization, diagnosis and alarm handling during the running cyclic data exchange, also non-cyclic communication functions are necessary for intelligent field devices.

### Location

The PROFIBUS-DP coupler is integrated in the housing of the basic unit. The bus interface is located on the top side to the left of the basic unit. There are also 4 LEDs for displaying statuses.

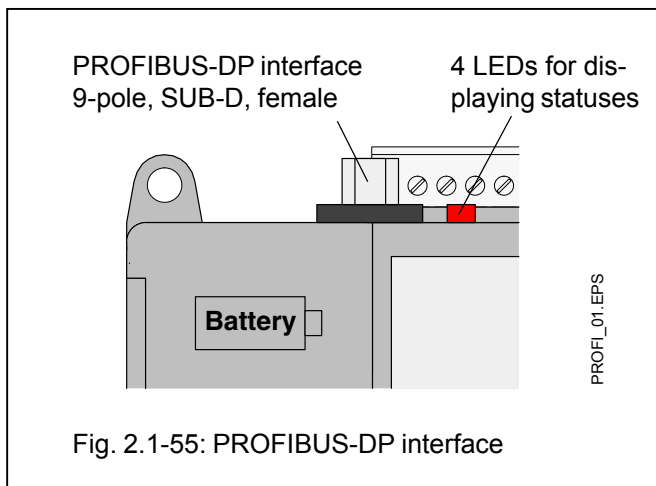

Fig. 2.1-55: PROFIBUS-DP interface

### Pin assignment, meaning of the LEDs

The following figure shows the pin assignment of the PROFIBUS-DP interface as well as the names of the 4 LEDs. The drawing is shown looking from the front side (as mounted in the switch-gear cabinet).

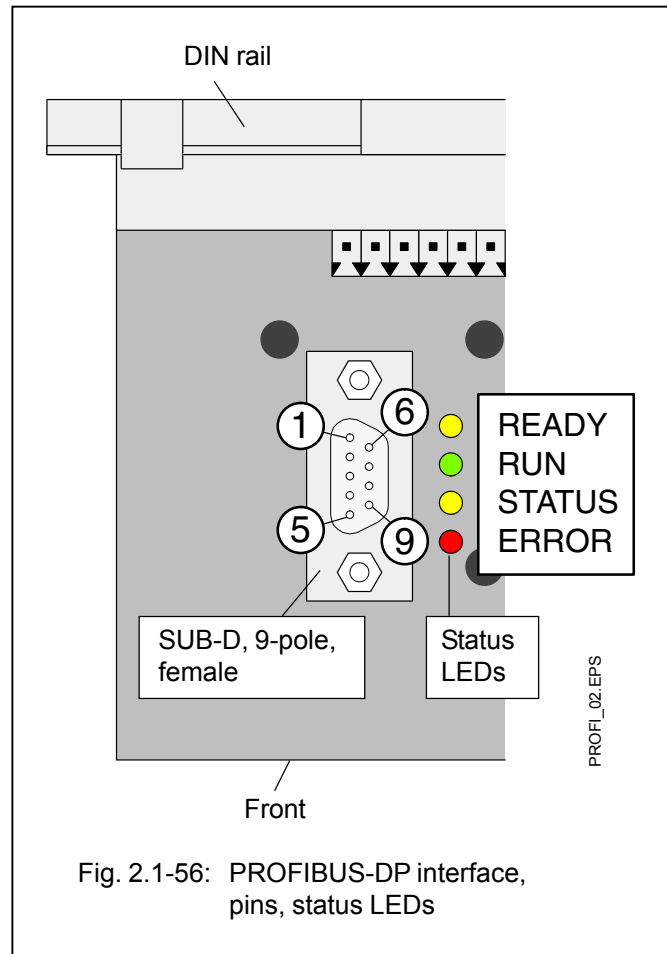

Fig. 2.1-56: PROFIBUS-DP interface, pins, status LEDs

### Pin assignment (SUB-D, 9-pole, female)

Pin No.	Signal	Meaning
1	Shield	shielding, protection earth
2	unused	
3	RxD/TxD-P	receive/transmit line, positive
4	CNTR-P	control signal for repeater, positive
5	DGND	reference potential for data exchange and +5 V
6	VP	+5 V (power supply for the bus terminating resistors)
7	unused	
8	RxD/TxD-N	receive/transmit line, negative
9	CNTR-N	control signal for repeater, negative

## Bus termination

The line ends (of the bus segments) must be equipped with bus termination resistors (show the drawing to the right). Normally, the resistors are integrated in the interface connectors.

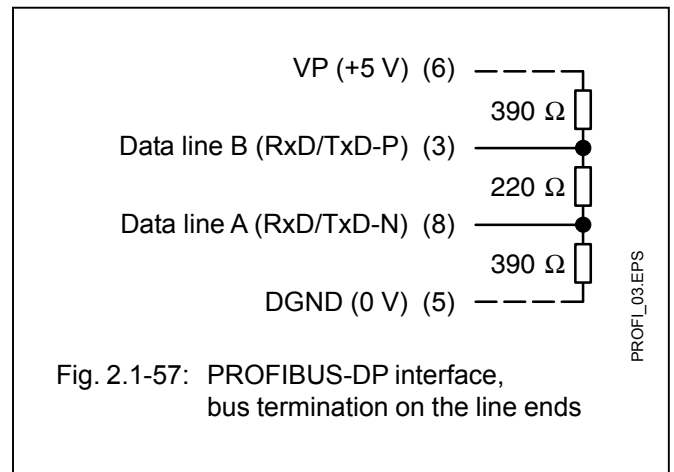

Fig. 2.1-57: PROFIBUS-DP interface, bus termination on the line ends

## Status LEDs

LED	Color	Condition	Meaning
READY	yellow	on flashes cyclic flashes non-cyclic off	coupler ready bootstrap loader active hardware or system error defective hardware
RUN	green	on flashes cyclic flashes non-cyclic off	communication is running communication is stalled missing or erroneous configuration no communication
STATUS	yellow	on  off	DP slave: data exchange with DP master DP master: transmits data or token DP slave: no data exchange DP master: no token
ERROR	red	on off	PROFIBUS error no error

The condition of the PROFIBUS coupler is indicated with the 4 status LEDs.

After power ON the coupler initializes a self-test. If this test was successful, the yellow READY LED goes ON. Otherwise the LED starts flashing and aborts the further initialization. If the LED remains OFF, the coupler is defective.

In the course of initialization, the RUN LED is OFF for the first time. The LED is only activated after configuration data has been sent to the coupler and the operating mode of the coupler was set. If the operating system of the coupler detects a parameterization or a configuration error, the green RUN LED flashes non-cyclically. If this LED flashes cyclically, the coupler is ready for communication, but the communication is not active yet. In case of an active communication, the RUN LED lights continuously.

The red ERROR LED indicates errors on the PROFIBUS interface.

In the operating mode DP slave, the yellow STATUS LED indicates the active I/O data exchange with the DP master. In the operating mode DP master, the STATUS LED indicates the ownership of the token and therefore the I/O data exchange with the involved DP slaves.

During the initialization procedure and also if the coupler is configured (anew) - in particular if the operating mode was changed - it can occur that all or some LEDs light up for a short period of time, before reaching a defined condition.

### Important address

PROFIBUS Nutzerorganisation e. V. (PNO)  
Haid-und-Neu-Straße 7  
D-76131 Karlsruhe

Tel.: (+49) 721 9658 590

Fax: (+49) 721 9658 589

Internet: <http://www.profibus.com>

## 2.1.13 Description of the CANopen Master coupler

### 2.1.13.1 Basic units with an integrated CANopen Master coupler

07 KT 97 R278 (Ethernet + CANopen)  
07 KT 97 R280 (CANopen)

Order No. GJR5 2530 00 R0278  
Order No. GJR5 2530 00 R0280

### 2.1.13.2 Technical data of the integrated coupler

Coupler type	CANopen Master coupler in PC/104 format
Processor	16-bit processor with interrupt and DMA controller
Memory available	8 kbyte DP-RAM, 512 kbyte Flash EPROM, 128 kbyte RAM
Internal supply with	+5 V, 650 mA
Dimensions	96 x 90 x 23 mm
CE sign	55011 Class b for emission, EN 50082-2 for noise immunity

### 2.1.13.3 Technical data of the interface

Interface connector	5-pole COMBICON, female
Transmission standard	ISO 11898, isolated
Transmission protocol	CANopen (CAN), max. 1 MBaud
Transmission speed (baud rate)	20 kbit/s, 125 kbit/s, 250 kbit/s, 500 kbit/s und 1 Mbit/s
Display of statuses	by 4 LEDs (see Fig. 2.2-59)
Number of participants	max. 127 slaves

### 2.1.13.4 Short description

CANopen is a standardized 7-layer protocol for decentralized industrial automation systems, based on the Controller Area Network (CAN) and the CAN Application Layer (CAL).

CANopen bases on a communication profile in which the basic communication mechanisms and their descriptions are defined, e.g. mechanisms for interchange of process data in real time or transmitting of alarm messages.

The different CANopen device profiles make use of this common communication profile. The device profiles describe the specific functionality of a device class or its parameters. For the most important device classes used in the industrial automation technology, such as digital and analog input/output modules, sensors, drives, operator panels, loop controllers, programmable control systems and encoders, suitable device profiles exist. Others are in preparation.

A central element of the CANopen standard is the description of the device functionality in an object directory.

The object directory is subdivided into a general part and a device-specific part. The general part contains details on the device, such as device identification, name of manufacturer, communication parameters etc. The device-specific part describes the specific functionality of the concerned device. These features of a CANopen device are described in a standardized Electronic Data Sheet (EDS).

A CANopen network consists of a maximum of 128 devices, one NMT master and a maximum of 127 NMT slaves. In contrast to other typical master-slave systems such as PROFIBUS, the CANopen terms Master and Slave have a different meaning.

In operational mode, all devices are able to transmit messages via the bus. In addition, the master can change the operating mode of the slaves.

Normally a CANopen master is realized by a PLC or a PC. The bus address of a CANopen slave can be set from 1 to 127. By the device address, a number of identifiers are created, which are then used by the device.



### 2.1.13.5 Location

The CANopen coupler is integrated in the housing of the basic unit. The bus interface is located on the top side to the left of the basic unit. There are also the 4 LEDs for displaying statuses.

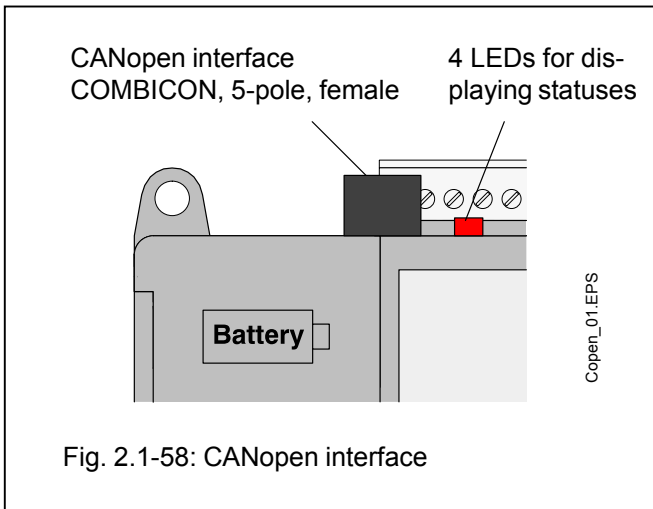

Fig. 2.1-58: CANopen interface

### 2.1.13.6 Pin assignment, meaning of the LEDs

The following figure shows the pin assignment of the CANopen interface as well as the names of the 4 LEDs. The drawing is shown looking from the front side (as mounted in the switch-gear cabinet).

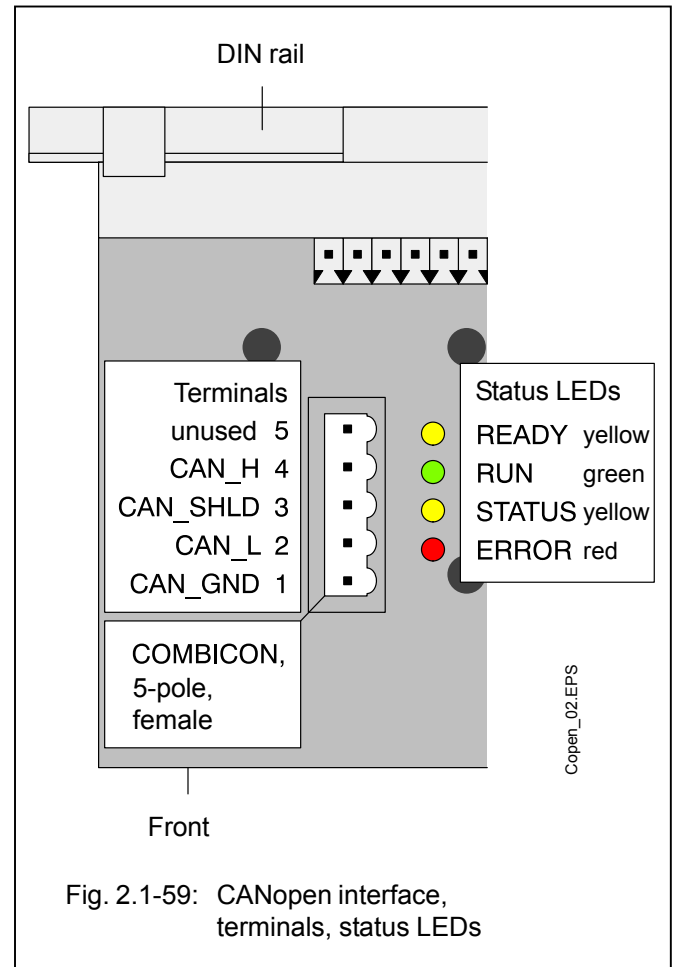

Fig. 2.1-59: CANopen interface, terminals, status LEDs

#### Terminal assignment (COMBICON, 5-pole, female)

Pin No.	Signal	Meaning
1	CAN_GND	CAN Ground
2	CAN_L	CAN_L bus line, Receive/Transmit low
3	CAN_SHLD	Shield of the bus cable
4	CAN_H	CAN_H bus line, Receive/Transmit high
5	unused	

## Status LEDs

LED	Color	Condition	Meaning
READY	yellow	on flashes cyclic flashes non-cyclic off	Coupler ready Bootstrap loader active Hardware or system error Defective hardware
RUN	green	on flashes cyclic flashes non-cyclic off	Communication is running Communication is stalled Missing or faulty configuration No communication
STATUS	yellow	on off	Coupler transmits data Coupler does not transmit data
ERROR	red	on off	CANopen error No error

### 2.1.13.7 Bus termination

The data line ends must be equipped with 120-Ohm bus terminating resistors. Normally, the resistors are integrated in the interface connectors.

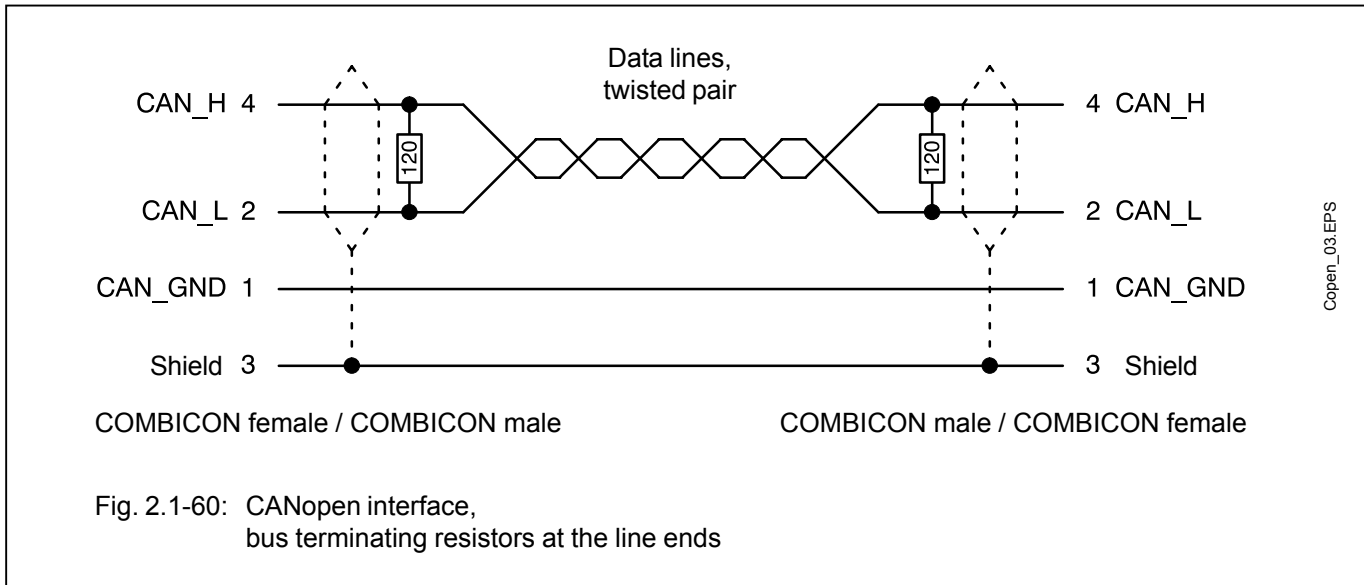

## 2.1.14 Description of the Ethernet coupler

### 2.1.14.1 Basic units with integrated Ethernet coupler

07 KT 97 R270 (Ethernet)	Order No. GJR5 2530 00 R0270
07 KT 97 R272 (Ethernet + PROFIBUS-DP)	Order No. GJR5 2530 00 R0272
07 KT 97 R276 (Ethernet + ARCNET)	Order No. GJR5 2530 00 R0276
07 KT 97 R277 (Ethernet + Ethernet)	Order No. GJR5 2530 00 R0277
07 KT 97 R278 (Ethernet + CANopen)	Order No. GJR5 2530 00 R0278

### 2.1.14.2 Technical data of the integrated coupler

Coupler type	Ethernet coupler in PC/104 format
Processor	EC1-160, system clock 48 MHz
Ethernet controller	EC1-160, internally
Interfaces	Ethernet Diagnosis
	10 / 100 BASE-TX / RJ45 MiniDIN, 8-pole, female
LED displays	RDY - System o.k. RUN - Configuration o.k. / Communication is running ERR - Communication error STA - Status of the Ethernet communication
Setting the station identifier	00 <sub>H</sub> to FF <sub>H</sub>
Internal supply with	+5 V, 300 mA
Dimensions	90 x 96 x 23 mm

### 2.1.14.3 Technical data of the software

Firmware	Protocol suite	UDP/IP TCP/IP Open MODBUS on TCP others in preparation
	EthernetIP	Slave only Cyclic and non-cyclic data transfer

### 2.1.14.4 Short description

The Ethernet coupler is an intelligent 100-Base-T-Ethernet communication interface based on the highly integrated microcontroller EC1. The coupler supports the complete TCP/IP protocol and the application layers, too.

The user interface is based on a dual-port memory.

The coupler meets the PC/104 standard. It is powered by the internal 5 V supply voltage.

The Ethernet communication is run via an RJ45 interface. In addition, the coupler has a diagnosis interface in Mini-DIN format.

The coupler is configured via the dual-port memory, the diagnosis interface or a TCP/IP connection by means of a system configurator. The configuration is saved non-volatile in a Flash EPROM.

### 2.1.14.5 Location

The following figure shows a basic unit with two Ethernet couplers, which are located on the bottom side to the left of the basic unit. Units which have only one coupler, use coupler No. 1.

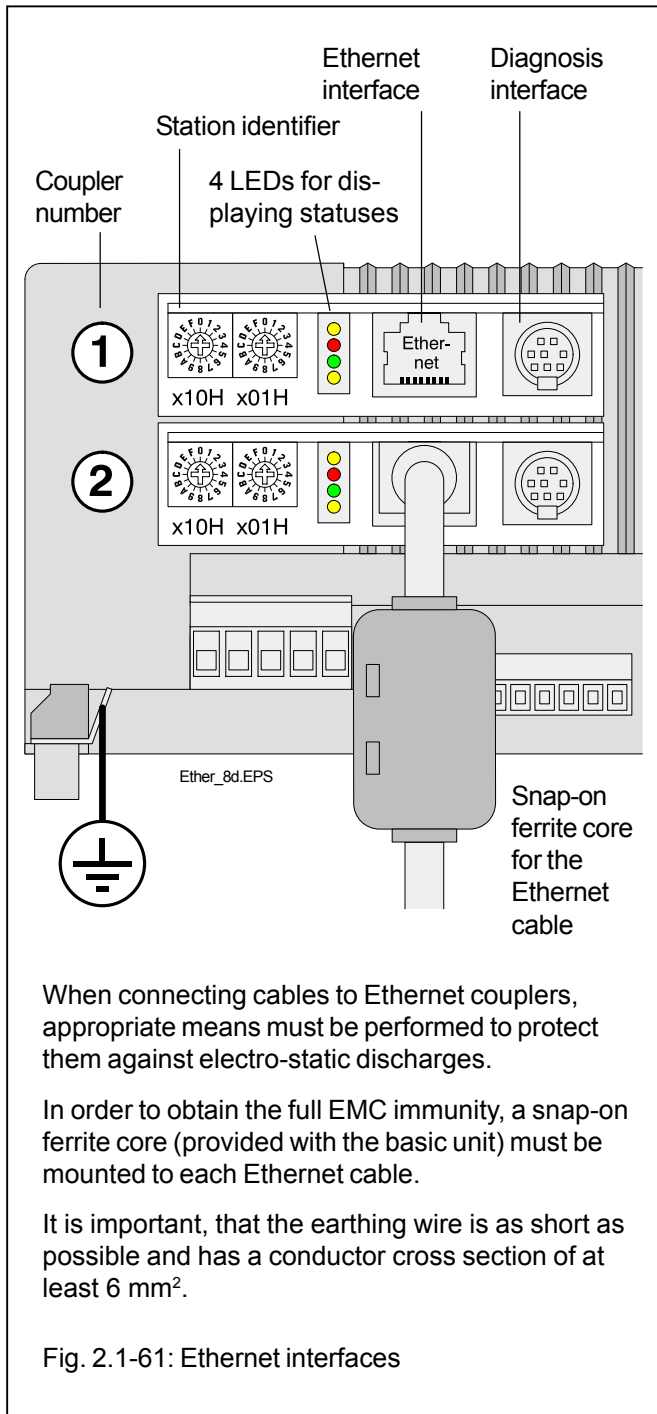

### 2.1.14.6 Station identifier

The following figure shows the setting of the station identifier.

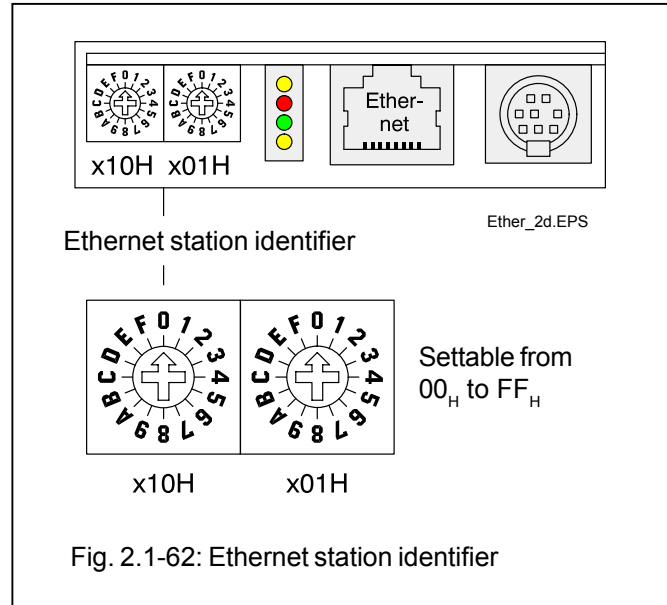

### 2.1.14.7 Ethernet interface

The following figure shows the Ethernet interface.

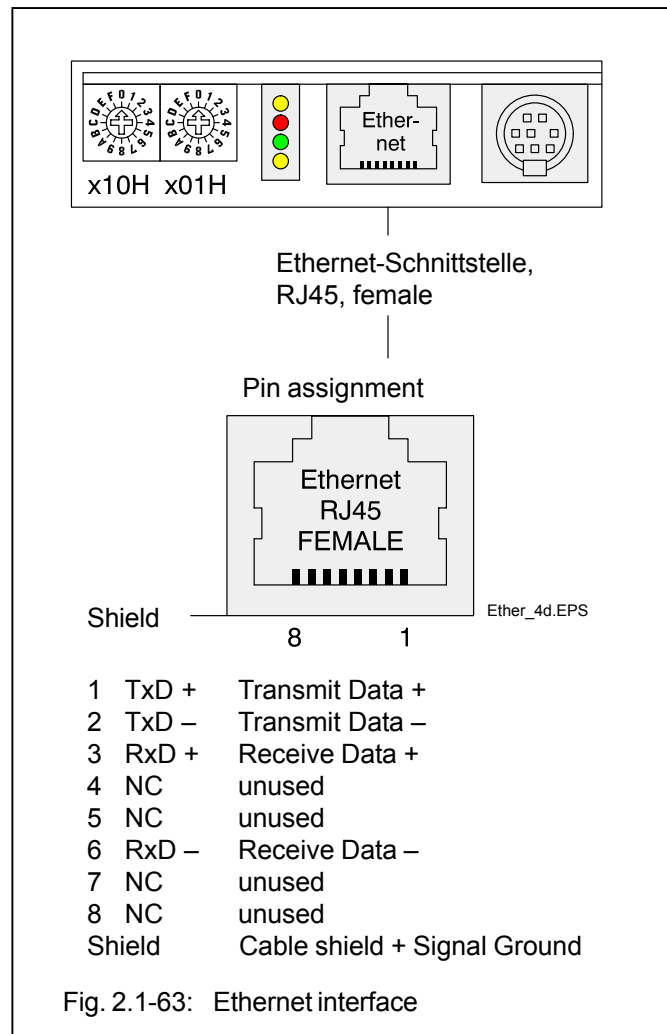

### 2.1.14.8 Diagnosis interface

The following figure shows the diagnosis interface.

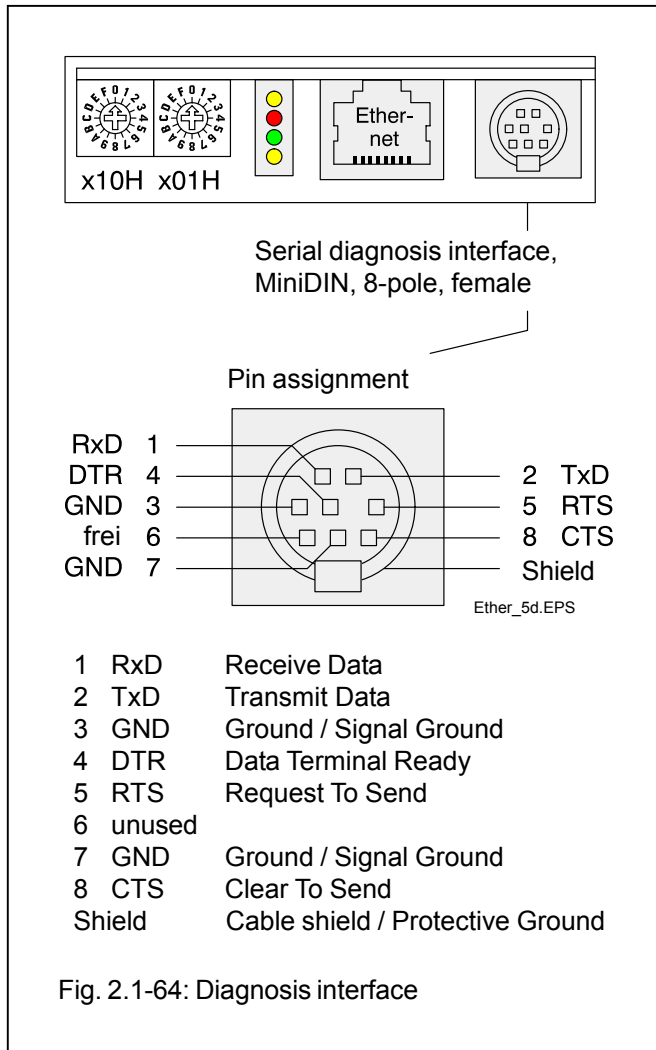

### 2.1.14.9 Meaning of the LEDs

The following figure shows the 4 status LEDs.

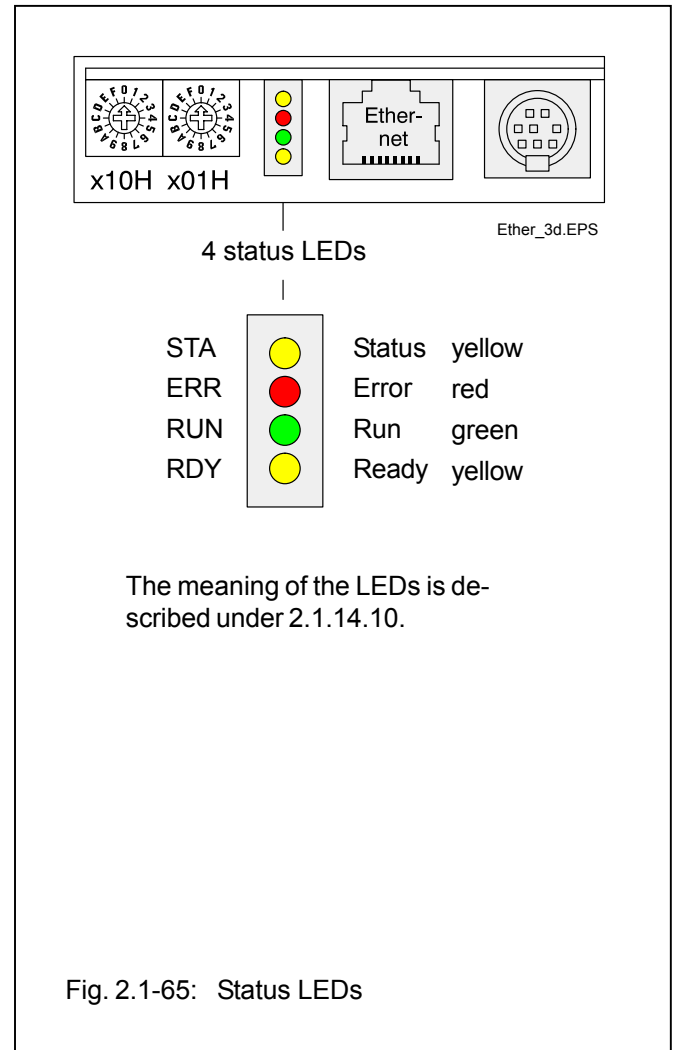

### 2.1.14.10 Status LEDs

LED	Color	Condition	Meaning
STATUS	yellow	flashes	Ethernet frame detected on the network
ERROR	red	on off	Error No error
RUN	green	eon flashes cyclic flashes non-cyclic off	Communication is running Ready for communication Parameterization error No communication
READY	yellow	on flashes cyclic flashes non-cyclic off	Coupler is ready Bootstrap loader is active Hardware or system error Defektive hardware







---

**ABB STOTZ-KONTAKT GmbH**

Eppelheimer Straße 82      Postfach 101680  
69123 Heidelberg      69006 Heidelberg  
Germany      Germany

Telephone    +49 6221 701-0  
Telefax      +49 6221 701-240  
E-Mail        desst.help@de.abb.com  
Internet      <http://www.abb.de/stotz-kontakt>



# Advant Controller 31 Intelligent Decentralized Automation System

## Basic Unit 07 KT 98

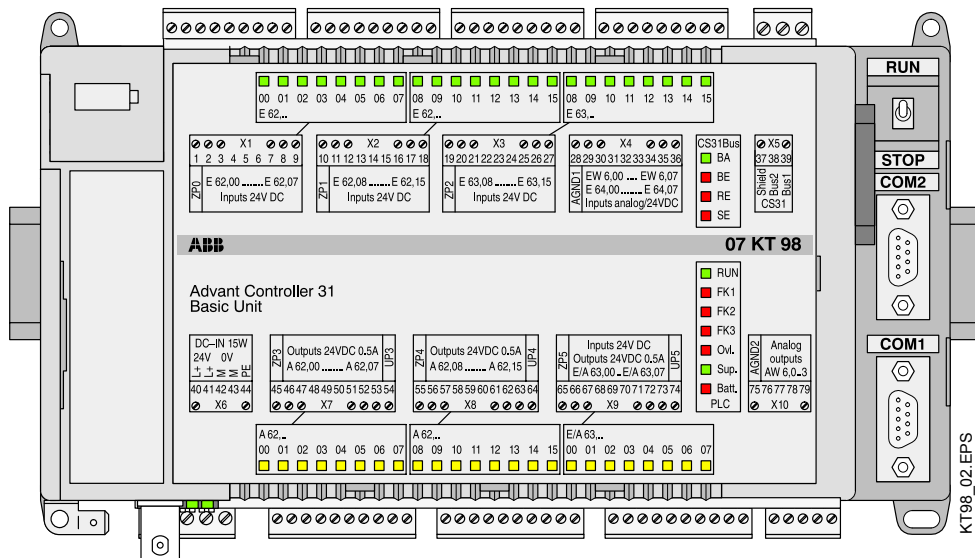



## 2.2 Basic Unit 07 KT 98

Basic unit with max. 1 MB user program

+ 1 MB user data + 256 kB RETAIN, CS31 system bus

The basic unit 07 KT 98 is offered with several networking possibilities. A table on page 2.2-3 shows the features of the different basic units.

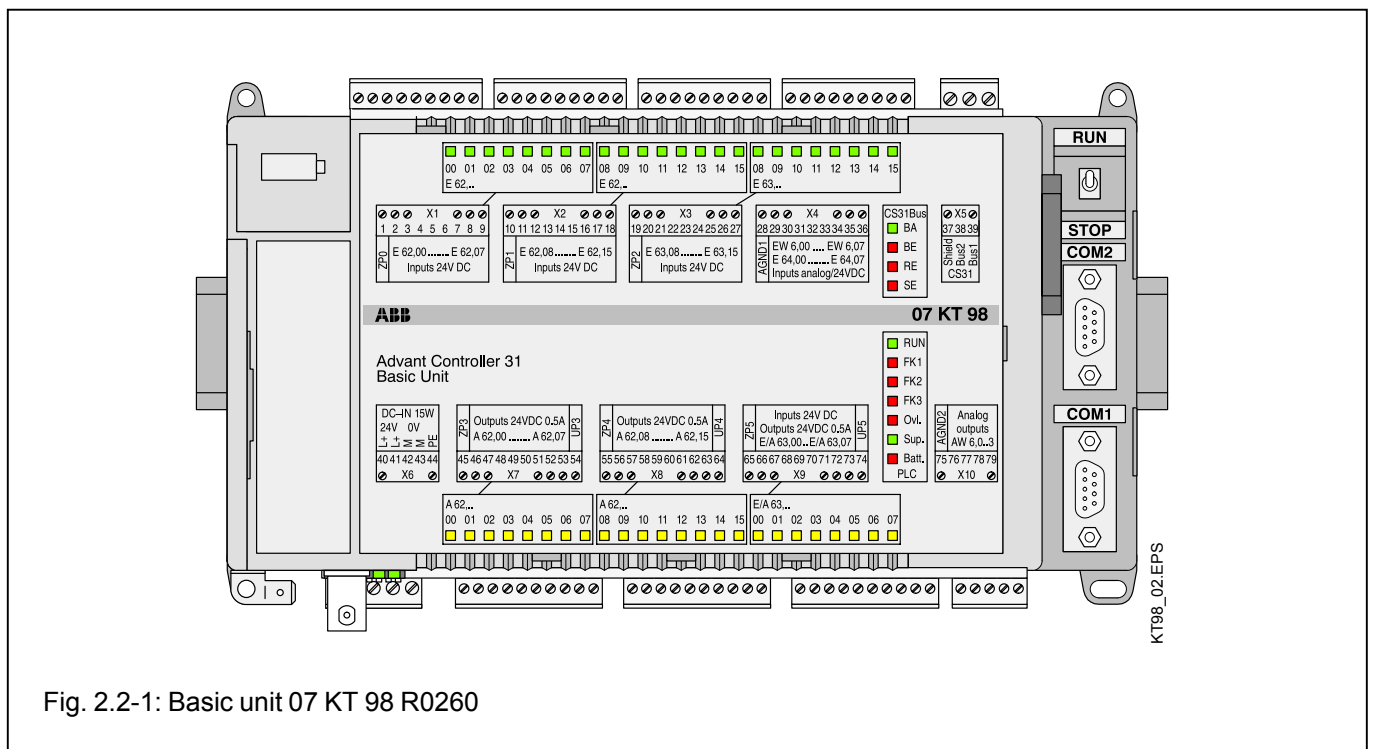

Fig. 2.2-1: Basic unit 07 KT 98 R0260

### Contents

<b>2.2.1</b>	<b>Brief description</b> .....	page 2.2-4
2.2.1.1	Main features .....	4
2.2.1.2	Project planning / Start-up .....	4
<b>2.2.2</b>	<b>Front view</b> .....	5
<b>2.2.3</b>	<b>Structure of the front panel</b> .....	6
2.2.3.1	Terminal assignment overview .....	7
<b>2.2.4</b>	<b>Electrical connection</b> .....	8
2.2.4.1	Application example for input and output wiring .....	8
2.2.4.2	Connection of the supply voltage .....	9
2.2.4.3	Connection of the CS31 system bus .....	9
2.2.4.4	Connection of the digital inputs .....	10
2.2.4.5	Connection of the digital outputs .....	11
2.2.4.6	Connection of the digital inputs/outputs ....	12
2.2.4.7	Connection of the 8 configurable analog inputs .....	13
2.2.4.8	Connection of the 4 configurable analog outputs .....	20
2.2.4.9	Battery and battery replacement .....	21
2.2.4.10	Serial interface COM1 .....	21
2.2.4.11	Serial interface COM2 .....	22
2.2.4.12	Networking interface .....	22
<b>2.2.5</b>	<b>SmartMedia Card</b> .....	23

<b>2.2.6</b>	<b>High-speed counter</b> .....	page 2.2-24
<b>2.2.7</b>	<b>Technical data 07 KT 98</b> .....	25
2.2.7.1	General data .....	25
2.2.7.2	Power supply .....	25
2.2.7.3	Lithium battery .....	26
2.2.7.4	Digital inputs .....	26
2.2.7.5	Digital outputs .....	26
2.2.7.6	Digital inputs/outputs .....	27
2.2.7.7	Analog inputs .....	27
2.2.7.8	Analog outputs .....	28
2.2.7.9	Connection of the serial interfaces COM1 and COM2 .....	29
2.2.7.10	Connection of the CS31 system bus .....	29
2.2.7.12	LED displays .....	30
2.2.7.13	High-speed hardware counter .....	30
2.2.7.14	Mechanical data .....	31
2.2.7.15	Mounting hints .....	31
2.2.7.16	Ordering data .....	32
<b>2.2.11</b>	<b>ARCNET</b> .....	33
<b>2.2.12</b>	<b>PROFIBUS-DP</b> .....	37
<b>2.2.13</b>	<b>CANopen</b> .....	40
<b>2.2.14</b>	<b>Ethernet</b> .....	43

## Functionality of the basic unit 07 KT 98

User program	1 MB
User data	1 MB + 256 kB RETAIN + 128 kB (Flash EPROM)
Digital inputs	24 in 3 groups of 8 each, electrically isolated
Digital outputs	16 transistor outputs in 2 groups of 8 each, electrically isolated
Digital inputs/outputs	8 in 1 group, electrically isolated
Analog inputs	8 in 1 group, individually configurable to 0...10 V, 0...5 V, +10 V, +5 V, 0...20 mA, 4...20 mA, Pt100 (2-wire or 3-wire), differential inputs, digital inputs
Analog outputs	4 in 1 group, individually configurable to 0...10 V, 0...20 mA, 4...20 mA
Serial interfaces	COM1, COM 2 as MODBUS interfaces, for programming and test functions and as freely programmable interfaces
Parallel interfaces for connection of couplers	07 KP 90 (RCOM), 07 KP 93 (2 x MODBUS), 07 MK 92 (freely programmable)
System bus interface	CS31
Integrated couplers	see next page
High-speed counter	integrated, many functions configurable
Real-time clock	integrated
SmartMedia Card	memory medium for operating system, user program and user data
LED displays	for signal conditions, operating statuses and error messages
Power supply voltage	24 V DC
Data backup	with lithium battery 07 LE 90
Programming software	907 AC 1131 as of V 4.1 (07 KT 98 with ARCNET interface) 907 AC 1131 as of V 4.2.1 (07 KT 98 with PROFIBUS-DP interface)

## Differences between the basic units 07 KT 95 to 07 KT 98

Basic unit	07 KT 95	07 KT 96	07 KT 97	07 KT 98		
Number of digital inputs	12	24	24	24		
Number of digital outputs	8	16	16	16		
No. of digital inputs/outputs	-	-	8	8		
Number of analog inputs	4	-	8	8		
Pt100	no	-	yes	yes		
Number of analog outputs	2	-	4	4		
20 mA	no	-	yes	yes		
Are the analog inputs configurable as digital inputs?	no	-	yes	yes		
Terminals	20	E 63,00	E 63,08	E 63,08		
to	-	to	to	to		
27	-	E 63,07	E 63,15	E 63,15		
Processing time, 65 % bits, 35 % words, for 1 kB of program, typ.	0.3 ms	0.3 ms	0.3 ms	0.07 ms		
Order number	GJR5 2528 00 R....	GJR5 2529 00 R....	GJR5 2530 00 R....	GJR5 2531 00 R....		

## Available versions of the basic units 07 KT 95 to 07 KT 98

Version of the basic unit	Integrated (internal) couplers	Version is available with			
		07 KT 95	07 KT 96	07 KT 97	07 KT 98
R0100, R0200	none	◆	◆	◆	
R0120, R0220	PROFIBUS-DP			◆	◆
R0160, R0260	ARCNET			◆	◆
R0162, R0262	ARCNET + PROFIBUS-DP			◆	◆
R0268	ARCNET + CANopen				◆
R0270	Ethernet			◆	◆
R0272	Ethernet + PROFIBUS-DP			◆	◆
R0276	Ethernet + ARCNET			◆	◆
R0277	Ethernet + Ethernet			◆	◆
R0278	Ethernet + CANopen			◆	◆
R0280	CANopen			◆	◆

## Usable SmartMedia Cards

Version of the basic unit	Usable SmartMedia Card	
	07 MC 90, <b>5 V</b> GJR5 2526 00 R0101	07 MC 90, <b>3.3 V</b> GJR5 2526 00 R0201
R0100 to R0199	◆	
R0200 to R0299	◆	◆

## 2.2.1 Brief description

The basic unit 07 KT 98 works either as

- bus master in the decentralized automation system Advant Controller 31 or as
- slave (remote processor) in the decentralized automation system Advant Controller 31 or as
- stand-alone basic unit.

The basic unit is powered by 24 V DC.

### 2.2.1.1 Main features

- 24 digital inputs with LED displays
- 16 digital transistor outputs with LED displays
- 8 digital inputs/outputs with LED displays
- 8 **individually configurable** analog inputs 0...10 V, 0...5 V,  $\pm 10$  V,  $\pm 5$  V, 0...20 mA, 4...20 mA, differential inputs, Pt100 (2-wire or 3-wire), the analog inputs are also individually configurable as digital inputs
- 4 **individually configurable** analog outputs  $\pm 10$  V, 0...20 mA, 4...20 mA
- 2 counters for counting frequencies up to 50 kHz, configurable in 7 different operating modes
- 1 CS31 system bus interface for system expansion
- 1 interface for connecting communication modules (e.g. 07 KP 90)
- 2 serial interfaces COM1, COM2
  - as MODBUS interfaces and
  - for programming and test functions
  - as freely programmable interfaces
- Real-time clock
- LEDs for displaying operating conditions and error messages
- Detachable screw-type terminal blocks
- Fastening by screws or by snapping the device onto a DIN rail
- The lithium battery 07 LE 90 can be put into the battery compartment in order to
  - store and backup data which is additionally contained in the RAM, e.g. the status of flags (RETAIN)
  - backup the time and date (real-time clock)
- RUN/STOP switch for starting and aborting the program execution
- Extensive diagnosis functions
  - self-diagnosis of the basic unit
  - diagnosis of the CS31 system bus and the connected modules

- Integrated Flash EPROM for storing program and data
- Exchangeable SmartMedia Card 07 MC 90 for user data or for updating the operating system or PLC program

### 2.2.1.2 Project planning / start-up

The following has to be observed for project planning and start-up:

- Programming is performed with AC31 programming software, which can be run on commercially available IBM compatible PCs (see documentation of the programming system 907 AC 1131).
- Online program modification  
A quick modification of the user program is possible without interrupting the operation (see programming system 907 AC 1131).
- Possible operating modes
  - Stand-alone basic unit
  - Bus master basic unit
  - Slave basic unit
- Backup of data areas, i.e. saving of data during power OFF/ON, is possible with an integrated battery and/or by storing them in the Flash EPROM.
- When using the PROFIBUS DP interface, project planning is performed in the same way as with 07 KT 97. For details see chapter "System Description".

## 2.2.2 Front view

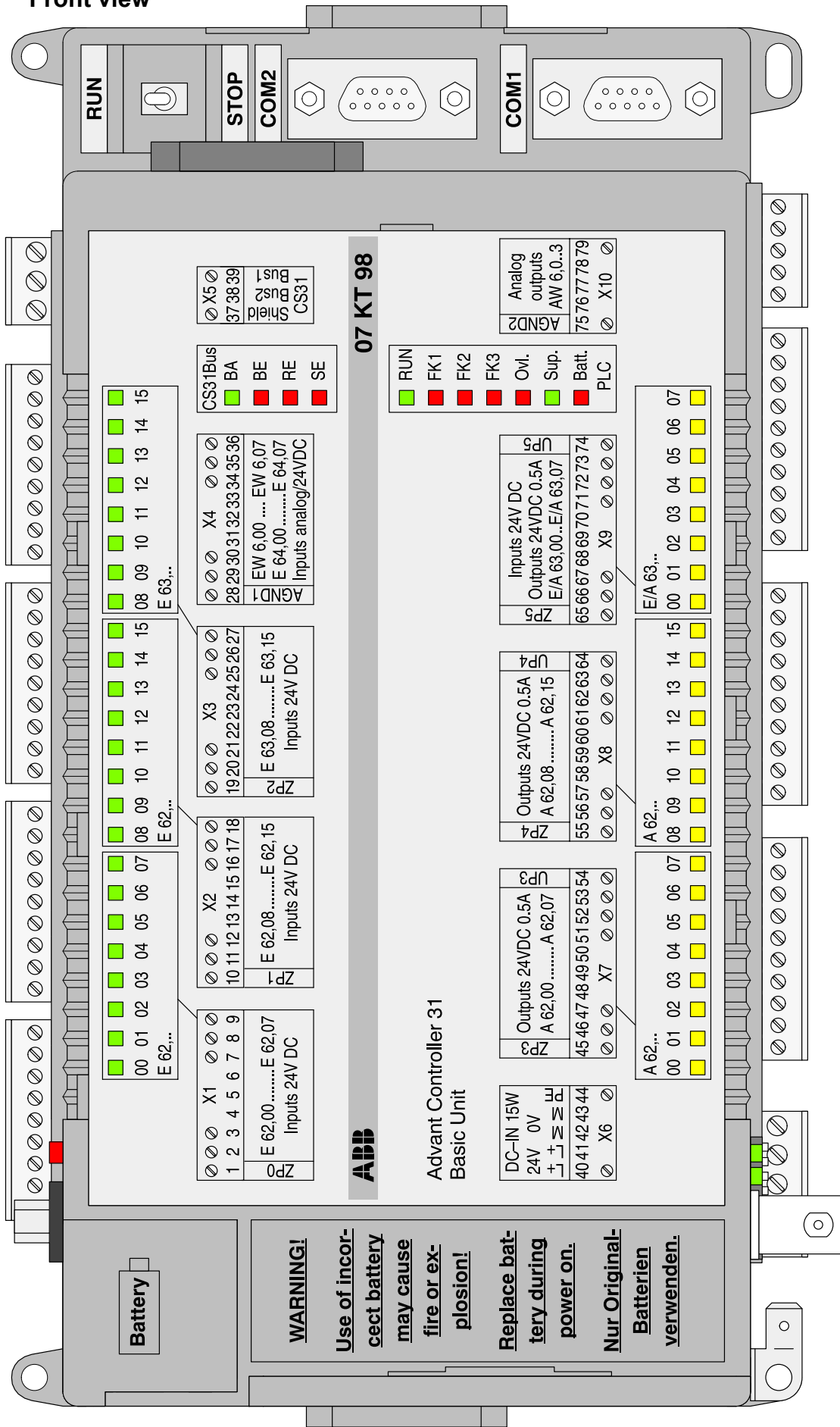

KT98\_05A.EPS

Fig. 2.2-2: Front view 07 KT 98 R262

## 2.2.3 Structure of the front panel

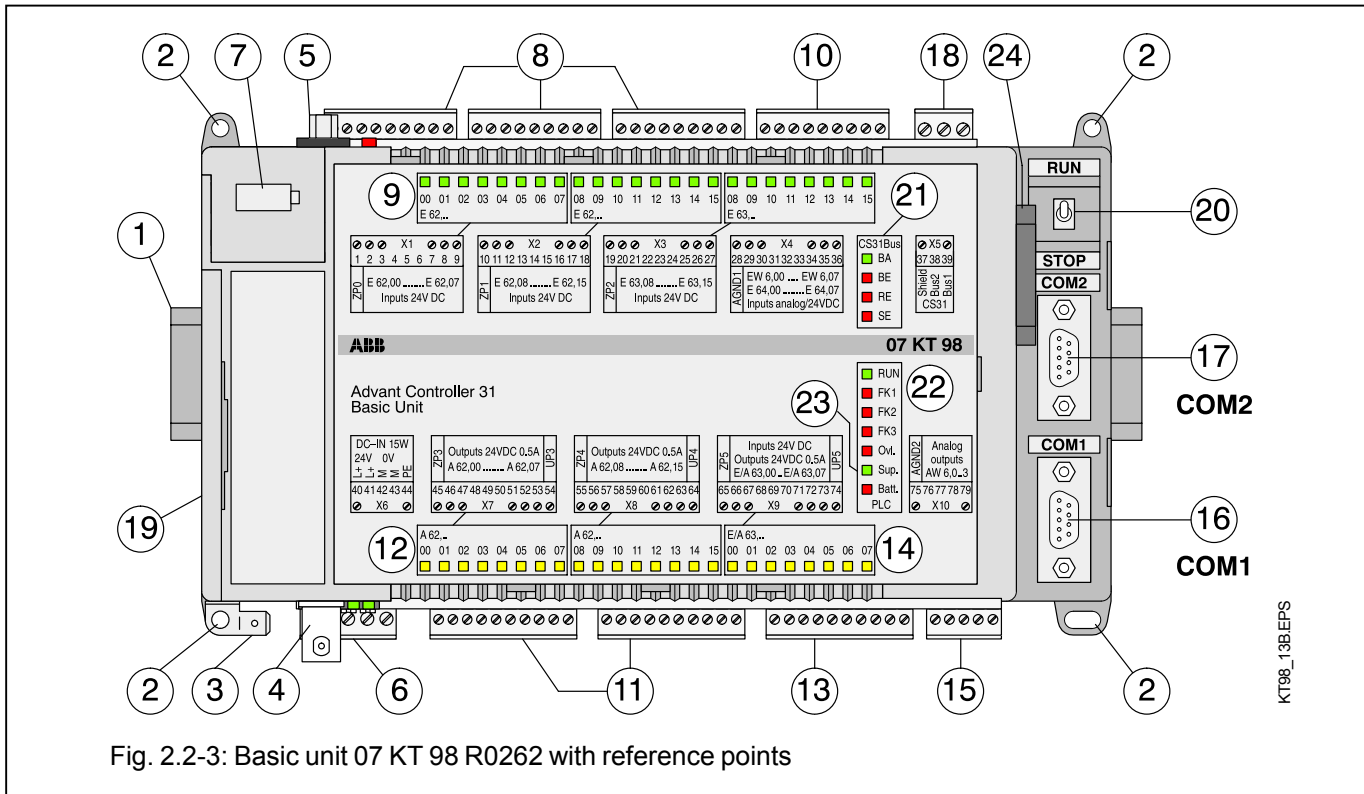

Fig. 2.2-3: Basic unit 07 KT 98 R0262 with reference points

- |   |  |
|---|--|
| (1) Fastening the device on DIN rail  | (18) Connection for CS31 system bus  |
| (2) Fastening the device by screws  | (19) Cover of the interface for the connection of communication modules (may only be removed for connecting communication modules) |
| (3) Faston earthing terminal 6.3 mm   | (20) Switch for RUN/STOP operation:<br>With the RUN/STOP switch the execution of the user program is started or stopped.           |
| (4) ARCNET interface (BNC connector)  | (21) LED displays for CS31 system bus  |
| (5) PROFIBUS-DP interface (SUB-D, 9-pole)   | BA LED green Bus active  |
| (6) Supply voltage connection 24 V DC   | BE LED red Bus error   |
| (7) Battery compartment   | RE LED red Remote unit error   |
| (8) 24 digital inputs in 3 groups   | SE LED red Serial unit error   |
| (9) 24 green LEDs for the digital inputs  | (22) LED displays for RUN and error class  |
| (10) 8 individually configurable analog inputs in one group 0...10 V, 0...5 V, $\pm 10$ V, $\pm 5$ V, 0...20 mA, 4...20 mA, Pt100 (2-wire or 3-wire), differential inputs, the analog inputs are also individually configurable as digital inputs | RUN LED green User progr. is running   |
| (11) 16 digital transistor outputs in two groups  | FK1 LED red Fatal error  |
| (12) 16 yellow LEDs for the digital outputs   | FK2 LED red Serious error  |
| (13) 8 digital inputs/outputs in one group  | FK3 LED red Light error  |
| (14) 8 yellow LEDs for the digital inputs/outputs   | (23) Other LED displays  |
| (15) 4 individually configurable analog outputs $\pm 10$ V, 0...20 mA, 4...20 mA in one group   | Over-load LED red Overload/short-circuit at an output  |
| (16) Serial interface COM1 (programming, MMC)   | Supply LED green Supply voltage available  |
| (17) Serial interface COM2 (programming, MMC)   | Battery LED red Batt. <b>not</b> effective   |
|   | (24) Insertable SmartMedia Card 07 MC 90 for operating system, user program and user data  |



### 2.2.3.1 Terminal assignment overview

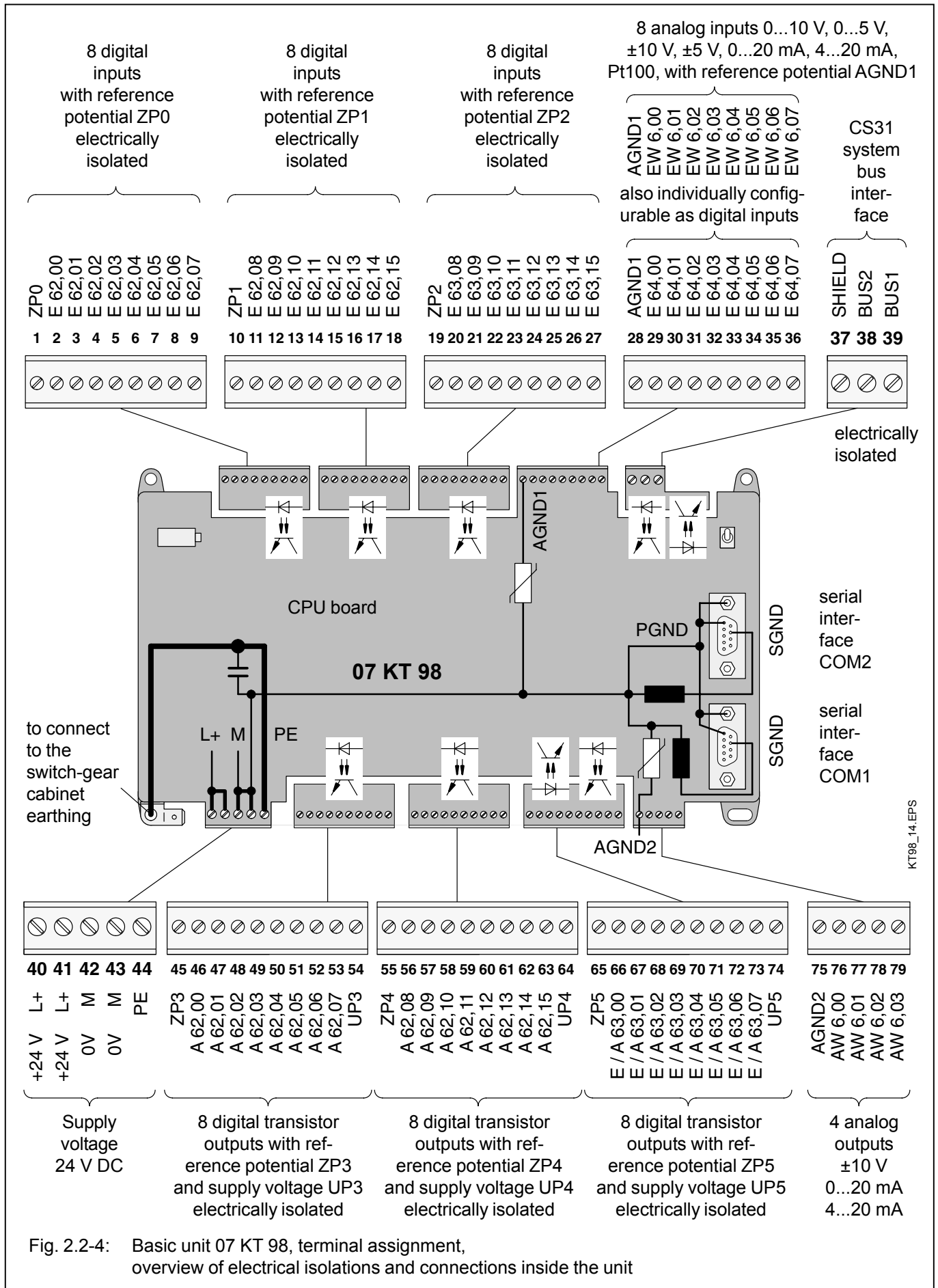

Fig. 2.2-4: Basic unit 07 KT 98, terminal assignment, overview of electrical isolations and connections inside the unit

## 2.2.4 Electrical connection

### 2.2.4.1 Application example for input and output wiring

The following illustration shows an application example in which different possibilities for wiring inputs and outputs are used.

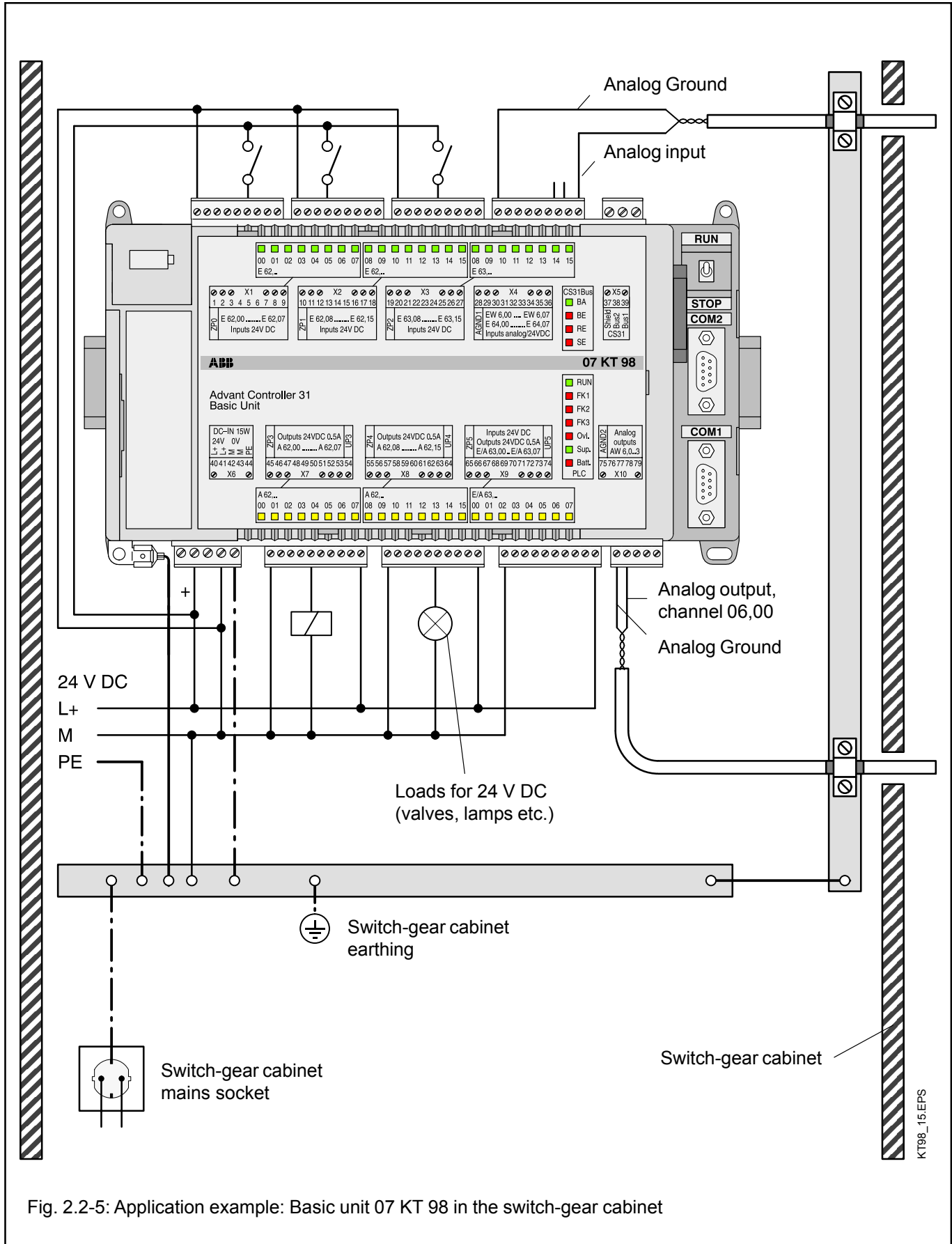

Fig. 2.2-5: Application example: Basic unit 07 KT 98 in the switch-gear cabinet

Please observe in particular:

- The earthing measures
- The handling of the electrically isolated input groups
- The handling of the electrically isolated output groups
- The connection of shielded analog cables
- The earthing of the switch-gear cabinet mains socket

### 2.2.4.2 Connection of the supply voltage

The 24 V DC supply voltage is connected via a 5-pole detachable screw-type terminal block.

**Attention: Plug and unplug terminal block only with power is off!**

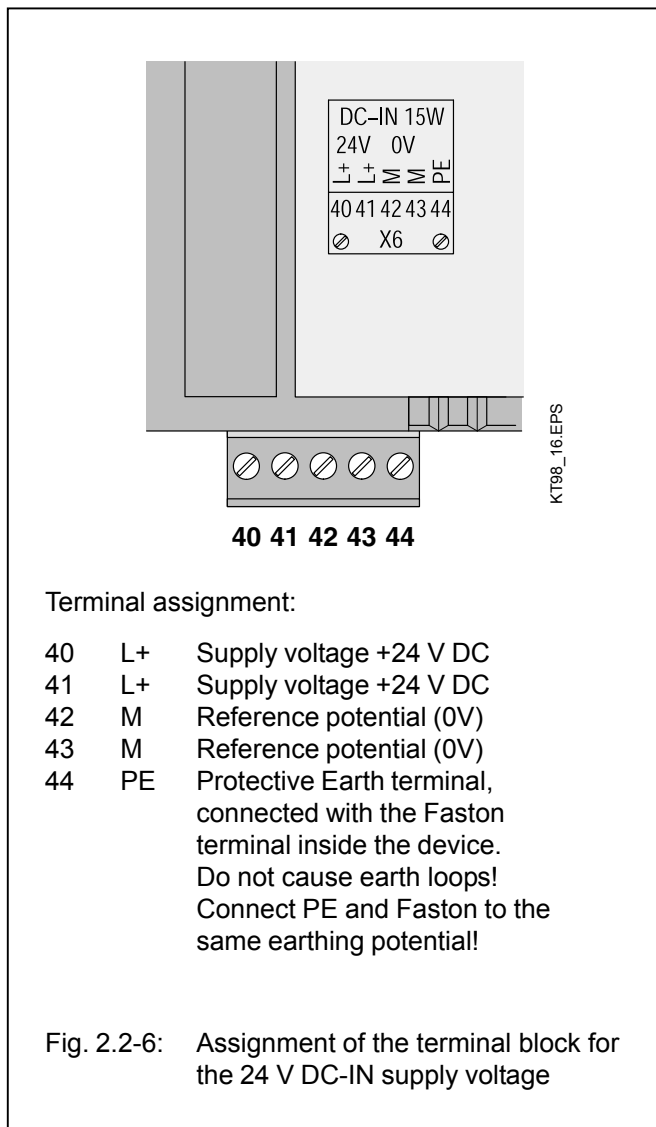

The terminals 40 and 41 (L+) as well as 42 and 43 (M) are connected to each other via the printed circuit board. If the power supply is looped through, these two connections must not be burdened with currents higher than **4 A**.

Please take also into consideration that supply voltages which are looped through are disconnected for the following devices when the plug is withdrawn.

If higher currents are to be conducted without interruption possibility, the two wires for M have to be connected under the same terminal. The same applies for L+.

### 2.2.4.3 Connection for the CS31 system bus

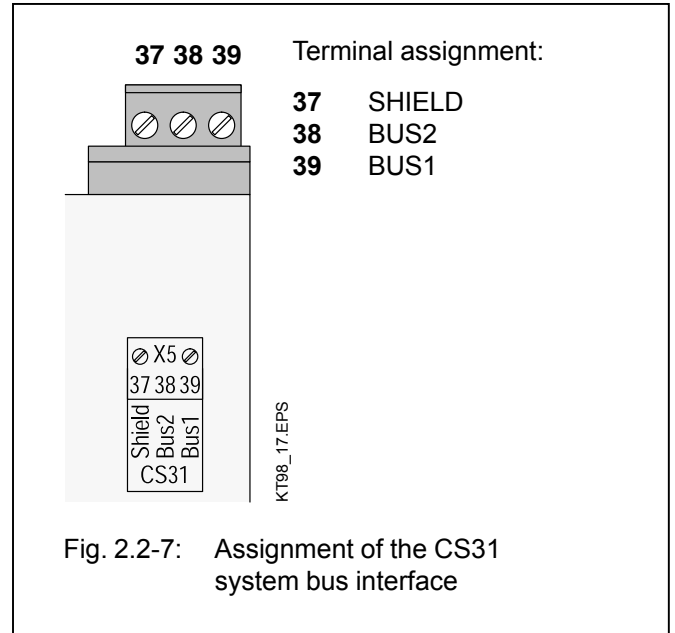

The connection to the CS31 system bus is made by means of a 3-pole detachable terminal block. Please observe:

- All of the AC31 devices, no matter whether they are master or slave devices, are connected with twisted-pair bus line as follows:
  - One core of the bus line is looped through via the BUS1 terminals of all devices to be connected to the CS31 system bus.
  - The other core of the bus line is looped through via the BUS2 terminals of all devices to be connected to the CS31 system bus.
- If the basic unit 07 KT 98 is located at the beginning or at the end of the bus line, the bus terminating resistor (120 Ω) has to be connected additionally between the BUS1 and BUS2 terminals.
- The shield of the twisted-pair bus line is looped through via the SHIELD terminals of all the devices to be connected to the CS31 system bus.
- The handling of the CS31 system bus is described in detail in volume 2, System data.

### 2.2.4.4 Connection of the digital inputs

The following figure shows the assignment of the 24 digital inputs.

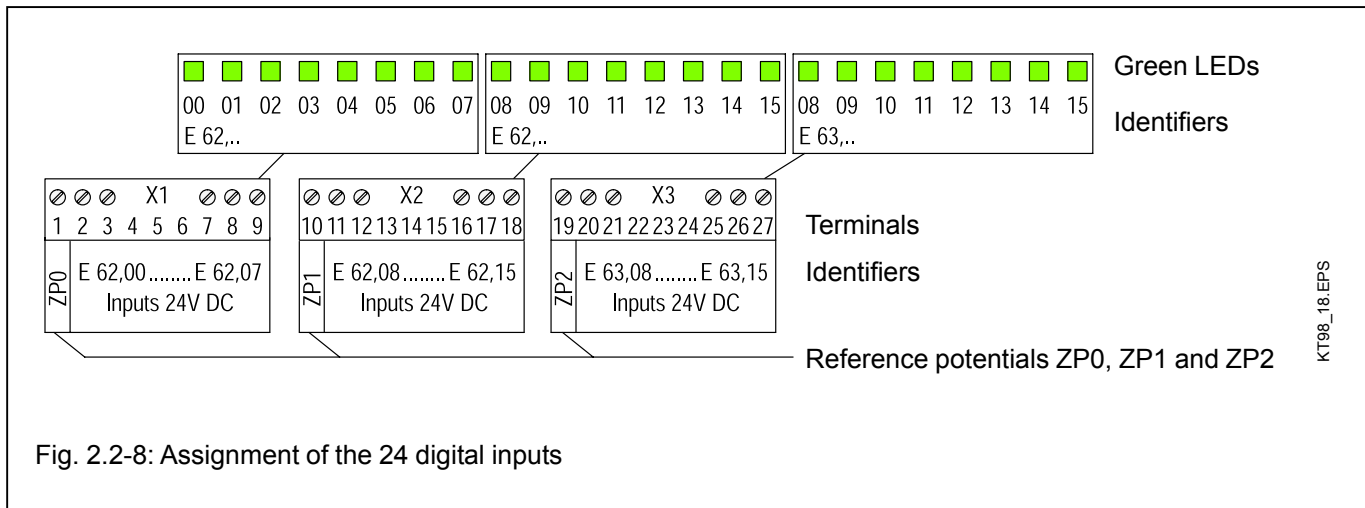

#### Features:

- The 24 digital inputs are arranged in three groups of 8 inputs each.
- The three groups E 62,00...E 62,07, E 62,08...E 62,15 and E 63,08...E 63,15 are electrically isolated from each other.
- The inputs use 24V signals in positive logic (1 = +24 V).
- The signal delay of the inputs is configurable to 7 ms (default) or 1 ms (see "System technology").
- The circuit configuration of the first group of the digital inputs is shown as an example in the following.

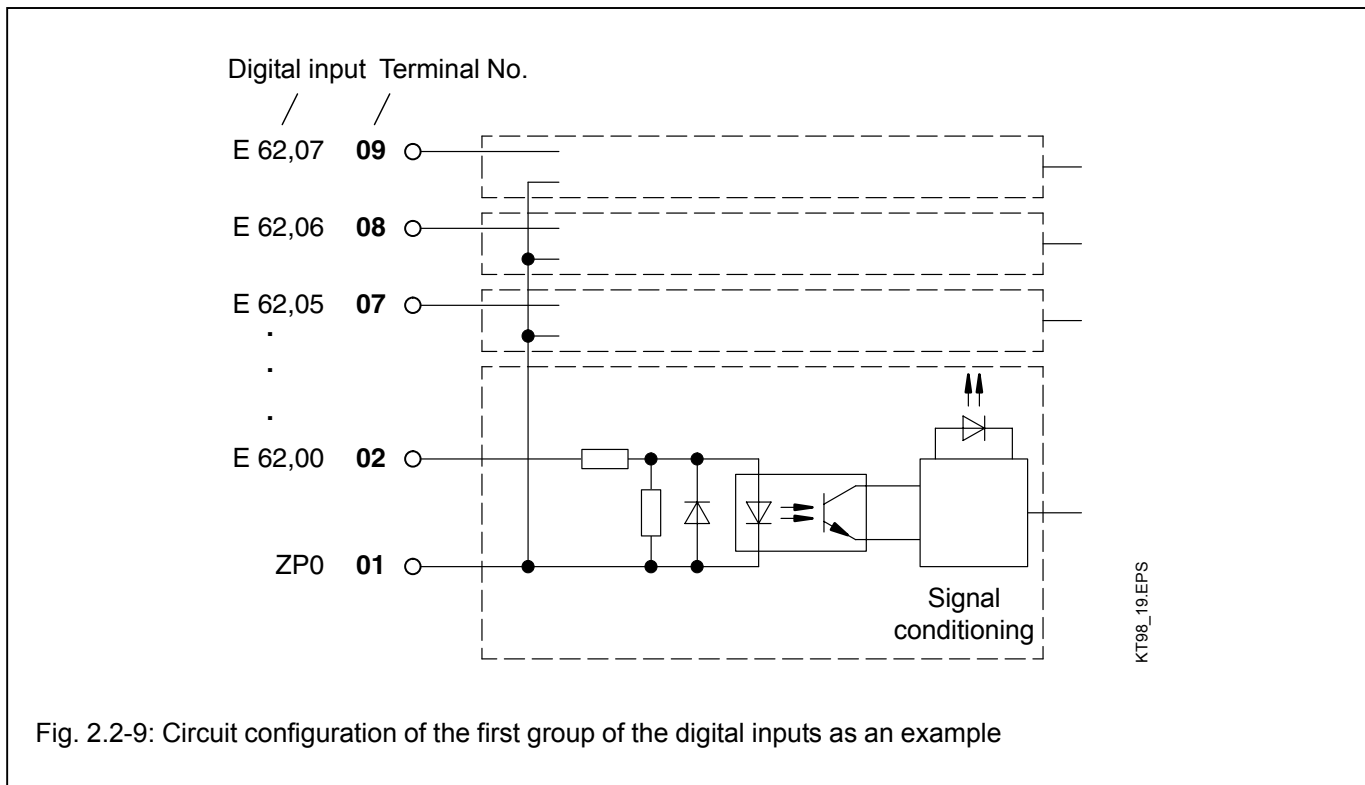

### 2.2.4.5 Connection of the digital outputs

The following figure shows the assignment of the 16 digital outputs.

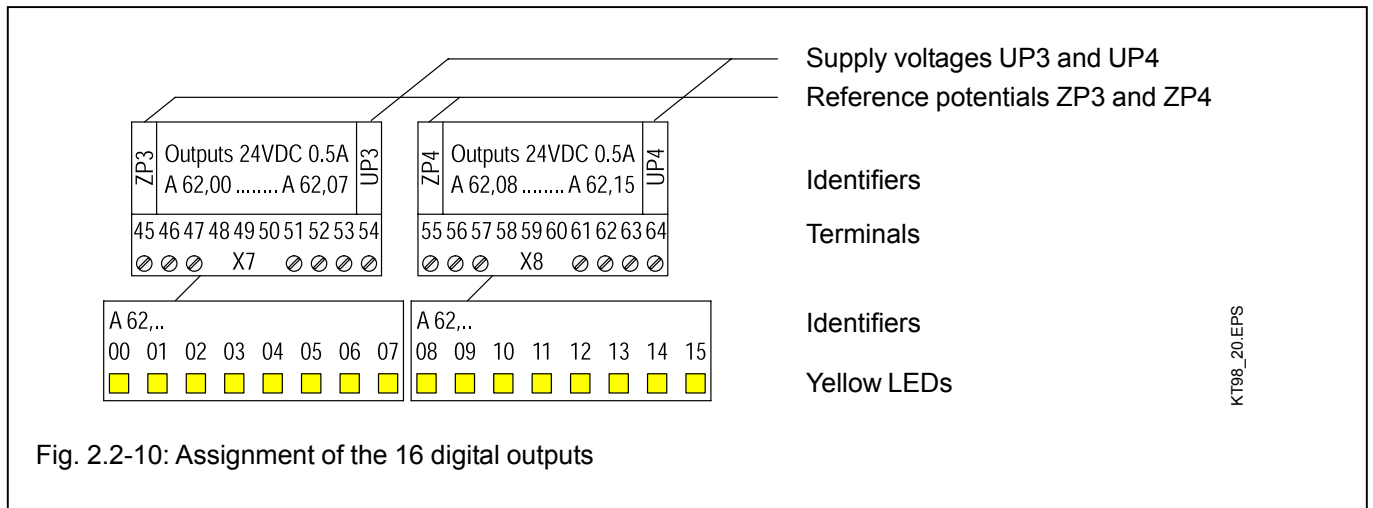

Fig. 2.2-10: Assignment of the 16 digital outputs

Features of the digital outputs:

- The 16 digital outputs are arranged in two groups of 8 outputs each.
- The two groups are electrically isolated from each other.
- The outputs can be loaded with a rated current of 500 mA.
- Each group as a whole is electrically isolated from the rest of the device.
- The outputs employ semiconductors and are short-circuit and overload-proof.
- The outputs are automatically switched off in case of overload or short-circuit.
- An overall error message indicates whether a short-circuit or an overload has occurred on a output group.
- The overload is displayed by the red LED Ovl. and via error flags in the PLC.
- The red LED Ovl. goes out when the overloaded output is switched on again automatically.
- The outputs are safe against reverse polarity and forced supply of 24 V DC.

## Circuit configuration of the digital outputs

The following figure shows the circuit configuration of the digital outputs of the first group as an example.

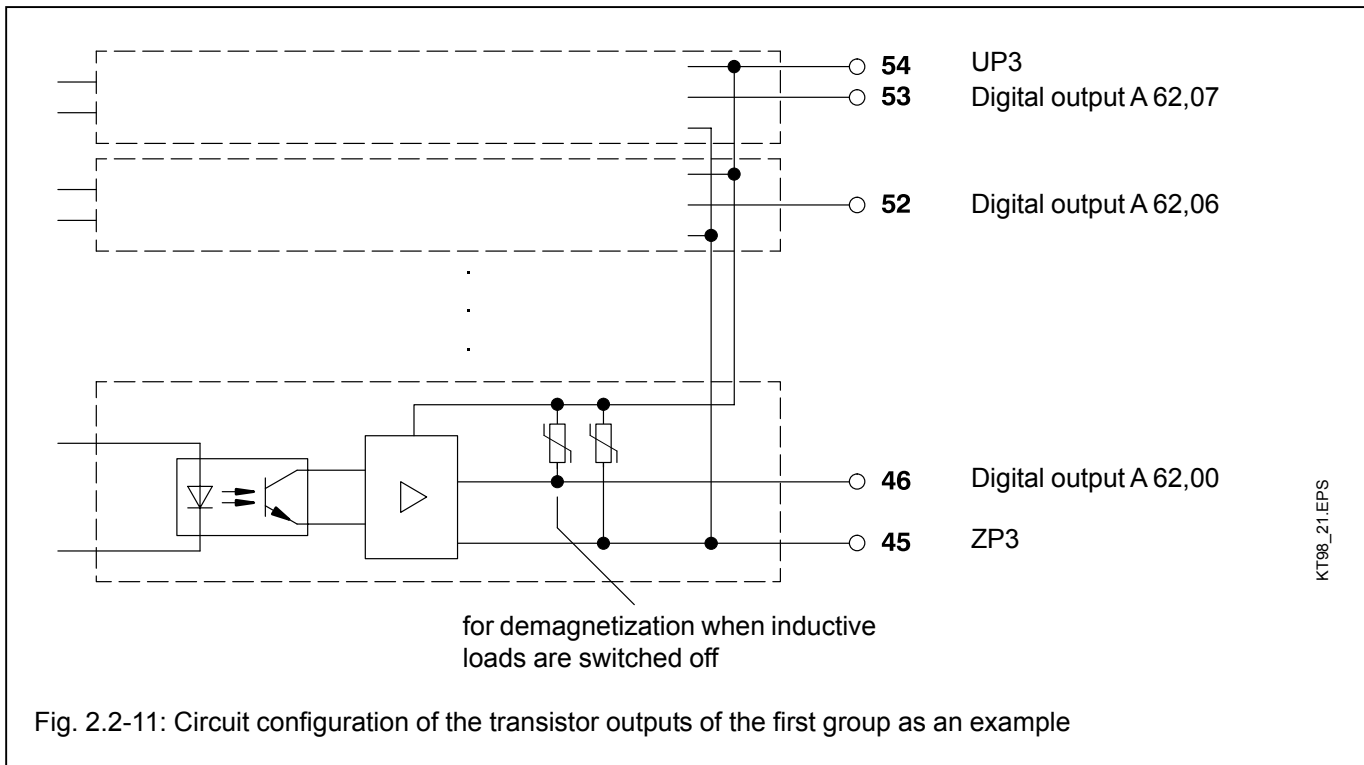

### 2.2.4.6 Connection of the digital inputs/outputs

The following figure shows the assignment of the 8 digital inputs/outputs.

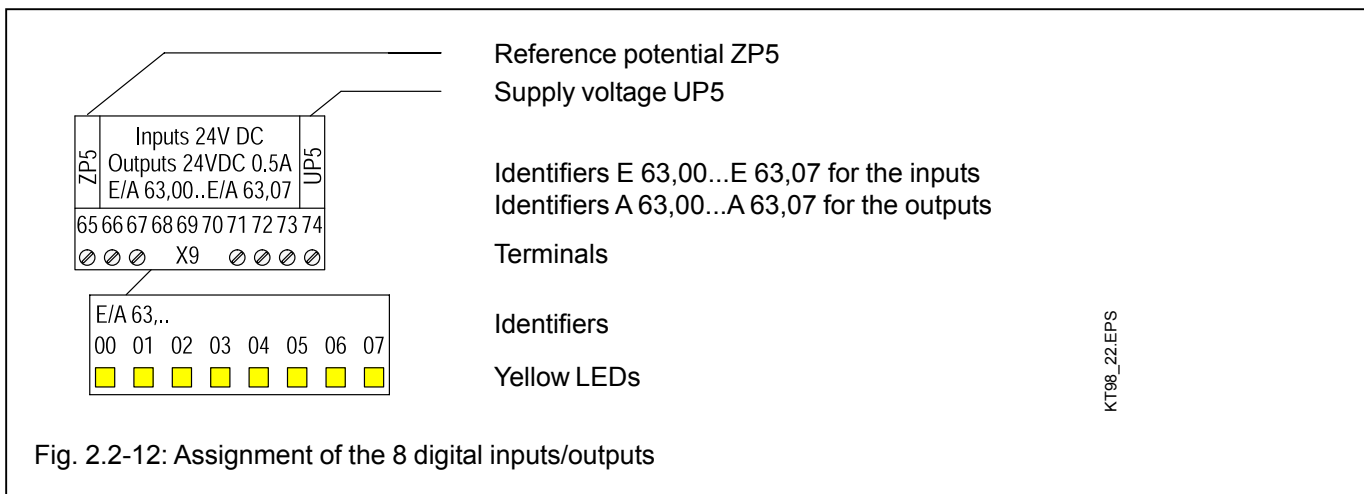

Features of the digital inputs/outputs:

- The 8 digital inputs/outputs are arranged in one group.
- The group as a whole is electrically isolated from the rest of the device.
- The inputs/outputs can be used individually as input, output or re-readable output.
- If the terminals are used as digital inputs, the input signal delay can be configured to 7 ms (default) or to 1 ms (see "System technology").
- If the terminals are used as digital outputs, the output signals "1" are individually monitored by the re-readable input. If the output status is wrong, an overall error message is generated for the involved output group. The error is displayed by the red LED Ovl. and by error flags of the PLC then. The error could have been caused by overload, short-circuit or missing supply voltage UP5/ZP5. The technical specifications of the outputs are the same as with the other digital outputs.

## Circuit configuration of the digital inputs/outputs

The following figure shows one of the 8 inputs/outputs of the group as an example.

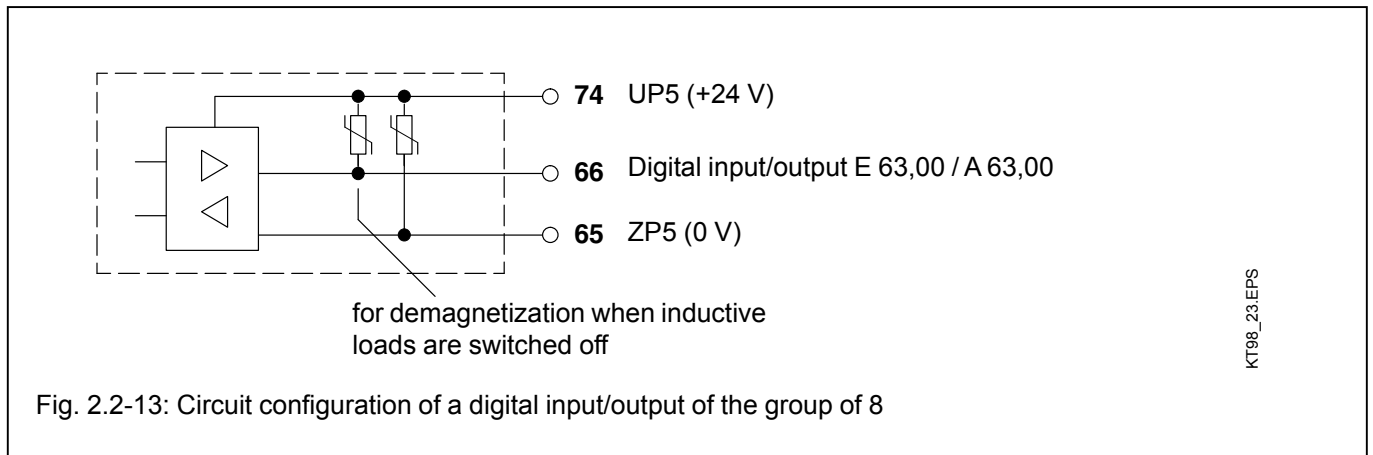

- The technical specifications of the inputs are the same with the other digital inputs, but **with the following exception:**

Caused by the direct electrical connection with the output, the varistor for demagnetization of inductive loads (see figure above) is also in effect at the input.

Therefore, the voltage difference between UP5 and the input signal must not be greater than the limit voltage of the varistor.

The limit voltage of the varistor is ca. 36 V. This means, that if UP5 = 24 V, the input signal voltage must be between -12 V and +30 V. If UP5 = 30 V, the input voltage has to be within -6 V and +30 V.

If all of the 8 channels of the group are used as inputs, and if in addition the UP5 terminal is left unconnected, no restrictions exist for the inputs. The input signal voltages then may be within -30 V and +30 V.

There is no restriction for the input/output group concerning its safety against reversed polarity.

### 2.2.4.7 Connection of the 8 configurable analog inputs

The following figure shows the assignment of the 8 analog inputs.

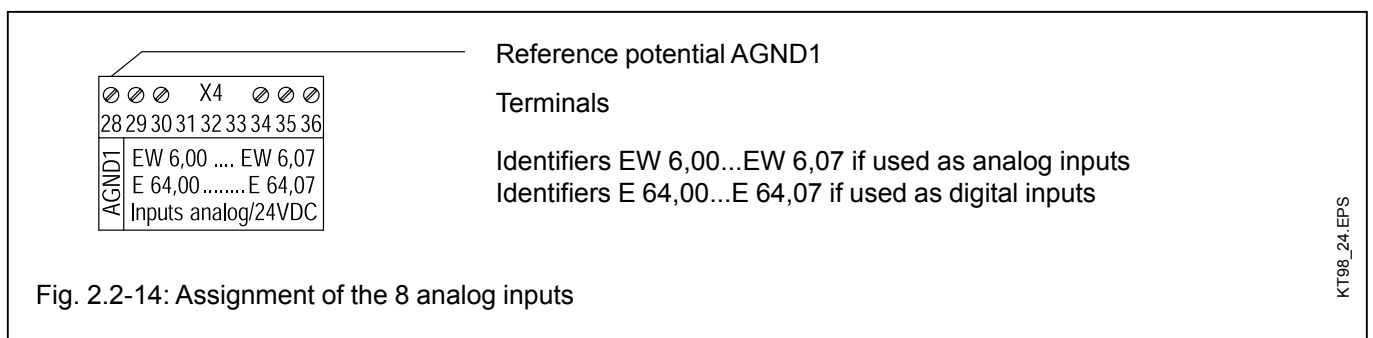

Features of the analog inputs:

- The 8 analog inputs are **not** electrically isolated.
- Resolution in the PLC system: The measured values are converted with a resolution of 12 bits, i.e. 11 bits plus sign for voltage and 12 bits without sign for currents. The ranges 0...5 V and  $\pm 5$  V are converted with 10 bits plus sign.
- Analog signals are conducted in shielded cables (see Fig. 2.2-5).

- The analog inputs can be used individually in a lot of different operating modes (even as digital inputs). The operating modes are configurable.
- In order to make sure, that unused input channels have a defined 0V level, they may be shorted to AGND.

In the following, some application examples are shown for analog sensors.

**Measuring ranges  $\pm 10\text{ V}$  /  $\pm 5\text{ V}$  /  $0\text{...}10\text{ V}$  /  $0\text{...}5\text{ V}$**

Input voltages which exceed the measuring range cause an overflow error message. If the measured value is below the range, an underflow error message is generated.

The input impedance is  $> 100\text{ k}\Omega$ .

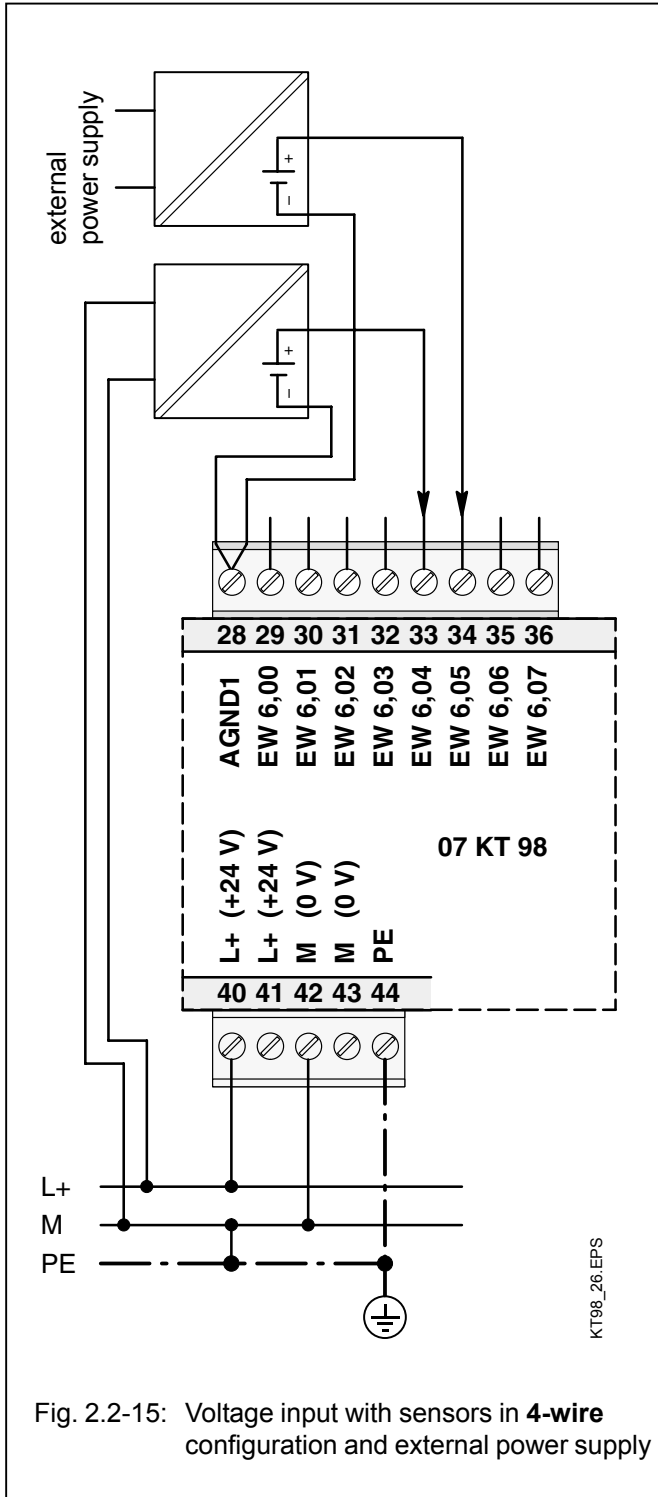

Fig. 2.2-15: Voltage input with sensors in **4-wire** configuration and external power supply

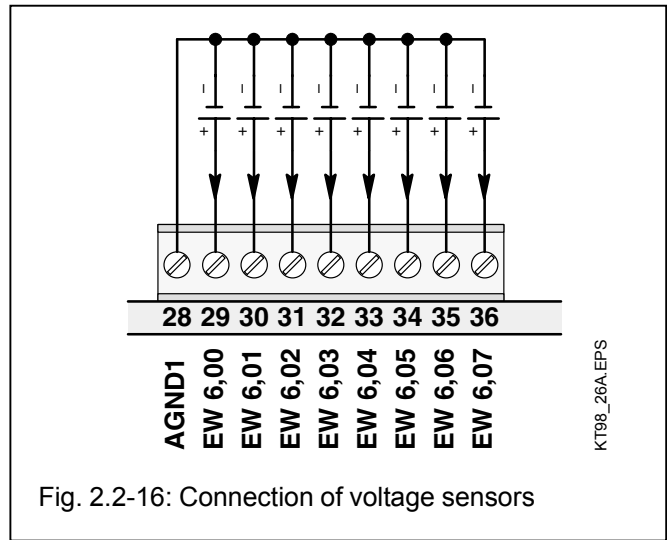

Fig. 2.2-16: Connection of voltage sensors

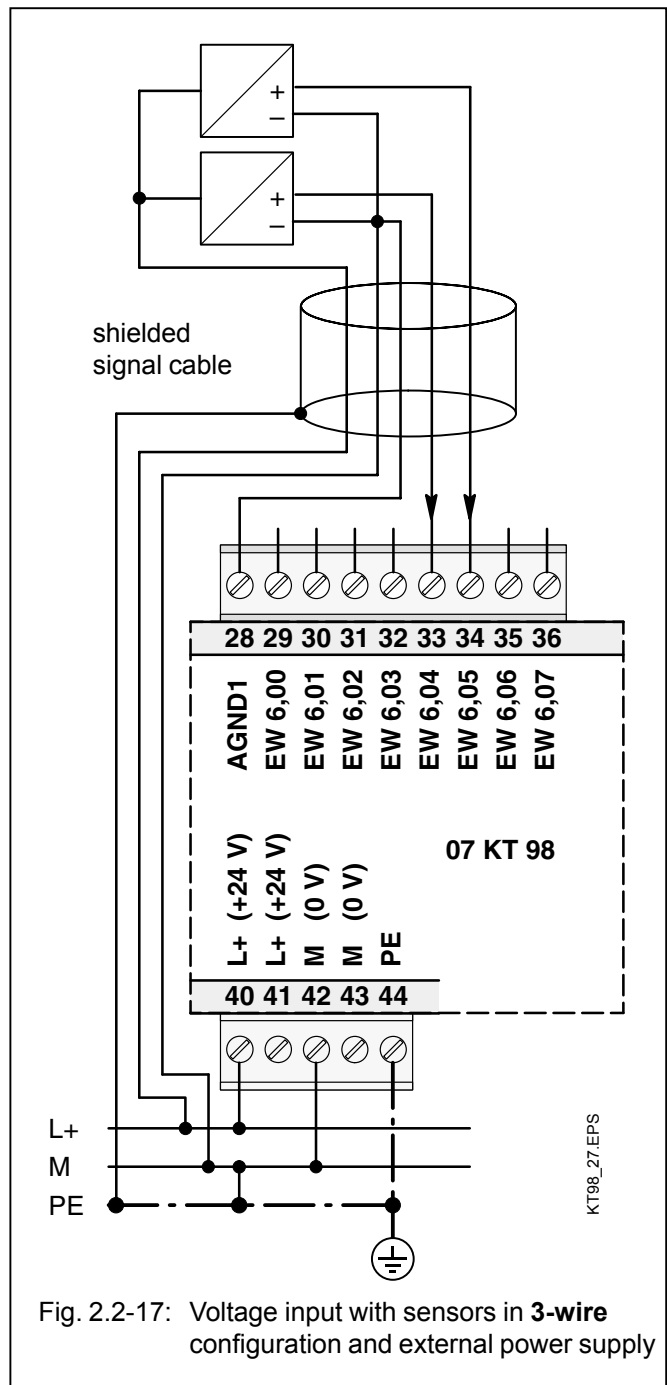

Fig. 2.2-17: Voltage input with sensors in **3-wire** configuration and external power supply



**Measuring range 4...20 mA  
(passive-type 2-pole sensors)**

Input currents which exceed the measuring range cause an overflow error message. If the measured value is below the range, an underflow error message is generated.

The input impedance is ca. 330 Ω. The current input has a self-protecting mechanism. If the input current gets too high, the shunt is switched off and the value for range overflow is generated. About every second, the unit tries to switch on the shunt again. In this way the correct measurement will succeed after the current has reached a normal value again.

The trigger of the self-protecting mechanism is displayed by the red LED Ovl. as long as the overload is present. In the PLC system an error message is then stored (FK4, error number 4).

The open-circuit monitoring begins below ca. 3 mA. The value of the range underflow is stored. If the open-circuit monitoring is configured, the open-circuit event is displayed by the red LED Ovl. as long as it is present. In the PLC system an error message is stored (FK4, error number 9).

The following figure shows the connection of **2-pole passive-type** analog sensors 4...20 mA.

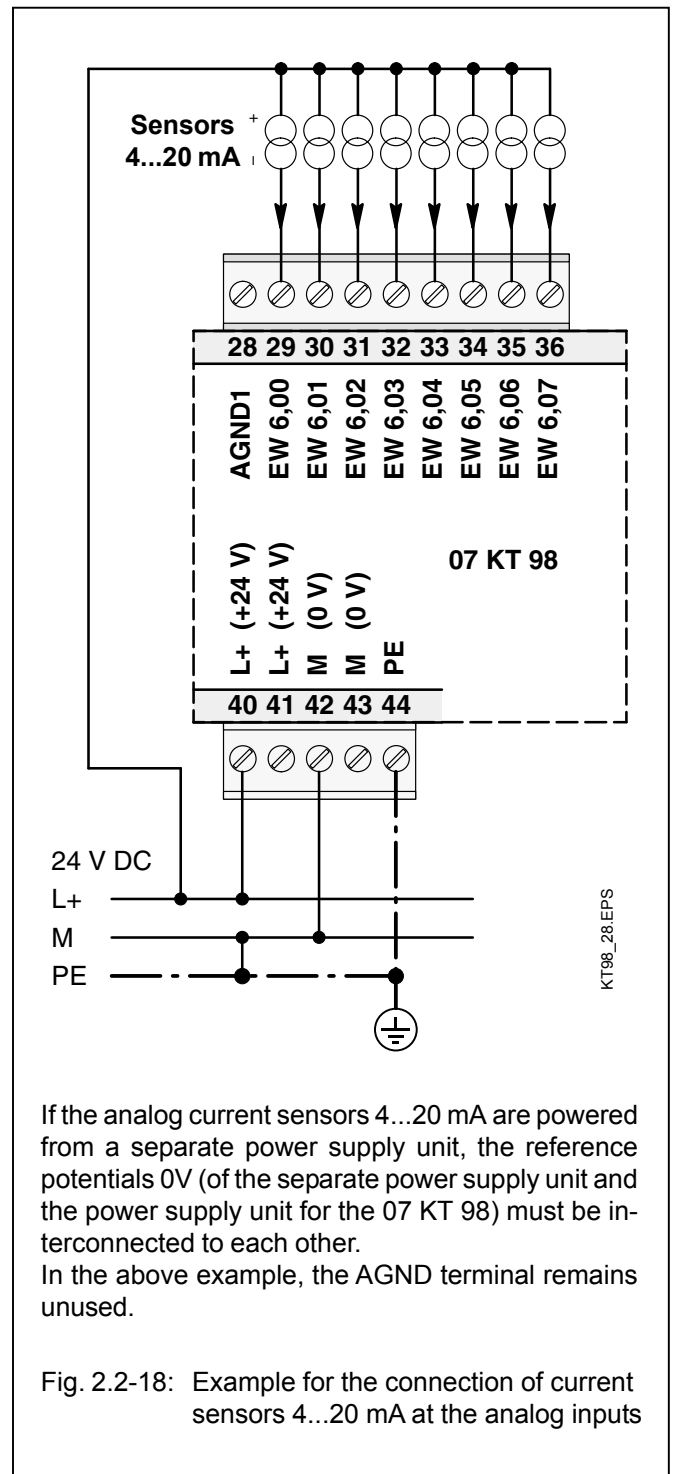

If the analog current sensors 4...20 mA are powered from a separate power supply unit, the reference potentials 0V (of the separate power supply unit and the power supply unit for the 07 KT 98) must be interconnected to each other. In the above example, the AGND terminal remains unused.

Fig. 2.2-18: Example for the connection of current sensors 4...20 mA at the analog inputs

**Measuring range 0...20 mA  
(active-type sensors with external supply voltage)**

Input currents which exceed the measuring range cause an overflow error message. If the measured value is below the range, an underflow error message is generated.

The input impedance is ca. 330 Ω. The current input has a self-protecting mechanism. If the input current gets too high, the shunt is switched off and the value for range overflow is generated. About every second, the unit tries to switch on the shunt again. In this way the correct measurement will succeed after the current has reached a normal value again.

The trigger of the self-protecting mechanism is displayed by the red LED Ovl as long as the overload is present. In the PLC system an error message is then stored (FK4, error number 4).

The following figure shows the connection of a 3-wire sensor powered by 24 V DC **and** of a 2-pole sensor powered electrically isolated. Both sensors work as **active current sources** 0...20 mA.

**It has to be taken into consideration, that in this application the M terminal of the basic unit is the reference potential. AGND1 is not dimensioned for carrying the sum of the sensor currents.**

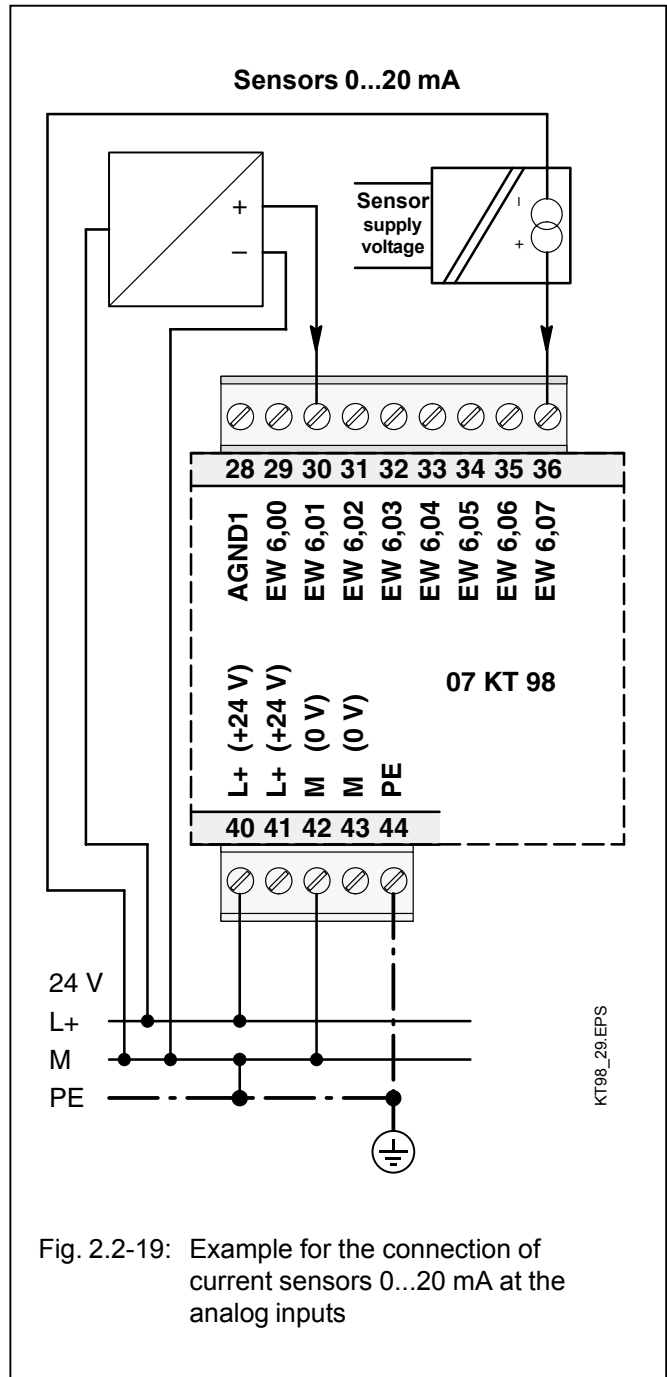

Fig. 2.2-19: Example for the connection of current sensors 0...20 mA at the analog inputs

## Measuring ranges $\pm 10\text{ V}$ / $\pm 5\text{ V}$ / $0\text{...}10\text{ V}$ / $0\text{...}5\text{ V}$ as differential inputs

Differential inputs are very useful, if analog sensors are used which are remotely non-isolated (e.g. the minus terminal is remotely earthed).

Since the earthing potential is not exactly the same as AGND1, it has to be measured bipolar in order to compensate measuring errors. Additionally, in case of single-pole configuration, AGND1 would be connected directly to the remote earth potential. This would cause inadmissible (and possibly dangerous) earthing loops.

In all configurations using **differential inputs** two adjacent analog inputs belong together (e.g. EW 6,00 and EW 6,01).

The measured value is calculated by subtraction. The value of the channel with the lower address is subtracted from the value of the channel with the higher address.

The converted measured value is available on the odd address (e.g. EW 6,01).

### Important:

The common mode input voltage range equals the measuring range of the single channel. I.e. that the signals, related to AGND, at the two involved inputs must not exceed this measuring range.

Input voltages which exceed the measuring range cause an overflow error message. If the measured value is below the range, an underflow error message is generated.

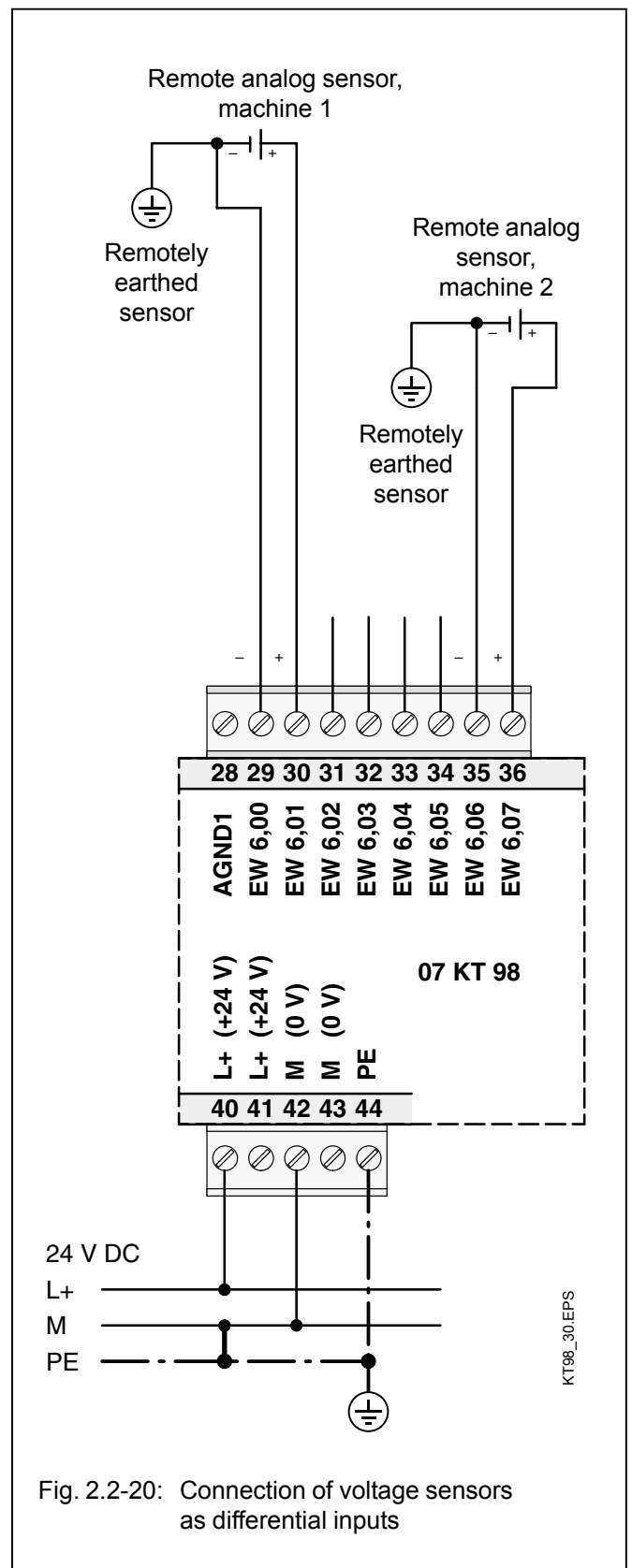
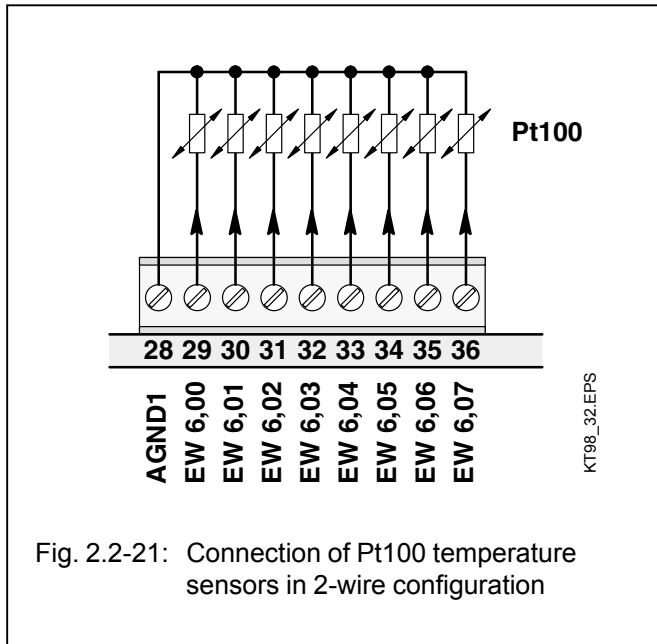

Fig. 2.2-20: Connection of voltage sensors as differential inputs

## Measuring ranges $-50^{\circ}\text{C} \dots +400^{\circ}\text{C}$ and $-50^{\circ}\text{C} \dots +70^{\circ}\text{C}$ with Pt100 as temperature sensor in 2-wire configuration

When resistance thermometers are used, a constant current must flow through the measuring resistor in order to create the necessary voltage drop for the evaluation. For this purpose, the basic unit 07 KT 98 provides a constant current sink, which is multiplexed to the 8 analog channels.

The following figure shows the connection of Pt100 resistance thermometers in **2-wire configuration**.



Depending on the configured operating mode, the measured value is assigned linearly as follows:

Range	assigned numerical value range
$-50\text{ C} \dots 400^{\circ}\text{C}$	$-1022 \dots +8190$ (FC02 <sub>H</sub> ...1FFE <sub>H</sub> )
$-50\text{ C} \dots 70^{\circ}\text{C}$	$-1022 \dots +1433$ (FC02 <sub>H</sub> ...0599 <sub>H</sub> )

The basic unit linearizes the Pt100 characteristic.

Temperatures which exceed the measuring range cause an overflow error message. If the measured value is below the range, an underflow error message is generated.

A detected open-circuit causes an overflow error message. If the sensor is short-circuited, an underflow error message is generated.

If the open-circuit or short-circuit monitoring is configured, the detected error is displayed by the red LED Ovl as long as it is present. In the PLC system an error message is stored (FK4, error number 9).

In order to avoid error messages with unused analog inputs, it is useful, **not** to configure this channels for Pt100.

## Measuring ranges $-50^{\circ}\text{C} \dots +400^{\circ}\text{C}$ and $-50^{\circ}\text{C} \dots +70^{\circ}\text{C}$ with Pt100 as temperature sensor in 3-wire configuration

The following figure shows the connection of Pt100 resistance thermometers in **3-wire configuration**.

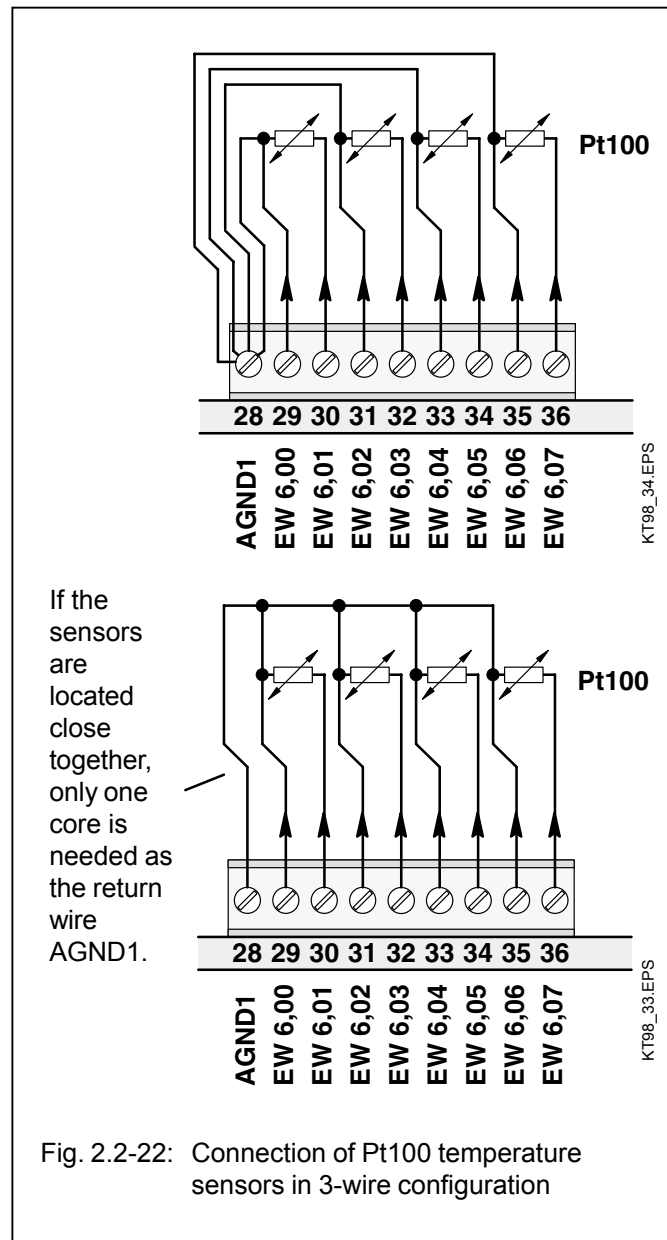

In the operating mode "**Pt100 in 3-wire configuration**" two adjacent analog inputs belong together (e.g. EW 6,00 and EW 6,01).

For configuration, both inputs must be configured to the desired operating mode.

The constant current of the one channel flows through the Pt100 resistance sensor, the constant current of the other channel through one of the wires.

The basic unit calculates the measuring value from the two voltage drops and stores it under the odd address (e.g. EW 6,01).

In order to avoid measurement errors, it is absolutely necessary, to lead the cores to the Pt100 sensors in the same cable. The cores must have the same cross section. Per channel, a twisted pair is used (for the two terminals of the Pt100 sensors) plus a single core (half of a twisted pair) for the connection to AGND1.

Depending on the configured operating mode, the measured value is assigned linearly as follows:

Range	assigned numerical value range
-50 C...400°C	-1022...+8190 (FC02 <sub>H</sub> ...1FFE <sub>H</sub> )
-50 C...70°C	-1022...+1433 (FC02 <sub>H</sub> ...0599 <sub>H</sub> )

The basic unit linearizes the Pt100 characteristic.

Temperatures which exceed the measuring range cause an overflow error message. If the measured value is below the range, an underflow error message is generated.

A detected open-circuit causes an overflow error message. If the sensor is short-circuited, an underflow error message is generated.

If the open-circuit or short-circuit monitoring is configured, the detected error is displayed by the red LED Ovl as long as it is present. In the PLC system an error message is stored (FK4, error number 9).

In order to avoid error messages with unused analog inputs, it is useful, **not** to configure this channels for Pt100.

### Use of analog inputs as digital inputs

Several (or all) analog inputs can be configured as digital inputs. When doing so, they evaluate input voltages higher than ca. +7 V as signal 1. The input impedance in this operating mode is about 4 kΩ. Terminal M is the reference potential.

The input signal delay is 7 ms. It cannot be configured. The inputs are not electrically isolated.

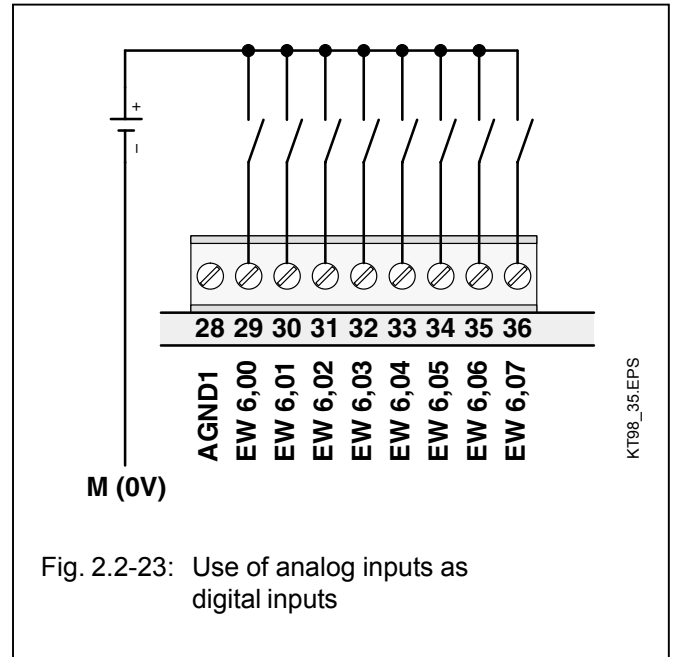

## 2.2.4.8 Connection of the 4 configurable analog outputs

The following figure shows the assignment of the 4 configurable analog outputs.

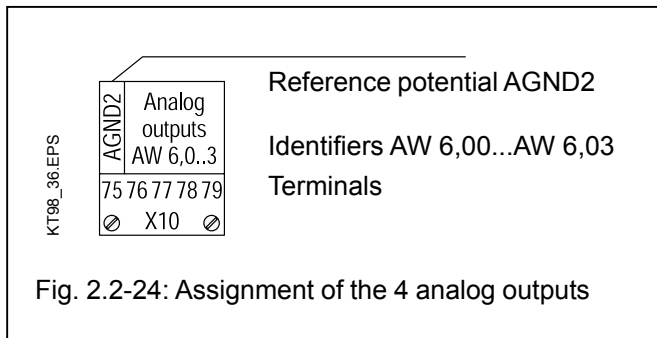

Features of the analog outputs:

- The 4 analog outputs are **not** electrically isolated..
- Resolution in the control system:  
All analog output values are converted with a resolution of 12 bits, i.e either 11 bits plus sign or 12 bits without sign.
- Analog signals are conducted in shielded cables (see Fig. 2.2-5).
- The analog outputs can be used individually in a lot of different operating modes. The operating modes can be configured with system constants.
- Unused output channels may be left unconnected.

In the following, an application example for an analog receiver is shown.

### Output ranges $\pm 10\text{ V}$ / $0\text{...}20\text{ mA}$ / $4\text{...}20\text{ mA}$

In case of voltage outputs the max. output current is  $\pm 3\text{ mA}$ . The output is short-circuit proof.

In case of current outputs, the range of permissible output load resistors is  $0\text{...}500\ \Omega$ . If in case of an error the outputs are switched off, this means the following:

Configuration  $\pm 10\text{ V}$        $0\text{ V}$   
 Configuration  $0\text{...}20\text{ mA}$      $0\text{ mA}$   
 Configuration  $4\text{...}20\text{ mA}$      $0\text{ mA}$ .

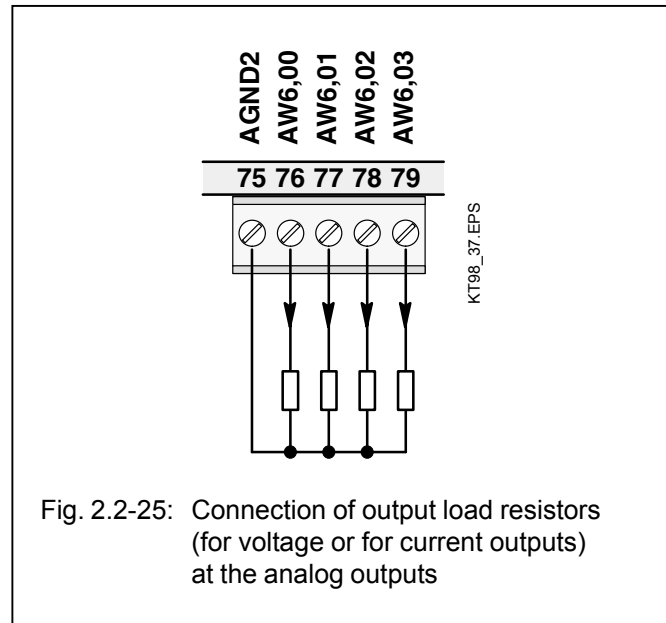

### Circuit configuration of an analog output

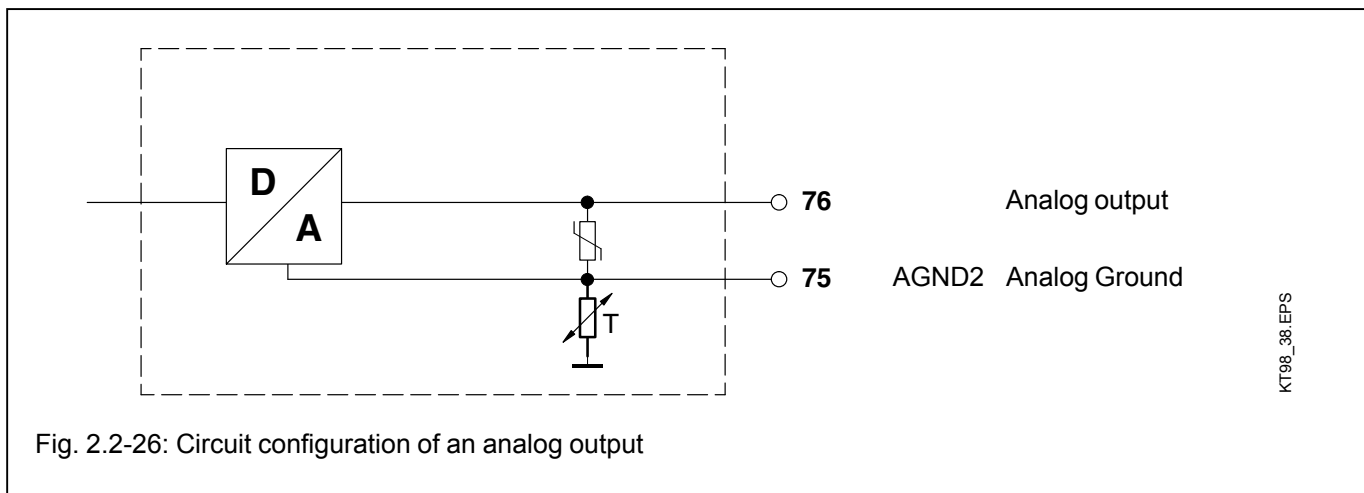

### 2.2.4.9 Battery and battery replacement

- The lithium battery 07 LE 90 can be inserted into the battery compartment in order to
  - backup data of user program in RAM
  - backup data of additionally in RAM contained information, e.g. flag statuses (RETAIN)
  - backup of time and date

The battery lifetime is typ. 5 years at 25°C. The battery lifetime is the time during which the device remains operable in order to backup data while the supply voltage of the basic unit is switched off. As long as there is a supply voltage available, there is no more load on the battery other than its own leakage current.

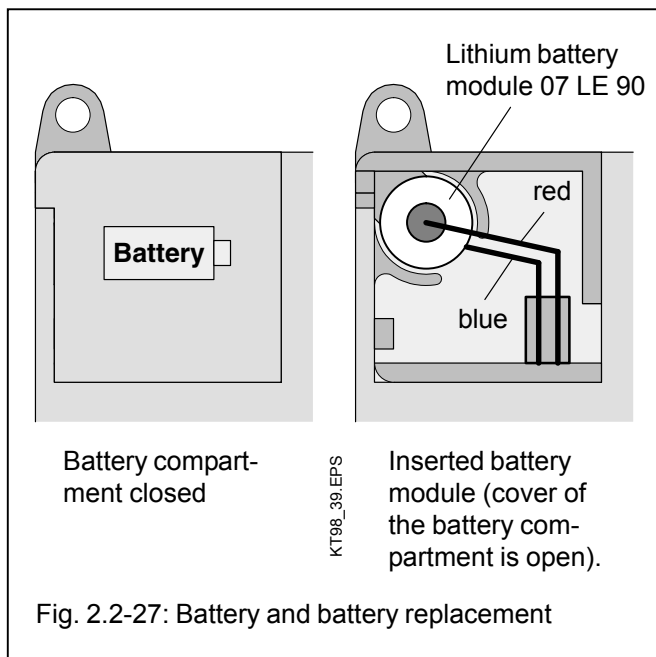

Fig. 2.2-27: Battery and battery replacement

The following handling notes have to be observed:

- Use only lithium batteries approved by ABB.
- Replace the battery by a new one at the end of its life.
- **Never short-circuit the battery!**  
There is danger of overheating and explosion. Avoid accidental short-circuits, therefore do not store batteries in metallic containers or boxes and do not bring them into contact with metallic surfaces.
- **Never try to charge a battery!**  
Danger of overheating and explosion.
- **Replace the battery only with the supply voltage switched on!**  
Otherwise you risk data being lost.
- **Dispose of battery environmentally consciously!**
- If no battery is inserted or if the battery is exhausted, the red LED "Battery" lights up.

### 2.2.4.10 Serial interface COM1

Interface standard: EIA RS-232

#### Assignment of the serial interface COM1

The serial interface COM1 has the following pin assignment:

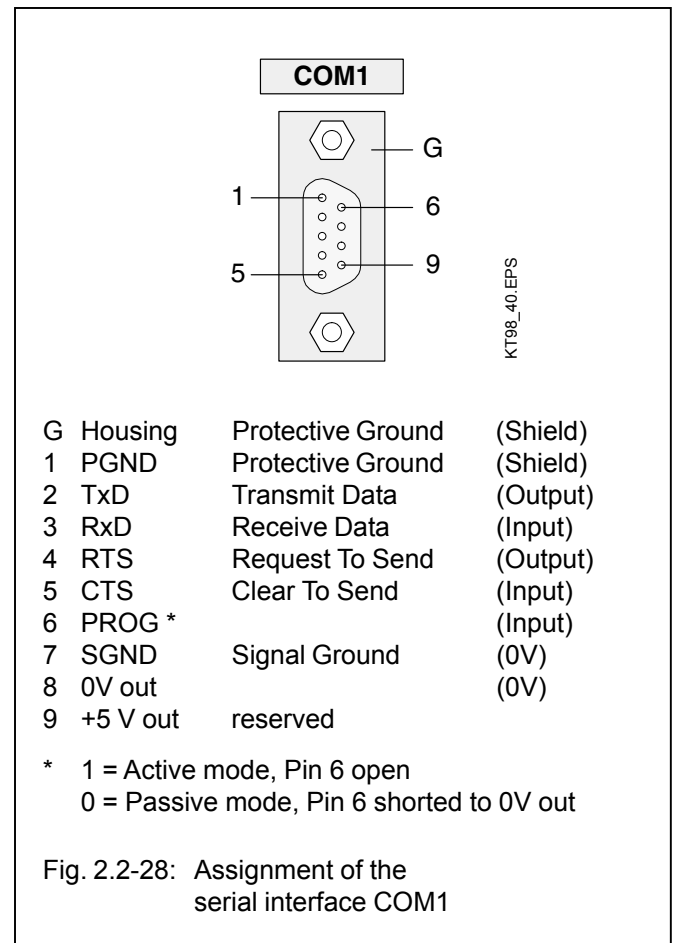

Fig. 2.2-28: Assignment of the serial interface COM1

### 2.2.4.11 Serial interface COM2

Interface standard: EIA RS-232

#### Assignment of the serial interface COM2

The serial interface COM2 has the following pin assignment:

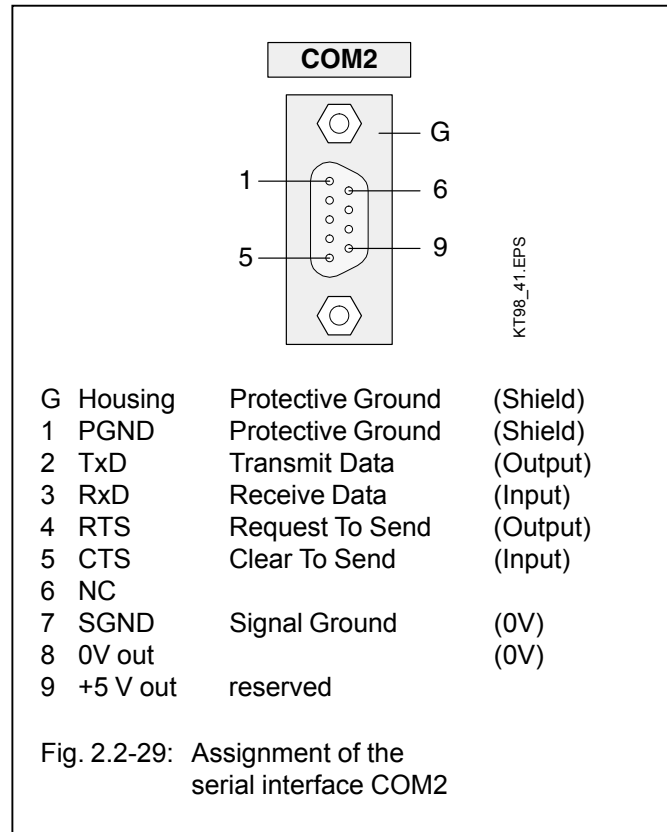

### 2.2.4.12 Networking interface

The 07 KT 98 basic unit is equipped with a special parallel interface. It is thus possible to network it with another bus system using an additional communication processor module.

The additional communication processor has its own housing. Both housings (of the 07 KT 98 and of the communication processor) are assembled by means of a snap-on connection.

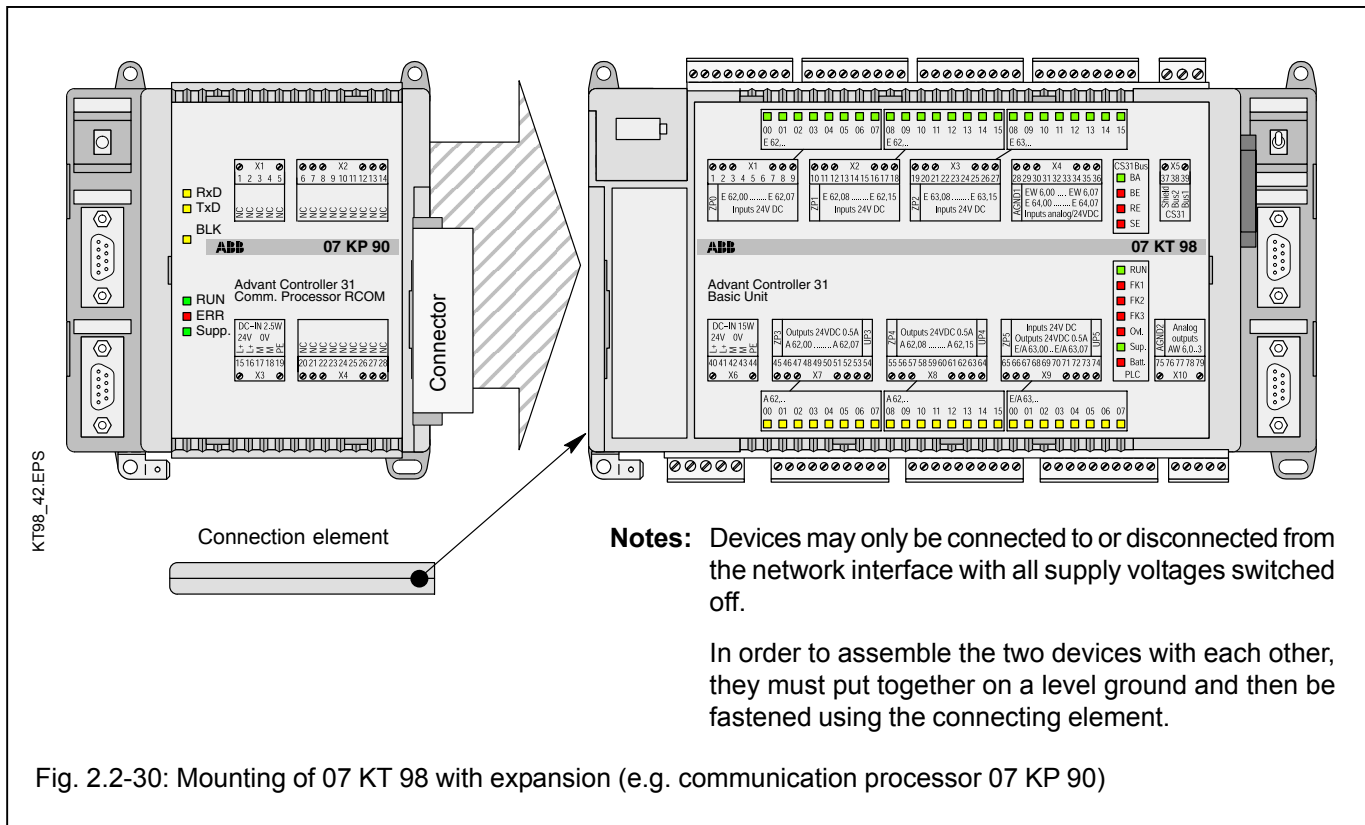



## 2.2.5 SmartMedia Card 07 MC 90

The SmartMedia Card serves for storing data up to 2 MB or 8 MB not being lost over an power OFF/ON cycle. It is used in the 07 KT 95...98 and 07 SL 97 basic units. It is recommended only to use ABB-proven SmartMedia Cards.

### Field of application

- Storing and loading of PLC programs
- Storing and loading of user data
- Loading of firmware updates

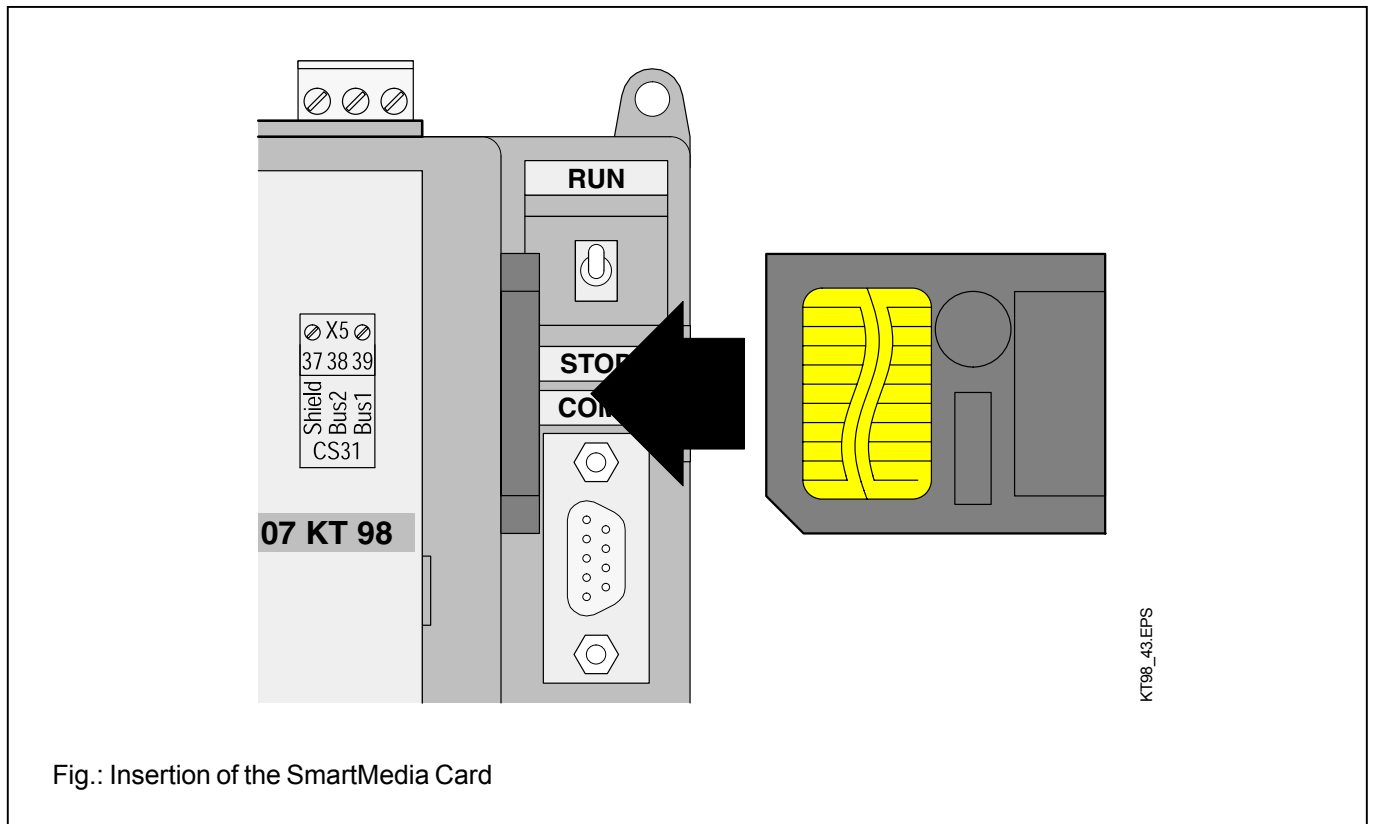

### Handling instructions

- The SmartMedia Card is inserted with the contact field visible (see the figure above).
- A SmartMedia Card, once initialized as user data memory, can no more be used as a user program card.
- The SmartMedia Card must be protected from
  - mechanical stress (e.g. do not bend)
  - electrostatic discharge
  - contact pollution (do not touch the contacts)

### Important note

SmartMedia Cards with a supply voltage of 3.3 V cannot be used with basic units of the versions R01xx. They also cannot be used with 07 SL 97 basic units (see Usability).

### Access

- Access within the PLC program is possible with function blocks, see documentation of the programming software.

### Usability

SmartMedia Card 07 MC 90 **5 V** GJR5 2526 00 **R0101** (supply voltage 5 V, usable with the basic units 07 SL 97, 07 KT 95 to 07 KT 98 **R 01xx** and **R02xx**, all firmware versions, memory capacity 2 MB)

SmartMedia Card 07 MC 90 **3,3 V** GJR5 2526 00 **R0201** (supply voltage 3.3 V, usable with the basic units 07 KT 95 to 07 KT 98 **R02xx** with firmware versions as of V5.0, memory capacity 8 MB)

### Technical data

Weight	2 g
Dimensions	45 x 37 x 0.7 mm

### Order numbers

07 MC 905 V	2 MB	GJR5 2526 00 <b>R0101</b>
07 MC 903.3 V	8 MB	GJR5 2526 00 <b>R0201</b>

## 2.2.6 High-speed counter

### Features

The high-speed counter used in the basic unit 07 KT 98 works independently of the user program and is therefore able to respond quickly to external signals. It can be used in seven different and configurable operating modes.

The desired operating mode is set in a system constant (see documentation part "System technology"). The configured operating mode is only activated during initialization (power-on, cold start, warm start). For all operating modes, the same function block **COUNTW** is used (see programming software).

Independent of the selected operating mode, the following features are valid:

- The pulses at the counter input or the evaluated signals at tracks A and B in case of connection of incremental position sensors are counted.
- The maximum counting frequency is 50 kHz.
- The counter uses the terminals 2 (E 62,00) and 3 (E 62,01) as fast inputs and, in one operating mode, also the output terminal 46 (A 62,00). In order to make all binary inputs and outputs available for other purposes than counting, it is possible, to disable the 07 KT 98's counting function.
- The counter can count upwards in all operating modes, in some modes it also can count downwards. The counting range is from  $-32768$  to  $+32767$  or from  $8000_H$  to  $7FFF_H$ .

## 2.2.7 Technical Data 07 KT 98

In general, the technical system data listed under "System data and system configuration" in chapter 1 of volume 2 of the Advant Controller 31 system description are valid. Additional data or data which are different from the system data are listed as follows.

### 2.2.7.1 General data

Number of digital inputs		24
Number of digital transistor outputs		16
Number of digital inputs/outputs		8
Number of analog inputs		8
Number of analog outputs		4
I/O expansion via CS31 system bus by up to		992 digital inputs 992 digital outputs 224 analog input channels 224 analog output channels max. 31 remote modules altogether
Number of serial interfaces		2 (for programming or connection to man-machine communication)
Number of parallel interfaces		1 special interface for connection of a communication processor (for networking with other bus systems)
Integrated memory	Flash EPROM SRAM DRAM	1 MB program + 128 kB user data 256 kB RETAIN 1 MB program + 1 MB user data
Resolution of the integrated real-time clock		1 second
Data of the integrated high-speed hardware counter		
Number of operating modes		7
Counting range		-32768...+32767 (16 bits signed integer)
Counting frequency		max. 50 kHz
Processing time, 65 % bits, 35 % words		typ. 0.07 ms/kB program
Number of software timers		any
delay time of the timers		1 ms...24.8 days
Number of up/down counter software blocks		any
Number of bit flags	in the addressable flag area	8192
Number of word flags	"	8192
Number of double word flags	"	1024
Number of step chains	"	256
Number of constants KW	"	1440
Number of constants KD	"	384
Indication of operating statuses and errors		60 LEDs altogether
Wiring method		removable screw-type terminal blocks
Power supply, CS31 system bus		max. 1 x 2.5 mm <sup>2</sup> or max. 2 x 1.5 mm <sup>2</sup> (see also page 2.2-9)
all other terminals		max. 1 x 1.5 mm <sup>2</sup>

### 2.2.7.2 Power supply

Rated supply voltage	24 V DC
Current consumption	max. 0.55 A
Protection against reversed polarity	yes

### 2.2.7.3 Lithium battery

Battery for backup of RAM contents

Battery module 07 LE 90

Lifetime at 25°C

typ. 5 years

### 2.2.7.4 Digital inputs

Number of channels per module

24

Distribution of channels into groups

3 groups of 8 channels each

Common reference potential

for group 1 (8 channels)

ZP0 (channels 62,00...62,07)

for group 2 (8 channels)

ZP1 (channels 62,08...62,15)

for group 3 (8 channels)

ZP2 (channels 63,08...63,15)

Electrical isolation

between the groups,  
between groups and other circuitry  
(see also Fig. 2.2–4)

Signal coupling of input signals

with optocoupler

Configuration possibilities of the inputs

Input signal delay

typ. 7 ms (configurable to 1 ms)

Channels E 62,00 and 62,01

configurable for the high-speed counter

Signalling of input statuses

one green LED per channel,  
the LEDs correspond functionally to the input signals

Input signal voltage

Signal 0

-30 V...+ 5 V

Signal 1

+13 V...+ 30 V

Input current per channel

Input voltage = +24 V

typ. 7.0 mA

Input voltage = + 5 V

> 0.2 mA

Input voltage = +13 V

> 2.0 mA

Input voltage = +30 V

< 9.0 mA

Max. cable length, unshielded

600 m

Max. cable length, shielded

1000 m

### 2.2.7.5 Digital outputs

Number of channels per module

16 transistor outputs

Distribution of channels into groups

2 groups of 8 channels each

Common supply voltage

for group 1

UP3 (channels 62,00...62,07)

for group 2

UP4 (channels 62,08...62,15)

Electrical isolation

between the groups,  
between groups and other circuitry  
(see also Fig. 2.2–4)

Signalling of output statuses

one yellow LED per channel,  
the LEDs correspond functionally to the output signals

Output current

Rated value

500 mA with UP3/4 = 24 V

Maximum value

625 mA with UP3/4 = 24 V + 25%

Leakage current with signal 0

< 0.5 mA

Demagnetization of inductive loads

internally with a varistor

Switching frequency with inductive loads

max. 0.5 Hz

Switching frequency with lamp loads

max. 11 Hz with max. 5 W

Max. cable length		400 m (pay attention to voltage drops)
Short-circuit proof / overload proof		yes
Protection of the outputs against reversed polarity		yes
Forcing of 24 V DC at the outputs possible		yes
Total load (via UP3 or UP4)		max. 4 A
<b>2.2.7.6 Digital inputs/outputs</b>		
Number of channels per module		8 inputs/outputs
Distribution of channels into groups		1 group with 8 channels
Common reference potential		ZP5 (channels E/A 63,00...E/A 63,07)
Common voltage supply		UP5 (channels E/A 63,00...E/A 63,07)
Electrical isolation		between the group and other circuitry (see Fig. 2.2-4)
Signal coupling of the input signals		with optocoupler
Configuration possibilities of the inputs		
Input signal delay, channels E 63,00...E 63,07		typ. 7 ms (configurable to 1 ms)
Signalling of input/output statuses		one yellow LED per channel, the LEDs correspond functionally to the I/O signals
Input signal voltage (if used as inputs)		for details see Fig. 2.2-13 as well as the chapter "Circuit configuration of the digital inputs/outputs"
Signal 0		-6 V...+ 5 V
Signal 1		+13 V...+ 30 V
Input current per channel		see Digital inputs
Output current / switching frequency / inductive loads		see Digital outputs
Max. cable length		see Digital inputs/outputs
<b>2.2.7.7 Analog inputs</b>		
Number of channels per module		8
Distribution of channels into groups		1 group with 8 channels
Common reference potential		
for group 1 (8 channels)		AGND1 (channels 06,00...06,07)
Electrical isolation		none (see also Fig. 2.2-4).
Max. permissible potential difference between		
Terminal M (minus pole of the power supply voltage)		
and terminal AGND (analog I/O minus pole)		± 1 V
Signalling of input statuses		none
Configuration possibilities (each channel), see 2.2.4.7		0...10 V, 0...5 V, ±10 V, ±5 V (also with differential signal) 0...20 mA, 4...20 mA Pt100 -50...+400°C and -50...+70°C (2-wire and 3-wire configuration) digital input
Input impedance per channel,	voltage input	> 100 kΩ
	current input	ca. 330 Ω
	digital input	ca. 4 kΩ

The current input has a self-protecting mechanism. If the input current gets too high, the shunt is switched off and the value for range overflow is generated. About every second, the unit tries to switch on the shunt again. In this way the correct measurement will succeed after the current has reached a normal value again.

Time constant of the input filter	470 µs with voltage, 100 µs with current
Conversion cycle of current and voltage channels	Each configured input channel (U, I, Pt100) increases the conversion cycle of the U/I channels by typ. 1 ms.
Conversion cycle (by filtering time) of Pt100 channels	Each configured input channel (U, I, Pt100) increases the conversion cycle of the Pt100 channels by typ. 50 ms.
Conversion cycle of unused input channels	Input channels configured as "unused" are skipped, i.e. they do not need any conversion time.

#### Examples for the conversion cycle

Example No.	1	2	3	4	5	6
Channels configured for U/I	1	8 *	-	-	2	4
Channels configured for Pt100	-	-	4	8	2	4
Channels configured as "unused"	7	-	4	-	4	-
Conversion cycle of U/I channels	1 ms	8 ms	-	-	4 ms	8 ms
Conversion cycle of Pt100 channels	-	-	200 ms	400 ms	200 ms	400 ms

#### \* Factory setting

Resolution in bits	ranges ±10 V, 0...10 V ranges ±5 V, 0...5 V ranges 0...20 mA, 4...20 mA range -50 °C...+70 °C range -50 °C...+400 °C	11 bits plus sign 10 bits plus sign 12 bits without sign 10 bits plus sign 11 bits plus sign
Resolution in mV, µA	range ±10 V range 0...10 V range 0...20 mA range 4...20 mA	ca. 5 mV ca. 5 mV ca. 5 µA ca. 4 µA
Relationship between input signal and hex code		$-100 \% \dots 0 \dots +100 \% = 8008_{\text{H}} \dots 0000_{\text{H}} \dots 7FF8_{\text{H}}$ (-32760...0...32760 decimal)
Conversion inaccuracy caused by non-linearity, temperature sensitivity, ageing, adjustment error on delivery and resolution: U, I Pt100		typ. 0.5 %, max. 1 % typ. 1 °C, max. 2 °C
Threshold, if analog input is configured as digital input		ca. 7 V
Max. cable length, 2-core shielded and cross section ≥ 0,5 mm <sup>2</sup>		100 m
<b>2.2.7.8 Analog outputs</b>		
Number of channels per module		4
Reference potential		AGND2 (channels 06,00...06,03)
Electrical isolation		none (see also Fig. 2.2-4).
Max. permissible potential difference between Terminal M (minus pole of the power supply voltage) and terminal AGND (analog I/O minus pole)		± 1 V

Signalling of output statuses	none
Output signal ranges (configurable)	-10 V...0...+10 V 0...20 mA 4...20 mA
Output load capability of the voltage outputs	max. ±3 mA
Resolution	12 bits
Resolution (1 LSB), range -10 V...0...+10 V	5 mV
Relationship between output signal and hex code	-100 %...0...+100 % = 8008 <sub>H</sub> ...0000 <sub>H</sub> ...7FF8 <sub>H</sub> (-32760...0...32760 decimal)
Conversion cycle for outputs	typ. 1 ms for each configured output channel
Conversion inaccuracy caused by non-linearity, temperature sensitivity, ageing, adjustment error on delivery and resolution	typ. 0.5 %, max. 1 %
Max. cable length, 2-core shielded and cross section ≥ 0,5 mm <sup>2</sup>	100 m

### 2.2.7.9 Connection of serial interfaces COM1 and COM2

Interface standard	EIA RS-232
Programming with 907 AC 1131	with IBM PC (or compatible)
Program modifications with 907 AC 1131	with IBM PC (or compatible)
Man-machine communication	yes, e.g. with an operating station
Electrical isolation	versus digital inputs and outputs, versus CS31 system bus interface (see also Fig. 2.2-4)
Potential differences	In order to avoid potential differences between the 07 KT 98 basic unit and the peripheral devices connected to the COM1/COM2 interfaces, these devices are supplied from the switch-gear cabinet socket (see also the earthing connections in Fig. 2.2-5).
Pin configuration and description of the COM1/COM2 interfaces	see chapters 2.2.4.10 and 2.2.4.11

### 2.2.7.10 Connection to the CS31 system bus

Interface standard	EIA RS-485
Connection as a Master PLC as a Slave PLC	yes, transmitting and receiving areas are configurable yes, see "System constants"
Setting of the CS31 module address	yes, by system constant, stored in Flash EPROM of the Slave PLC
Electrical isolation	versus supply voltage, inputs and outputs, versus interfaces COM1/COM2 (see also Fig. 2.2-4)
Terminal assignment and description of the CS31 bus interface	see chapter 2.2.4.3

### 2.2.7.11 LED displays

LEDs for indication of:

– Statuses of digital inputs	1 green LED per channel
– Statuses of digital outputs	1 yellow LED per channel
– Statuses of digital inputs/outputs	1 yellow LED per channel
– Power supply on	1 green LED
– Battery	1 red LED
– Program is running (RUN)	1 green LED
– Error classes (FK1, FK2, FK3)	1 red LED per error class
– CS31 system bus is running (BA)	1 green LED
– bus-specific errors (BE, RE, SE)	3 red LEDs
– Overload/short-circuit of digital outputs	1 red LED

### 2.2.7.12 High-speed hardware counter

Data of the integrated high-speed hardware counter:

Configurable	in 7 operating modes
Counting range	-32768...+32767 (16 bits)
Counting frequency	max. 50 kHz
Used inputs	E 62,00 and E 62,01
Used outputs	A 62,00





### 2.2.7.15 Ordering data

Basic unit 07 KT 98 R0120 (+ PROFIBUS-DP)	Order No. GJR5 2531 00 R0120
Basic unit 07 KT 98 R0220 (+ PROFIBUS-DP)	Order No. GJR5 2531 00 R0220
Basic unit 07 KT 98 R0160 (+ ARCNET)	Order No. GJR5 2531 00 R0160
Basic unit 07 KT 98 R0260 (+ ARCNET)	Order No. GJR5 2531 00 R0260
Basic unit 07 KT 98 R0162 (+ ARCNET + PROFIBUS-DP)	Order No. GJR5 2531 00 R0162
Basic unit 07 KT 98 R0262 (+ ARCNET + PROFIBUS-DP)	Order No. GJR5 2531 00 R0262
Basic unit 07 KT 98 R0268 (+ ARCNET + CANopen)	Order No. GJR5 2531 00 R0268
Basic unit 07 KT 98 R0270 (+ Ethernet)	Order No. GJR5 2531 00 R0270
Basic unit 07 KT 98 R0272 (+ Ethernet + PROFIBUS-DP)	Order No. GJR5 2531 00 R0272
Basic unit 07 KT 98 R0276 (+ Ethernet + ARCNET)	Order No. GJR5 2531 00 R0276
Basic unit 07 KT 98 R0277 (+ Ethernet + Ethernet)	Order No. GJR5 2531 00 R0277
Basic unit 07 KT 98 R0278 (+ Ethernet + CANopen)	Order No. GJR5 2531 00 R0278
Basic unit 07 KT 98 R0280 (+ CANopen)	Order No. GJR5 2531 00 R0280

#### Scope of delivery

Basic unit 07 KT 98  
1 5-pole terminal block (5.08 mm)  
1 3-pole terminal block (5.08 mm)  
3 10-pole terminal blocks (3.81 mm)  
4 9-pole terminal blocks (3.81 mm)  
1 5-pole terminal block (3.81 mm)

### Accessories

System cable 07 SK 90	Order No. GJR5 2502 00 R0001
System cable 07 SK 91	Order No. GJR5 2503 00 R0001
System cable 07 SK 92	Order No. GJR5 2504 00 R0001
Battery module 07 LE 90	Order No. GJR5 2507 00 R0001
SmartMedia Card 07 MC 90 5.0 V 2 MB	Order No. GJR5 2526 00 R0101
SmartMedia Card 07 MC 90 3.3 V 8 MB	Order No. GJR5 2526 00 R0201

### Further literature

System description ABB Procontic CS31 English	Order No. FPTN 4400 04 R2001
System description Advant Controller 31 English	Order No. 1SAC 1316 99 R0201

## 2.2.11 Description of ARCNET

### 2.2.11.1 Basic units with integrated ARCNET coupler

07 KT 98 R0160 (ARCNET)	Order No. GJR5 2531 00 R0160
07 KT 98 R0162 (ARCNET + PROFIBUS-DP)	Order No. GJR5 2531 00 R0162
07 KT 98 R0260 (ARCNET)	Order No. GJR5 2531 00 R0260
07 KT 98 R0262 (ARCNET + PROFIBUS-DP)	Order No. GJR5 2531 00 R0262
07 KT 98 R0268 (ARCNET + CANopen)	Order No. GJR5 2531 00 R0268
07 KT 98 R0276 (Ethernet + ARCNET)	Order No. GJR5 2531 00 R0276

### 2.2.11.2 Technical data

Connector X4	BNC
ARCNET interface	for coaxial cable
Recommended system cable	coaxial cable Type RG-62/U (char. impedance 93 Ω)
Cable length	305 m in case of ARCNET bus with 8 stations. For further details see SMC TECHNICAL NOTE TN7-1.
Signalling	operating condition "controller active", i.e. the PLC performs writing or reading operations
	operating condition "transmit active", i.e. the PLC is sending on the ARCNET
Electrical isolation	versus power supply voltage, inputs and outputs, versus the interfaces COM1/COM2

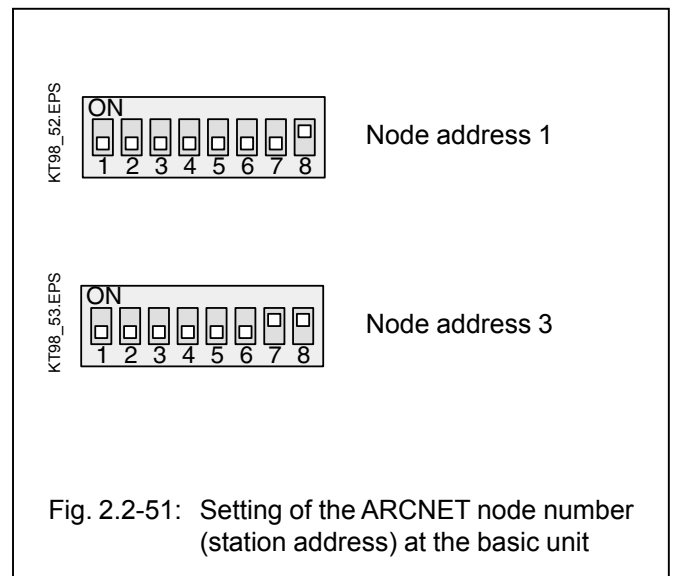
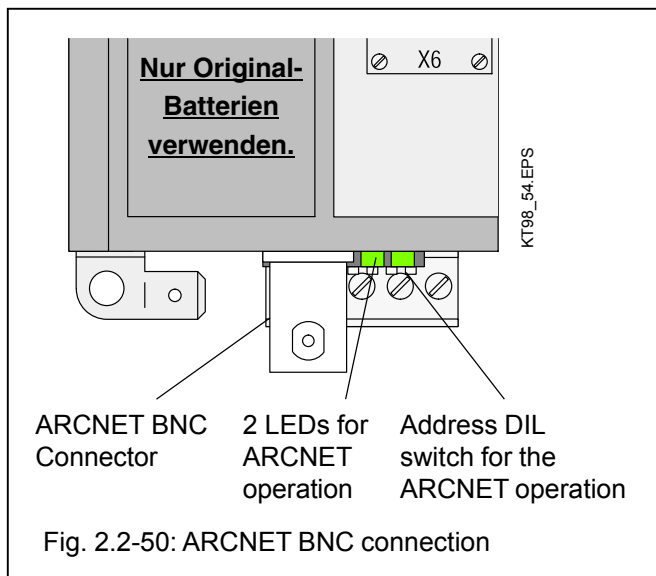

### 2.2.11.3 ARCNET short description

- The ARCNET coupler is integrated in the housing of the basic unit. The DIL switch for setting the ARCNET address is accessible from the outside of the housing. The ARCNET coupler is powered by the internal 24 V DC supply voltage.
- **Note:** The ARCNET interface is located on the upper side of the basic unit if there is also an Ethernet interface integrated.
- For ARCNET coupling, several function blocks are available.
- The ARCNET coupler interface is designed as a bus with BNC connector for coaxial cable. The ARCNET bus is earthed inside the module via a capacitor. As an EMC measure and for protection against dangerous contact voltages, the bus has to be earthed directly at a central place.
- Using the simplest configuration, called Linear ARCNET, a coaxial cable (RG-62, 93 Ω) is laid from station to station and connected with T plugs at all stations. At both ends of the cable, terminating resistors with 93 Ω each have to be installed.

#### 2.2.11.4 The ARCNET system (Attached Resource Computer Network)

- ARCNET is a system for data transmission in local networks.
- The ARCNET protocol is based on the Token Passing principle.
- By passing an identifier (token) from station to station it is guaranteed, that only one station can start a data transmission (transmission without collisions).
- The order of sequence, in which the stations are accessed, is automatically adapted by the existing conditions in the network, i.e. that the network is reconfigured automatically each time a station is added to the network or switched off.

##### 2.2.11.4.1 The networking configurations

###### Linear ARCNET

- In the Linear ARCNET configuration, the stations are connected to one another directly, i.e. without using any distribution units.
- Each station is connected to the network by using a T connector.
- Both cable ends must be terminated by termination resistors.
- A maximum of 8 stations can be connected to one Linear ARCNET.
- The maximum cable length of the network is 300 m.
- An additional segment can be connected at the end of the wired segment via an Active Hub (active distribution unit), see next page.

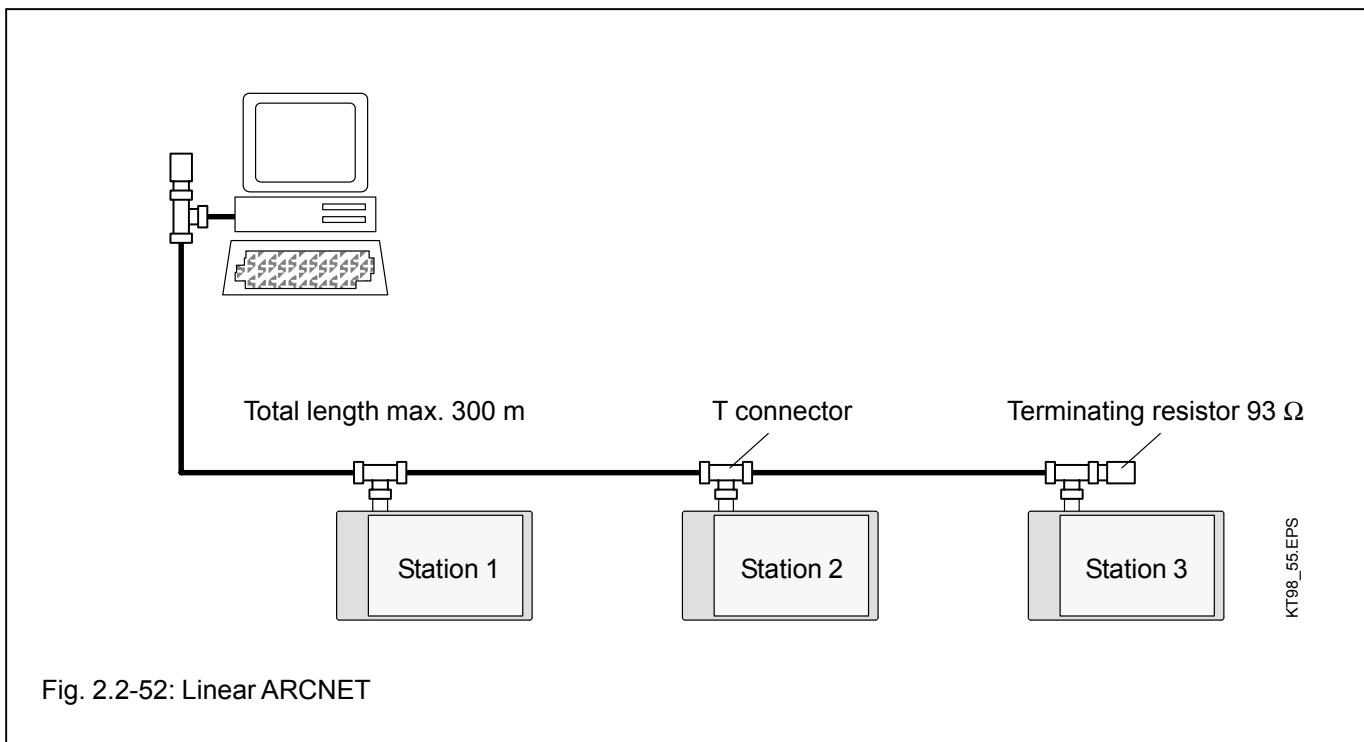

Fig. 2.2-52: Linear ARCNET

**Linear ARCNET, expanded by active distribution units (Active Hubs)**

- Active Hubs amplify the arriving signals. So they stabilize the network configuration and allow especially for high distances. The Active Hub decouples the station connectors from one another.

Therefore, the entire network does not fail when one of the connections fails.

- The maximum length of the network is 6 km.
- A maximum of 255 stations can be used.

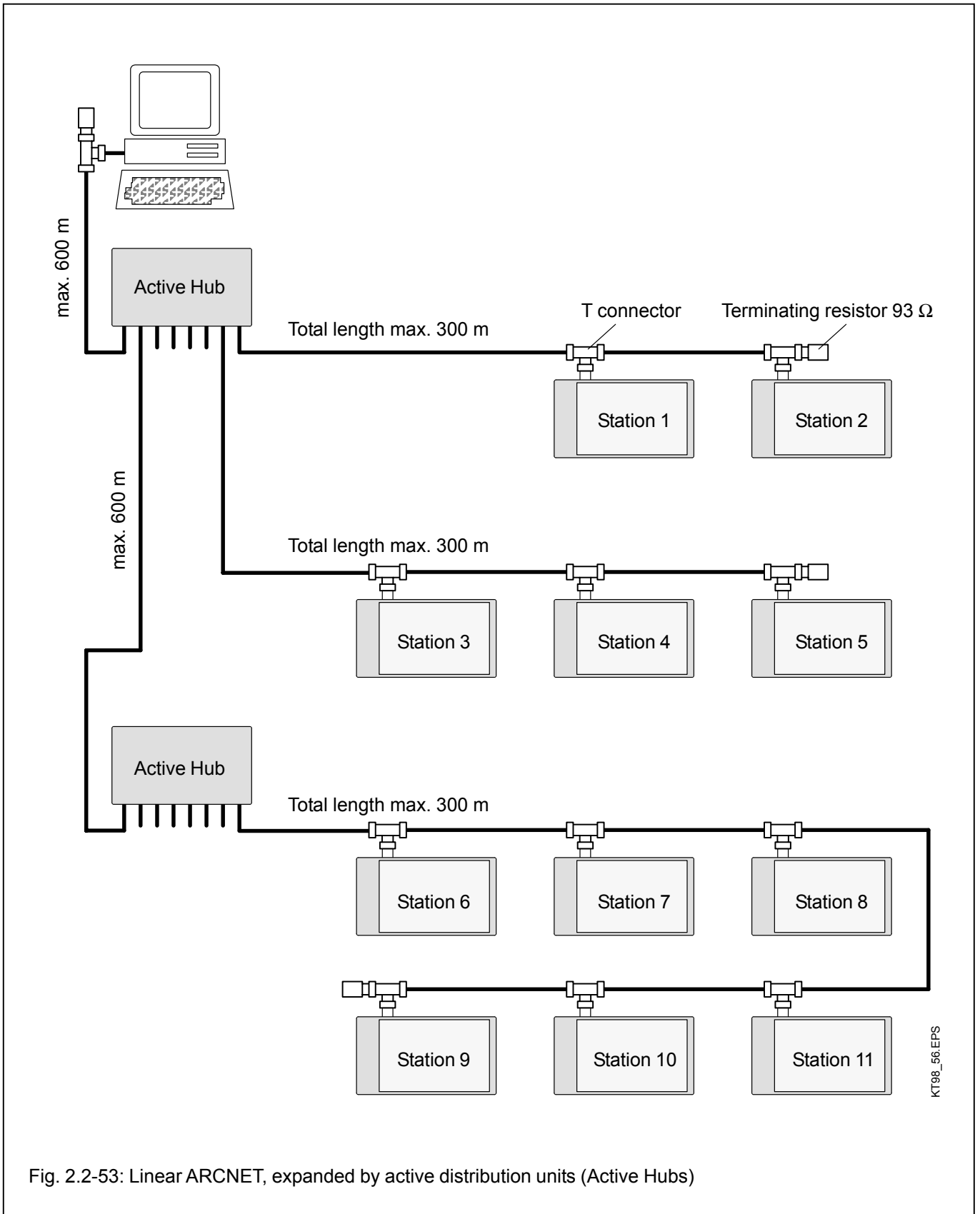

Fig. 2.2-53: Linear ARCNET, expanded by active distribution units (Active Hubs)

KT98\_56.EPS

#### 2.2.11.4.2 The features of the ARCNET system

- Data transmission rate 2.5 MBit/s
- Coaxial cable of type RG62/U, 93  $\Omega$
- Coaxial plugs, suitable for the coaxial cable
- Maximum number of stations: 255

#### Maximum distances

- The maximum distance between two stations amounts to 6 km.
- The maximum distance between an Active Hub and an ARCNET station or between two Active Hubs amounts to 600 m.
- The maximum distance between a Passive Hub and an ARCNET station or between an Active Hub and a Passive Hub is 30 m. A Passive Hub works like a resistor network which carries out the cable termination at the stations.
- The maximum distance within a Linear ARCNET configuration is 300 m. A maximum of 8 stations can be connected.

## 2.2.12 Description of the PROFIBUS-DP coupler

### 2.2.12.1 Basic units with integrated PROFIBUS-DP coupler

07 KT 98 R120 (PROFIBUS-DP)	Order No. GJR5 2531 00 R0120
07 KT 98 R162 (ARCNET + PROFIBUS-DP)	Order No. GJR5 2531 00 R0162
07 KT 98 R220 (PROFIBUS-DP)	Order No. GJR5 2531 00 R0220
07 KT 98 R262 (ARCNET + PROFIBUS-DP)	Order No. GJR5 2531 00 R0262
07 KT 98 R272 (Ethernet + PROFIBUS-DP)	Order No. GJR5 2531 00 R0272

### 2.2.12.2 Technical data of the integrated coupler

Coupler type	PROFIBUS coupler in PC/104 format
Processor	8-Bit processor with interrupt and DMA controller
Memory available	8 kByte DP RAM, 512 kByte Flash EPROM, 368 kByte RAM
Internal supply with	+5 V, 600 mA
Dimensions	96 x 91 x 13 mm

### 2.2.12.3 Technical data of the interface

Interface connector	9-pole SUB-D, female
Transmission standard	EIA RS-485
Transmission protocol	PROFIBUS-DP
Recommended system cable	shielded and twisted 2-core wire
Characteristic impedance	135...165 $\Omega$
Cable capacitance	< 30 pF/m
Diameter of the wire cores (copper)	> 0.64 mm
Cross section of the cable cores	> 0.32 mm <sup>2</sup>
Wire resistance per core	< 55 $\Omega$ /km
Loop resistance (resistance of 2 cores)	< 110 $\Omega$ /km
Transmission speed (baud rate)	9.6 kBit/s bis 12000 kBit/s
Maximum cable length	1200 m with baud rate 9.6 / 19.2 / 93.75 kBit/s 1000 m with baud rate 187.5 kBit/s 400 m with baud rate 500 kBit/s 200 m with baud rate 1500 kBit/s 100 m with baud rate 3000 / 6000 / 12000 kBit/s
Spur lines	are only permitted up to max. 1500 kBit/s, they should be prevented with 500 kBit/s or more for security purposes
Electrical isolation of the interface	test voltage max. 850 V
Display of statuses	with 4 LEDs (see Fig. 2.2-56)
Number of participants (masters/slaves) per bus segment	max. 32
Number of participants via repeater	max. 126

## 2.2.12.4 PROFIBUS-DP coupler

### Definitions, terms, abbreviations

PROFIBUS-DP	<b>PROCESS FIELDBUS - DECENTRAL PERIPHERY</b>
DP master (class 1)	normal bus master
DP master (class 2)	commissioning device
DP slave (DPS)	I/O module
DPV1	guideline for extended functions for PROFIBUS-DP
PNO	<b>PROFIBUS Nutzer-Organis-</b> sation (user organization)

### Standardization

EN 50170, DIN 19245 Part 1, DIN 19245 Part 3, DPV1

### Basics

PROFIBUS-DP is intended for fast data exchange in the field area. Here, central control units (e.g. PLC/PC) communicate with decentralized field devices like I/O, drives and valves via a fast serial connection. The data exchange with the decentralized modules is mainly performed cyclically. The communication functions, required for data exchange, are defined by the PROFIBUS-DP basic functions in accordance to EN 50170. For parametrization, diagnosis and alarm handling during the running cyclic data exchange, also non-cyclic communication functions are necessary for intelligent field devices.

### Location

The PROFIBUS-DP coupler is integrated in the housing of the basic unit. The bus interface is located on the top side to the left of the basic unit. There are also 4 LEDs for displaying statuses.

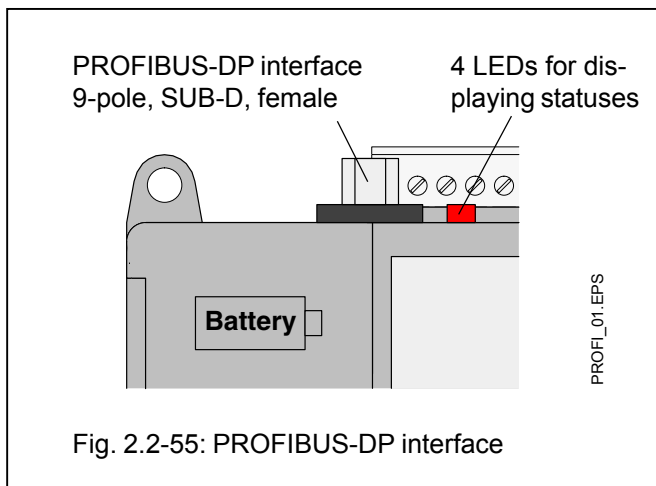

Fig. 2.2-55: PROFIBUS-DP interface

### Pin assignment, meaning of the LEDs

The following figure shows the pin assignment of the PROFIBUS-DP interface as well as the names of the 4 LEDs. The drawing is shown looking from the front side (as mounted in the switch-gear cabinet).

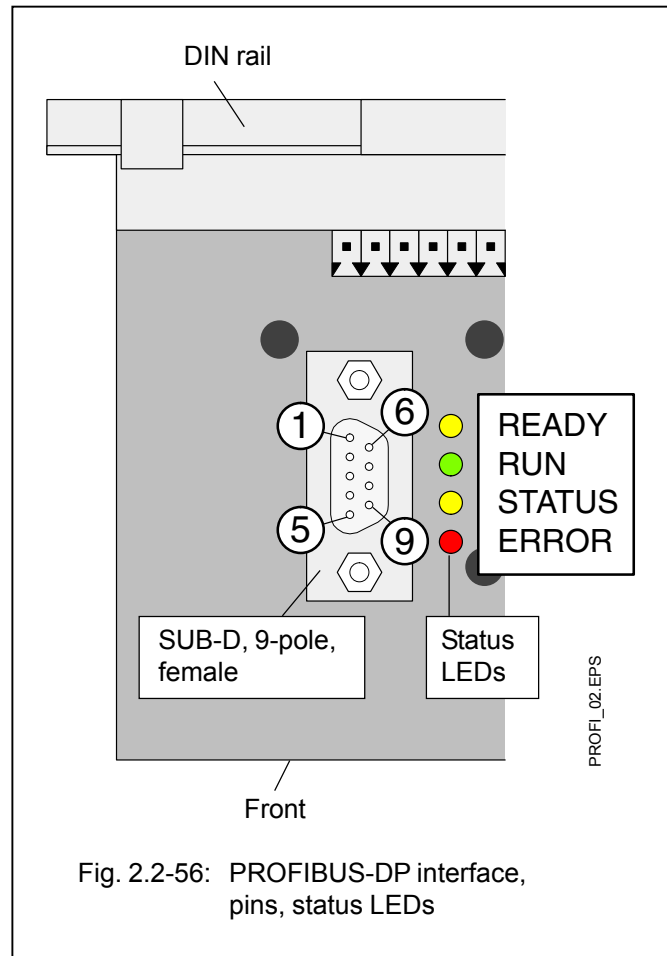

Fig. 2.2-56: PROFIBUS-DP interface, pins, status LEDs

### Pin assignment (SUB-D, 9-pole, female)

Pin No.	Signal	Meaning
1	Shield	shielding, protection earth
2	unused	
3	RxD/TxD-P	receive/transmit line, positive
4	CNTR-P	control signal for repeater, positive
5	DGND	reference potential for data exchange and +5 V
6	VP	+5 V (power supply for the bus terminating resistors)
7	unused	
8	RxD/TxD-N	receive/transmit line, negative
9	CNTR-N	control signal for repeater, negative



## Bus termination

The line ends (of the bus segments) must be equipped with bus termination resistors (show the drawing to the right). Normally, the resistors are integrated in the interface connectors.

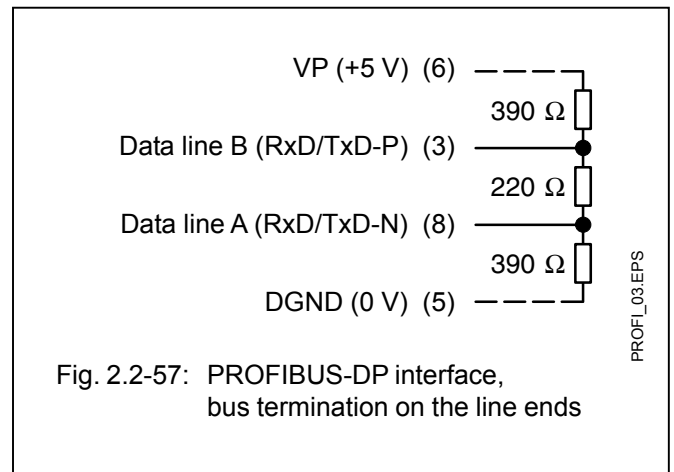

Fig. 2.2-57: PROFIBUS-DP interface, bus termination on the line ends

## Status LEDs

LED	Color	Condition	Meaning
READY	yellow	on flashes cyclic flashes non-cyclic off	coupler ready bootstrap loader active hardware or system error defective hardware
RUN	green	on flashes cyclic flashes non-cyclic off	communication is running communication is stalled missing or erroneous configuration no communication
STATUS	yellow	on  off	DP slave: data exchange with DP master DP master: transmits data or token DP slave: no data exchange DP master: no token
ERROR	red	on off	PROFIBUS error no error

The condition of the PROFIBUS coupler is indicated with the 4 status LEDs.

After power ON the coupler initializes a self-test. If this test was successful, the yellow READY LED goes ON. Otherwise the LED starts flashing and aborts the further initialization. If the LED remains OFF, the coupler is defective.

In the course of initialization, the RUN LED is OFF for the first time. The LED is only activated after configuration data has been sent to the coupler and the operating mode of the coupler was set. If the operating system of the coupler detects a parameterization or a configuration error, the green RUN LED flashes non-cyclically. If this LED flashes cyclically, the coupler is ready for communication, but the communication is not active yet. In case of an active communication, the RUN LED lights continuously.

The red ERROR LED indicates errors on the PROFIBUS interface.

In the operating mode DP slave, the yellow STATUS LED indicates the active I/O data exchange with the DP master. In the operating mode DP master, the STATUS LED indicates the ownership of the token and therefore the I/O data exchange with the involved DP slaves.

During the initialization procedure and also if the coupler is configured (anew) - in particular if the operating mode was changed - it can occur that all or some LEDs light up for a short period of time, before reaching a defined condition.

### Important address

PROFIBUS Nutzerorganisation e. V. (PNO)  
Haid-und-Neu-Straße 7  
D-76131 Karlsruhe

Tel.: (+49) 721 9658 590

Fax: (+49) 721 9658 589

Internet: <http://www.profibus.com>

## 2.2.13 Description of the CANopen Master coupler

### 2.2.13.1 Basic units with an integrated CANopen Master coupler

07 KT 98 R268 (ARCNET + CANopen)  
07 KT 98 R278 (Ethernet + CANopen)  
07 KT 98 R280 (CANopen)

Order No. GJR5 2531 00 R0268  
Order No. GJR5 2531 00 R0278  
Order No. GJR5 2531 00 R0280

### 2.2.13.2 Technical data of the integrated coupler

Coupler type	CANopen Master coupler in PC/104 format
Processor	16-bit processor with interrupt and DMA controller
Memory available	8 kbyte DP-RAM, 512 kbyte Flash EPROM, 128 kbyte RAM
Internal supply with	+5 V, 650 mA
Dimensions	96 x 90 x 23 mm
CE sign	55011 Class b for emission, EN 50082-2 for noise immunity

### 2.2.13.3 Technical data of the interface

Interface connector	5-pole COMBICON, female
Transmission standard	ISO 11898, isolated
Transmission protocol	CANopen (CAN), max. 1 Mbaud
Transmission speed (baud rate)	20 kbit/s, 125 kbit/s, 250 kbit/s, 500 kbit/s und 1 Mbit/s
Display of statuses	by 4 LEDs (see Fig. 2.2-59)
Number of participants	max. 127 slaves

### 2.2.13.4 Short description

CANopen is a standardized 7-layer protocol for decentralized industrial automation systems, based on the Controller Area Network (CAN) and the CAN Application Layer (CAL).

CANopen bases on a communication profile in which the basic communication mechanisms and their descriptions are defined, e.g. mechanisms for interchange of process data in real time or transmitting of alarm messages.

The different CANopen device profiles make use of this common communication profile. The device profiles describe the specific functionality of a device class or its parameters. For the most important device classes used in the industrial automation technology, such as digital and analog input/output modules, sensors, drives, operator panels, loop controllers, programmable control systems and encoders, suitable device profiles exist. Others are in preparation.

A central element of the CANopen standard is the description of the device functionality in an object directory.

The object directory is subdivided into a general part and a device-specific part. The general part contains details on the device, such as device identification, name of manufacturer, communication parameters etc. The device-specific part describes the specific functionality of the concerned device. These features of a CANopen device are described in a standardized Electronic Data Sheet (EDS).

A CANopen network consists of a maximum of 128 devices, one NMT master and a maximum of 127 NMT slaves. In contrast to other typical master-slave systems such as PROFIBUS, the CANopen terms Master and Slave have a different meaning.

In operational mode, all devices are able to transmit messages via the bus. In addition, the master can change the operating mode of the slaves.

Normally a CANopen master is realized by a PLC or a PC. The bus address of a CANopen slave can be set from 1 to 127. By the device address, a number of identifiers are created, which are then used by the device.

### 2.2.13.5 Location

The CANopen coupler is integrated in the housing of the basic unit. The bus interface is located on the top side to the left of the basic unit. There are also the 4 LEDs for displaying statuses.

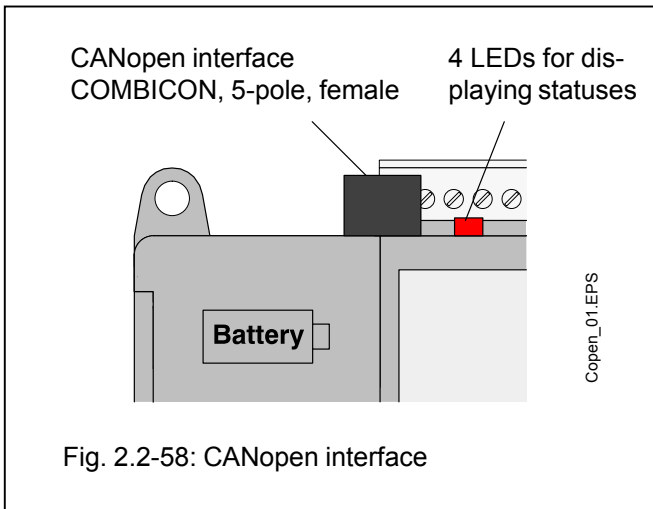

Fig. 2.2-58: CANopen interface

### 2.2.13.6 Pin assignment, meaning of the LEDs

The following figure shows the pin assignment of the CANopen interface as well as the names of the 4 LEDs. The drawing is shown looking from the front side (as mounted in the switch-gear cabinet).

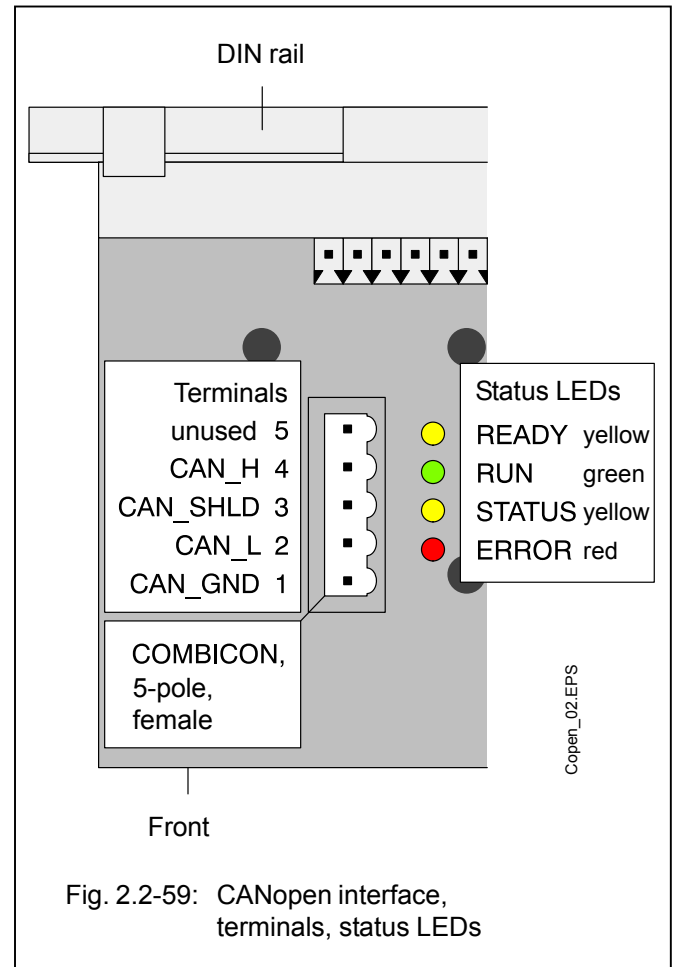

Fig. 2.2-59: CANopen interface, terminals, status LEDs

#### Terminal assignment (COMBICON, 5-pole, female)

Pin No.	Signal	Meaning
1	CAN_GND	CAN Ground
2	CAN_L	CAN_L bus line, Receive/Transmit low
3	CAN_SHLD	Shield of the bus cable
4	CAN_H	CAN_H bus line, Receive/Transmit high
5	unused	

## Status LEDs

LED	Color	Condition	Meaning
READY	yellow	on flashes cyclic flashes non-cyclic off	Coupler ready Bootstrap loader active Hardware or system error Defective hardware
RUN	green	on flashes cyclic flashes non-cyclic off	Communication is running Communication is stalled Missing or faulty configuration No communication
STATUS	yellow	on off	Coupler transmits data Coupler does not transmit data
ERROR	red	on off	CANopen error No error

### 2.2.13.7 Bus termination

The data line ends must be equipped with 120-Ohm bus terminating resistors. Normally, the resistors are integrated in the interface connectors.

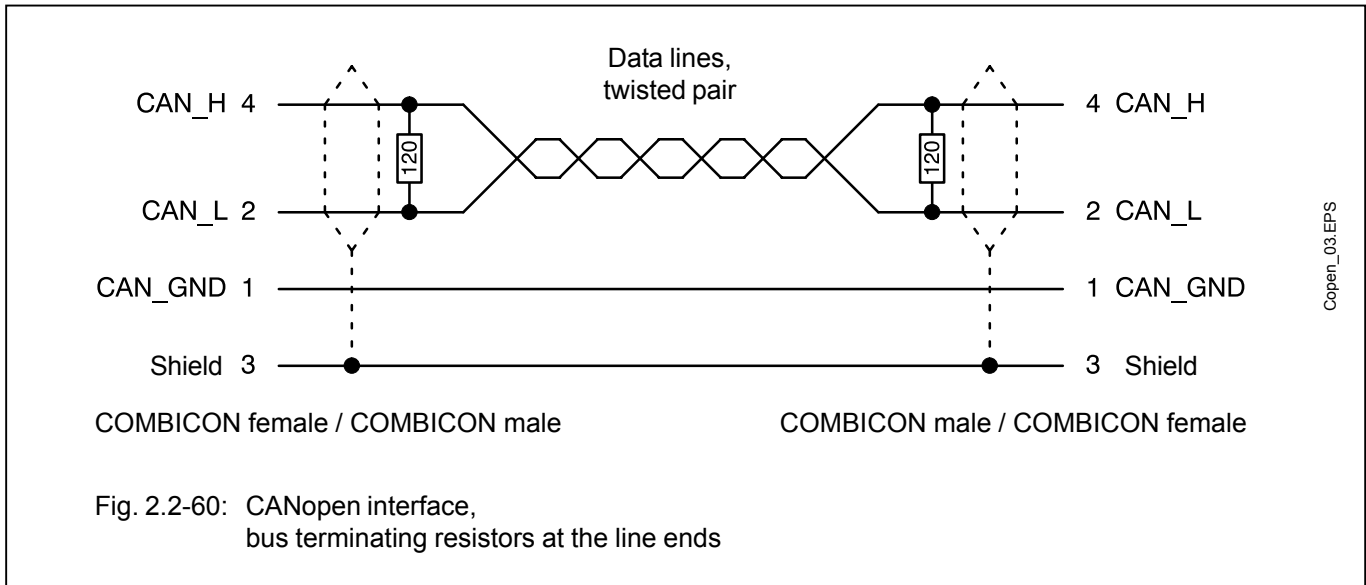

## 2.2.14 Description of the Ethernet coupler

### 2.2.14.1 Basic units with integrated Ethernet coupler

07 KT 98 R270 (Ethernet)	Order No. GJR5 2531 00 R0270
07 KT 98 R272 (Ethernet + PROFIBUS-DP)	Order No. GJR5 2531 00 R0272
07 KT 98 R276 (Ethernet + ARCNET)	Order No. GJR5 2531 00 R0276
07 KT 98 R277 (Ethernet + Ethernet)	Order No. GJR5 2531 00 R0277
07 KT 98 R278 (Ethernet + CANopen)	Order No. GJR5 2531 00 R0278

### 2.2.14.2 Technical data of the integrated coupler

Coupler type	Ethernet coupler in PC/104 format
Processor	EC1-160, system clock 48 MHz
Ethernet controller	EC1-160, internally
Interfaces	Ethernet Diagnosis
	10 / 100 BASE-TX / RJ45 MiniDIN, 8-pole, female
LED displays	RDY - System o.k. RUN - Configuration o.k. / Communication is running ERR - Communication error STA - Status of the Ethernet communication
Setting the station identifier	00 <sub>H</sub> to FF <sub>H</sub>
Internal supply with	+5 V, 300 mA
Dimensions	90 x 96 x 23 mm

### 2.2.14.3 Technical data of the software

Firmware	Protocol suite	UDP/IP TCP/IP Open MODBUS on TCP others in preparation
	EthernetIP	Slave only Cyclic and non-cyclic data transfer

### 2.2.14.4 Short description

The Ethernet coupler is an intelligent 100-Base-T-Ethernet communication interface based on the highly integrated microcontroller EC1. The coupler supports the complete TCP/IP protocol and the application layers, too.

The user interface is based on a dual-port memory.

The coupler meets the PC/104 standard. It is powered by the internal 5 V supply voltage.

The Ethernet communication is run via an RJ45 interface. In addition, the coupler has a diagnosis interface in Mini-DIN format.

The coupler is configured via the dual-port memory, the diagnosis interface or a TCP/IP connection by means of a system configurator. The configuration is saved non-volatile in a Flash EPROM.

### 2.2.14.5 Location

The following figure shows a basic unit with two Ethernet couplers, which are located on the bottom side to the left of the basic unit. Units which have only one coupler, use coupler No. 1.

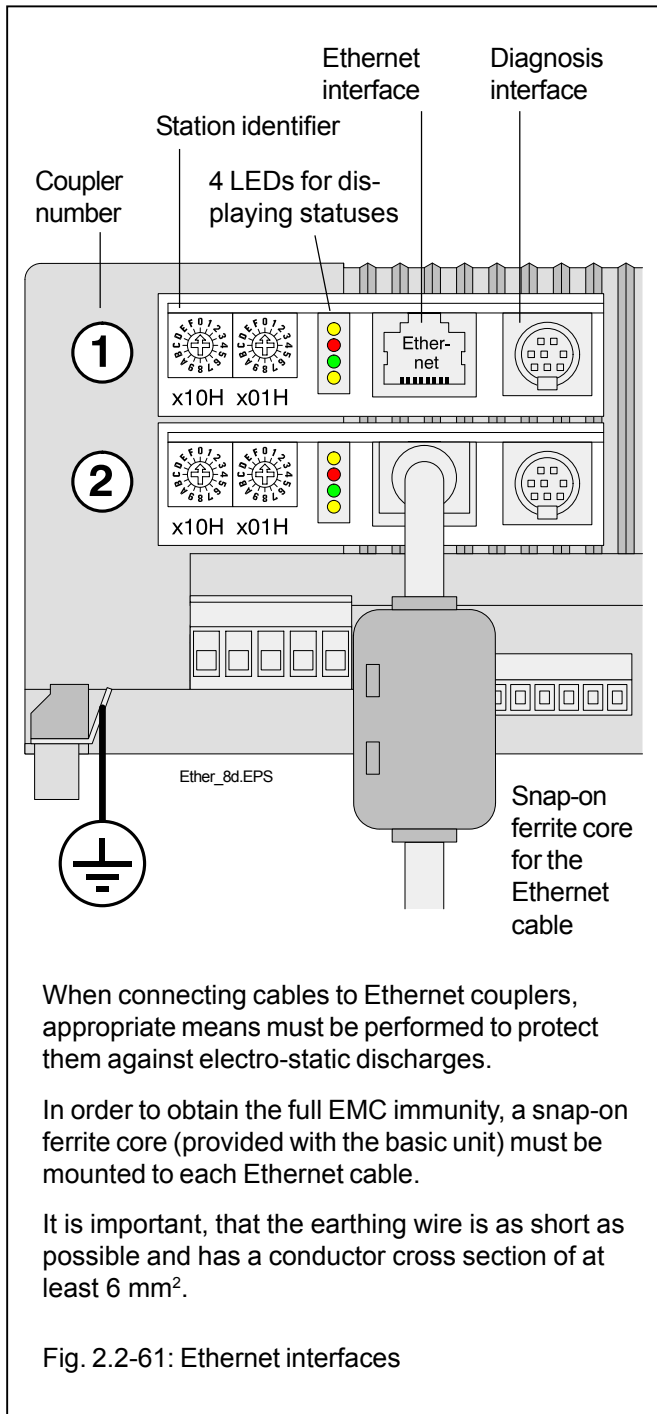

### 2.2.14.6 Station identifier

The following figure shows the setting of the station identifier.

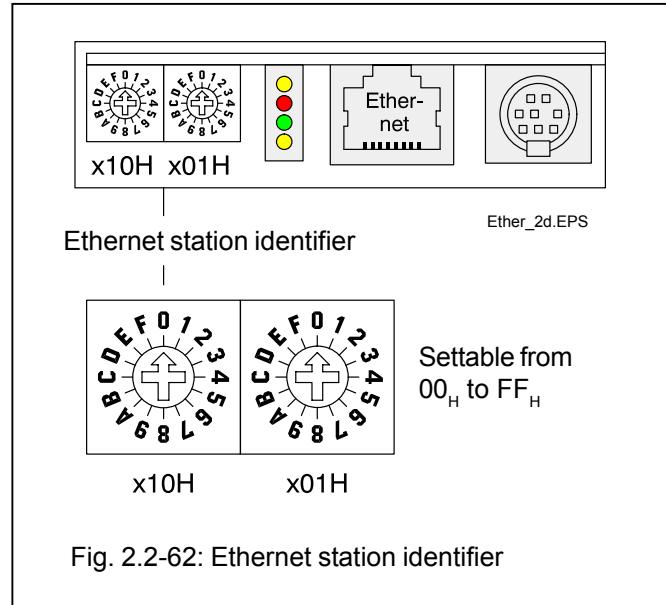

### 2.2.14.7 Ethernet interface

The following figure shows the Ethernet interface.

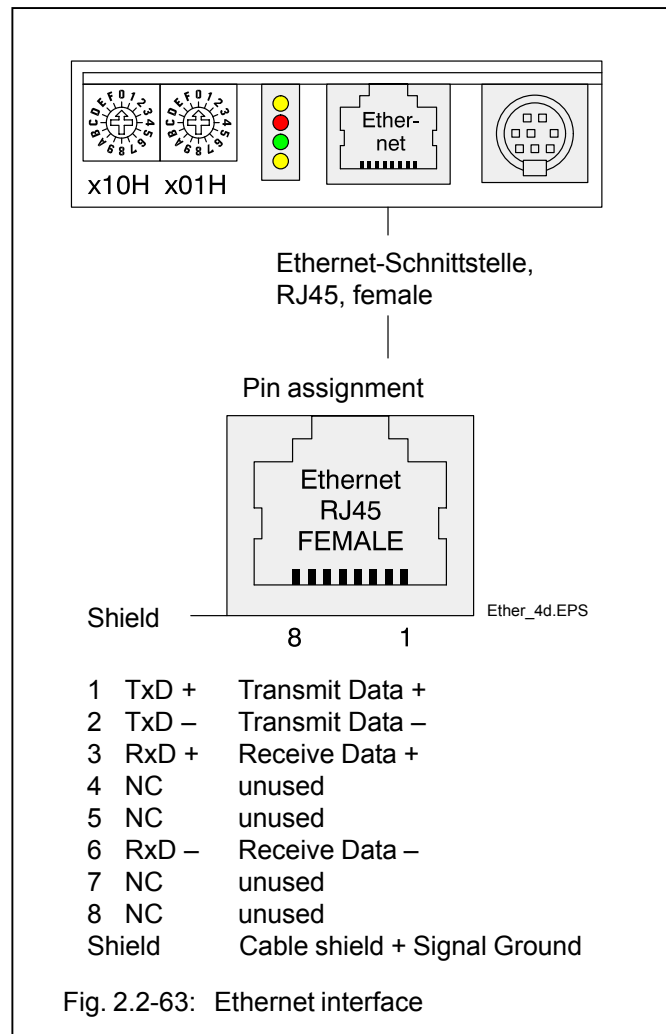

### 2.2.14.8 Diagnosis interface

The following figure shows the diagnosis interface.

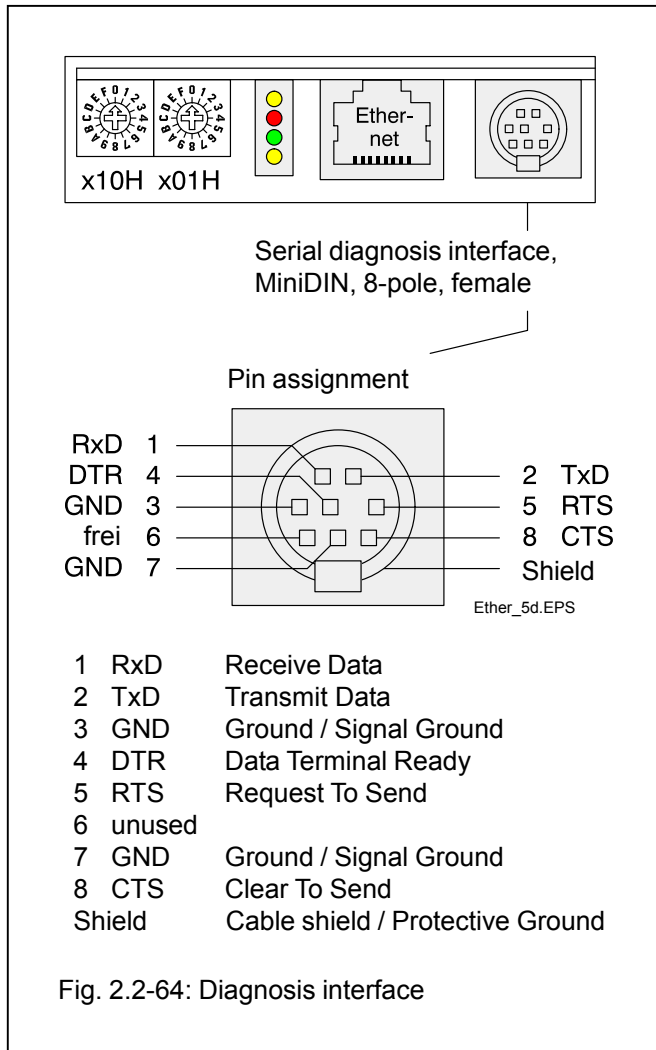

### 2.2.14.9 Meaning of the LEDs

The following figure shows the 4 status LEDs.

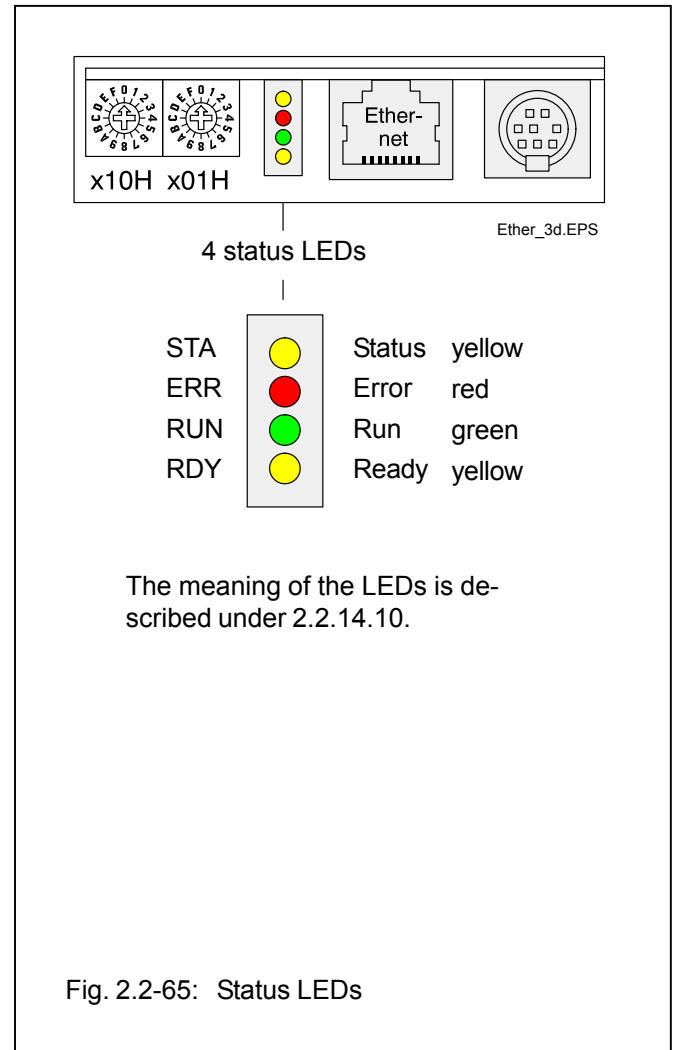

### 2.2.14.10 Status LEDs

LED	Color	Condition	Meaning
STATUS	yellow	flashes	Ethernet frame detected on the network
ERROR	red	on off	Error No error
RUN	green	eon flashes cyclic flashes non-cyclic off	Communication is running Ready for communication Parameterization error No communication
READY	yellow	on flashes cyclic flashes non-cyclic off	Coupler is ready Bootstrap loader is active Hardware or system error Defektive hardware









---

**ABB STOTZ-KONTAKT GmbH**

Eppelheimer Straße 82    Postfach 101680  
69123 Heidelberg        69006 Heidelberg  
Germany                    Germany

Telephone    +49 6221 701-0  
Telefax        +49 6221 701-240  
E-Mail         desst.help@de.abb.com  
Internet        <http://www.abb.de/stotz-kontakt>

# Advant Controller 31

Intelligent Decentralized  
Automation System

## Basic Unit

07 SL 97

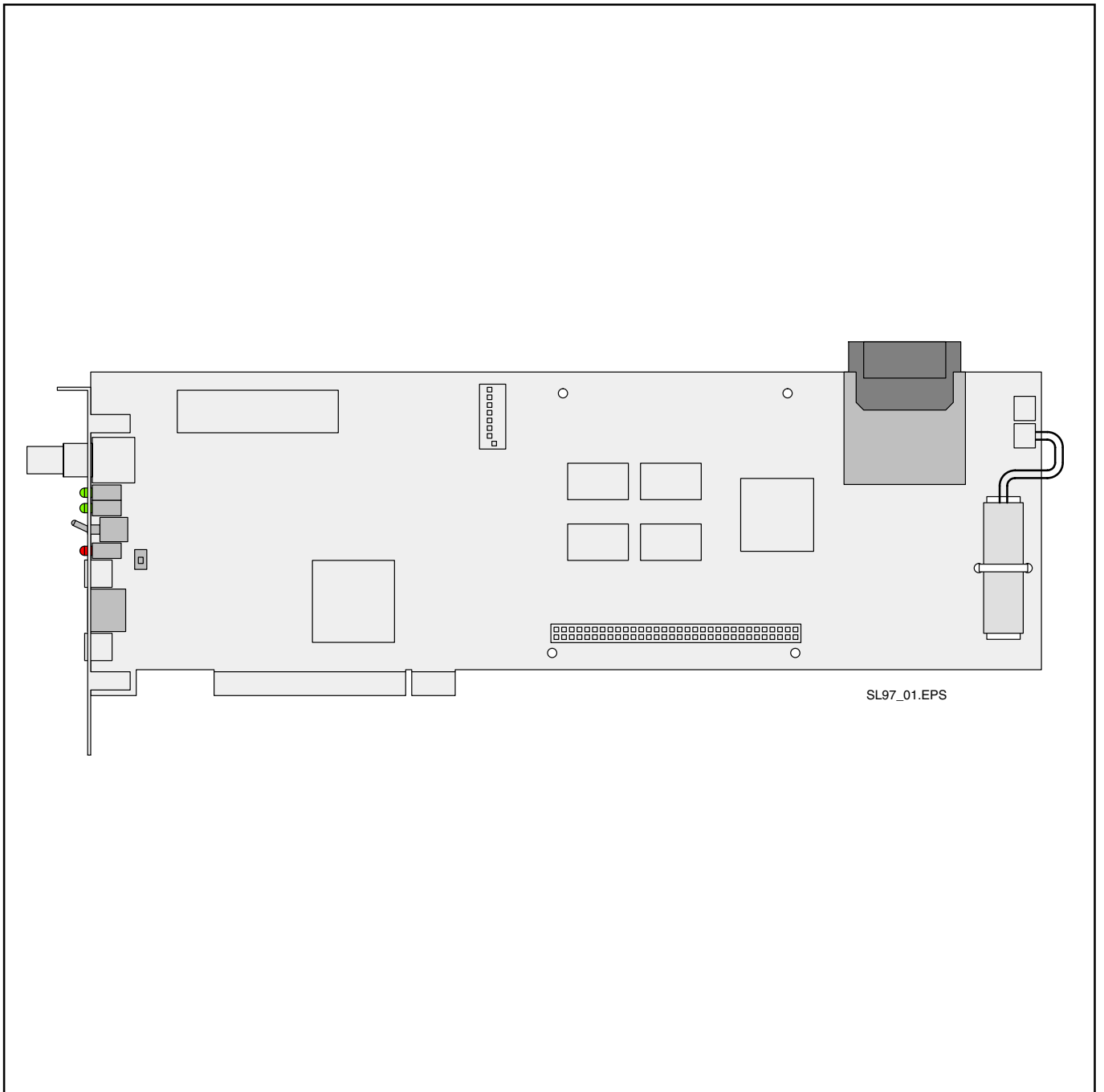

SL97\_01.EPS



## 2.3 Basic Unit 07 SL 97

Basic unit with max. 480 kB user program + 256 kB user data,  
CS31 system bus

The basic unit **07 SL 97** is a slot PLC and can be integrated into PCs with PCI interface. This plug-in card is designed as a standard PCI full-size card. The basic unit **07 SL 97 R0160** has a CS31 bus connection as well as an ARCNET coupling.

Optionally further couplings are possible for the following units:

PROFIBUS-DP   **07 SL 97 R0162**   and  
DeviceNet       **07 SL 97 R0165.**

A table listing the options is shown on the following page.

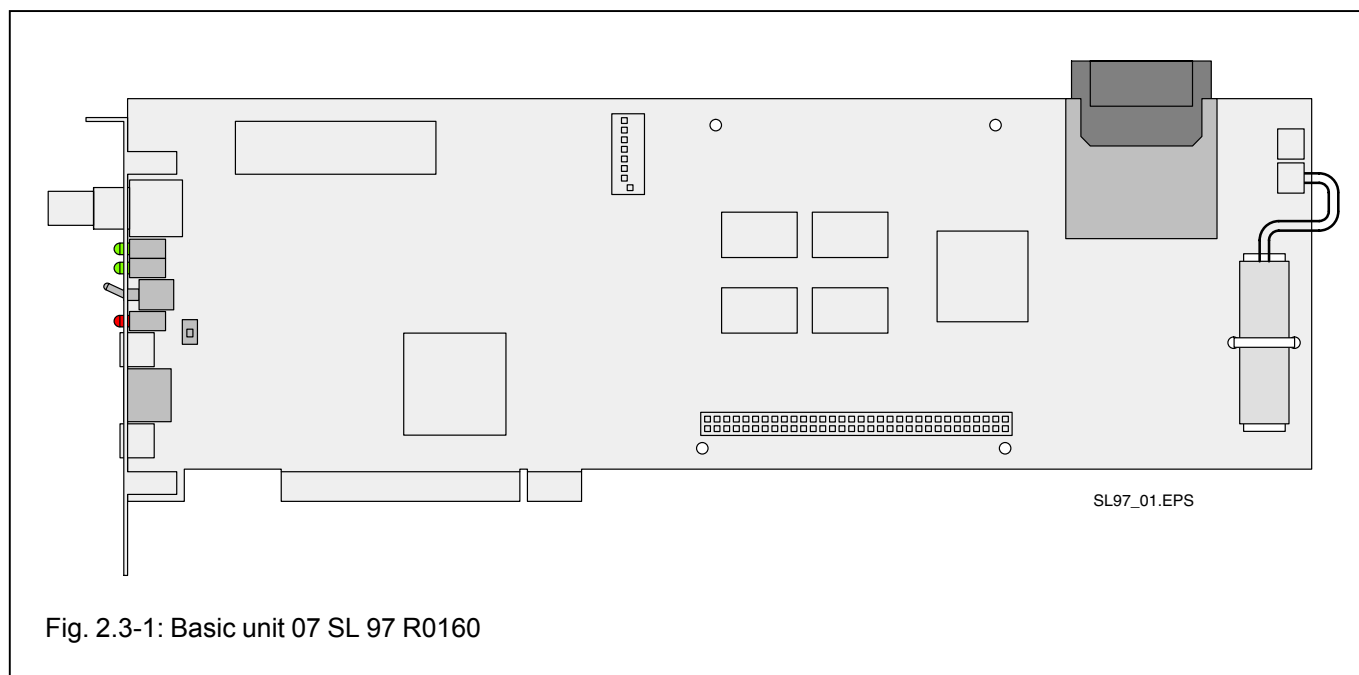

Fig. 2.3-1: Basic unit 07 SL 97 R0160

### Contents

<b>2.3.1</b>	<b>Brief description</b> .....	page 2.3-3	<b>2.3.5</b>	<b>SmartMedia Card</b> .....	page 2.3-16
2.3.1.1	Main features .....	3	<b>2.3.6</b>	<b>Technical data 07 SL 97</b> .....	17
2.3.1.2	Project planning / Commissioning .....	3	2.3.6.1	General data .....	17
<b>2.3.2</b>	<b>Connections and operating elements</b> .....	4	2.3.6.2	Power supply .....	17
<b>2.3.3</b>	<b>Electrical connection</b> .....	5	2.3.6.3	Lithium battery .....	18
2.3.3.1	Connection of the supply voltage .....	6	2.3.6.4	Connection of the serial interface COM1 .....	18
2.3.3.2	Connection for the CS31 system bus .....	6	2.3.6.5	Connection to the CS31 system bus .....	18
2.3.3.3	Battery and battery replacement .....	7	2.3.6.6	PCI interface .....	18
2.3.3.4	Serial interface COM1 .....	8	2.3.6.7	Connection to ARCNET .....	18
<b>2.3.4</b>	<b>Networking / Couplers</b> .....	9	2.3.6.8	LED displays .....	19
2.3.4.1	Basic units with ARCNET coupler .....	9	2.3.6.9	Mechanical data .....	19
2.3.4.2	Basic unit with PROFIBUS-DP coupler .....	10	2.3.6.10	Mounting hints .....	20
2.3.4.4	Basic unit with DeviceNet coupler .....	13	2.3.6.11	Ordering data .....	20

## Functionality of the basic units 07 SL 97

User program	480 kB (Flash EPROM)
User data	256 kB
Serial interfaces	COM1 as MODBUS interface and for programming and test functions
Internal interface for connection to coupler	Optionally for PROFIBUS-DP coupling card or DeviceNet coupling card
System bus interface	CS31
Integrated couplers	ARCNET
PCI interface	Acc. to PCI interface specification V2.1 (PCI = Peripheral Component Interconnect) 32 bit bus / 33 MHz Self-configuring PCI card, designed in 5 V technology PCI interface realized using PLX chip 8 k memory range on PCI bus Interrupt processing as PCI target Interrupt setting depending on the PC
Real-time clock	integrated
SmartMedia Card	Storage medium for operating system, user program and user data
LED displays	for signal states, operating conditions and error messages
Power supply	24 V DC
Data buffering	with Lithium battery 07 LE 90
Programming software	907 AC 1131

Available basic units 07 SL 97			
Basic unit	07 SL 97 R0160	07 SL 97 R0162	07 SL 97 R0165
Binary inputs	-	-	-
Binary outputs	-	-	-
Binary inputs/outputs	-	-	-
Analog inputs	-	-	-
Analog outputs	-	-	-
CS31 bus connection	yes	yes	yes
ARCNET interface	yes	yes	yes
PROFIBUS-DP interface	no	yes	no
DeviceNet interface	no	no	yes
Order number	GJR5 2534 00 R0160	GJR5 2534 00 R0162	GJR5 2534 00 R0165

## 2.3.1 Brief description

The basic unit 07 SL 97 can work as:

- Bus master basic unit on the CS31 system bus
- Bus master basic unit on the CS31 system bus with ARCNET networking
- Bus master basic unit on the CS31 system bus with ARCNET networking and coupling to PROFIBUS-DP or DeviceNet
- Basic unit with ARCNET networking
- Basic unit with ARCNET networking and coupling to PROFIBUS-DP or DeviceNet
- Basic unit with coupling to PROFIBUS-DP or DeviceNet
- Slave basic unit on the CS31 system bus

The supply voltage for the unit is 24 V DC.

### 2.3.1.1 Main features

- 1 PCI interface V2.1
- 1 ARCNET interface
- 1 CS31 system bus interface for system expansion
- 1 interface for connecting communication modules
- 1 serial interface COM1
  - as MODBUS interface and
  - for programming and test functions
- Real-time clock
- LEDs for displaying operating conditions and error messages
- Detachable screw-type terminal blocks
- Fastening inside the PC by inserting the slot PLC into the PCI direct plug connector
- A lithium battery 07 LE 90 can be inserted into the battery compartment in order to
  - store and backup data additionally contained in the RAM, e.g. states of the flags
  - backup the time and date (real-time clock)
- RUN/STOP switch for starting and aborting the program execution
- Extensive diagnosis functions
  - self-diagnosis of the basic unit
  - diagnosis of the CS31 system bus and the connected modules

- Integrated Flash EPROM for storing program and data
- Exchangeable SmartMedia Card 07 MC 90 for user data and for updating the operating system or the PLC program
- Separate 24 V DC power supply which is independent from the PC
- Diagnosis of the 07 SL 97 via the PC and via ARCNET diagnosis of further connected decentralized processors, such as 07 KT 97/98 (Routing)
- Remote diagnosis using 907 AC 1131 in connection with standard software (e.g. PC Anywhere)
- OPC interface

### 2.3.1.2 Project planning / Commissioning

The following has to be observed for project planning and commissioning:

- Programming is performed using the AC31 programming software which can be run on standard IBM compatible PCs with Windows NT and Windows 98 SE (refer to the documentation of the programming system 907 AC 1131).
- Online program modification Quick modification of the user program is possible without interruption of operation (refer to programming system 907 AC 1131).
- Buffering of data areas Buffering of data, i.e. saving of data during power OFF/ON, is only possible when a battery is available. Furthermore data can be stored on the SmartMedia Card in order to become voltage breakdown-safe.

## 2.3.2 Connections and operating elements

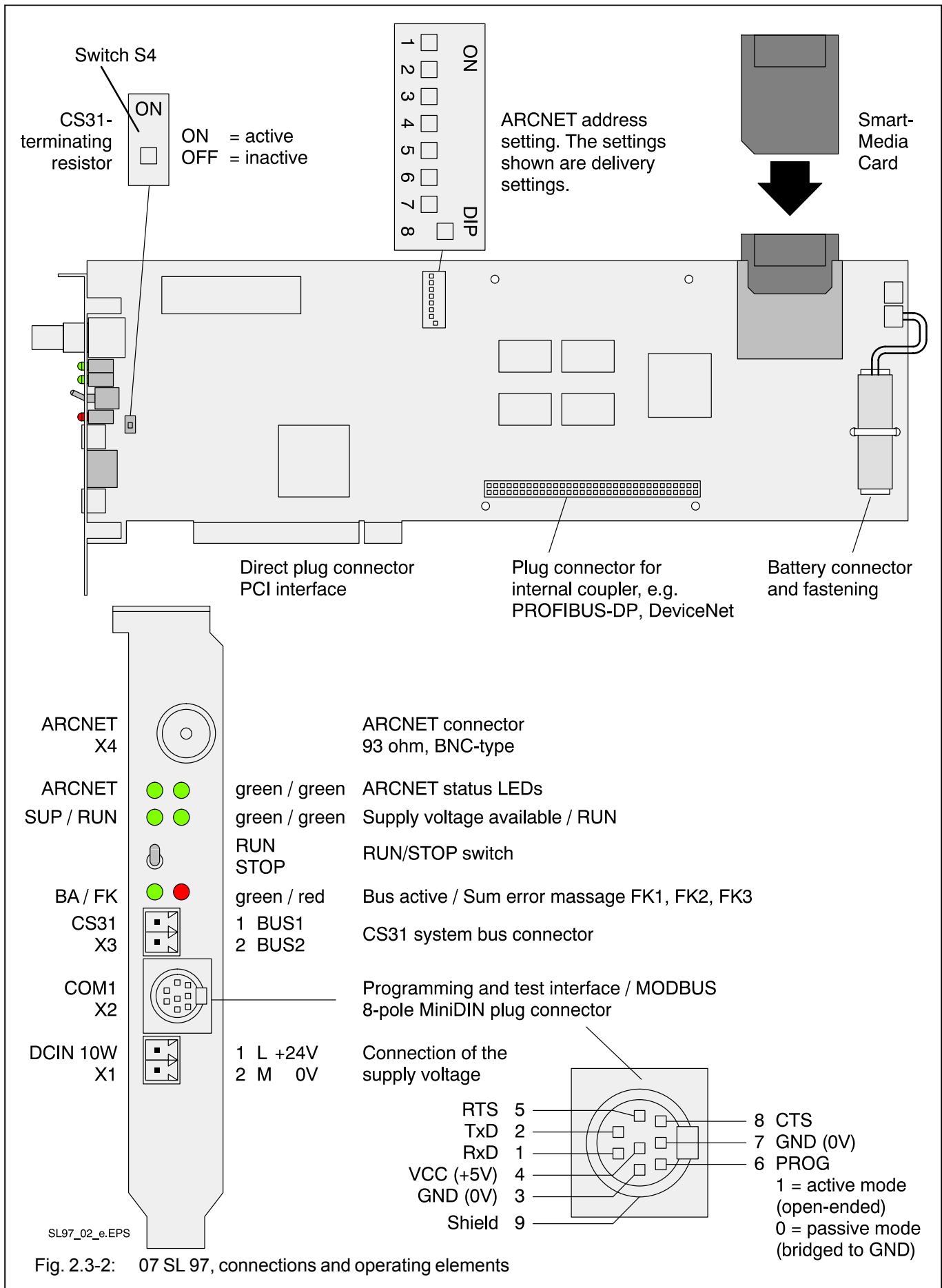
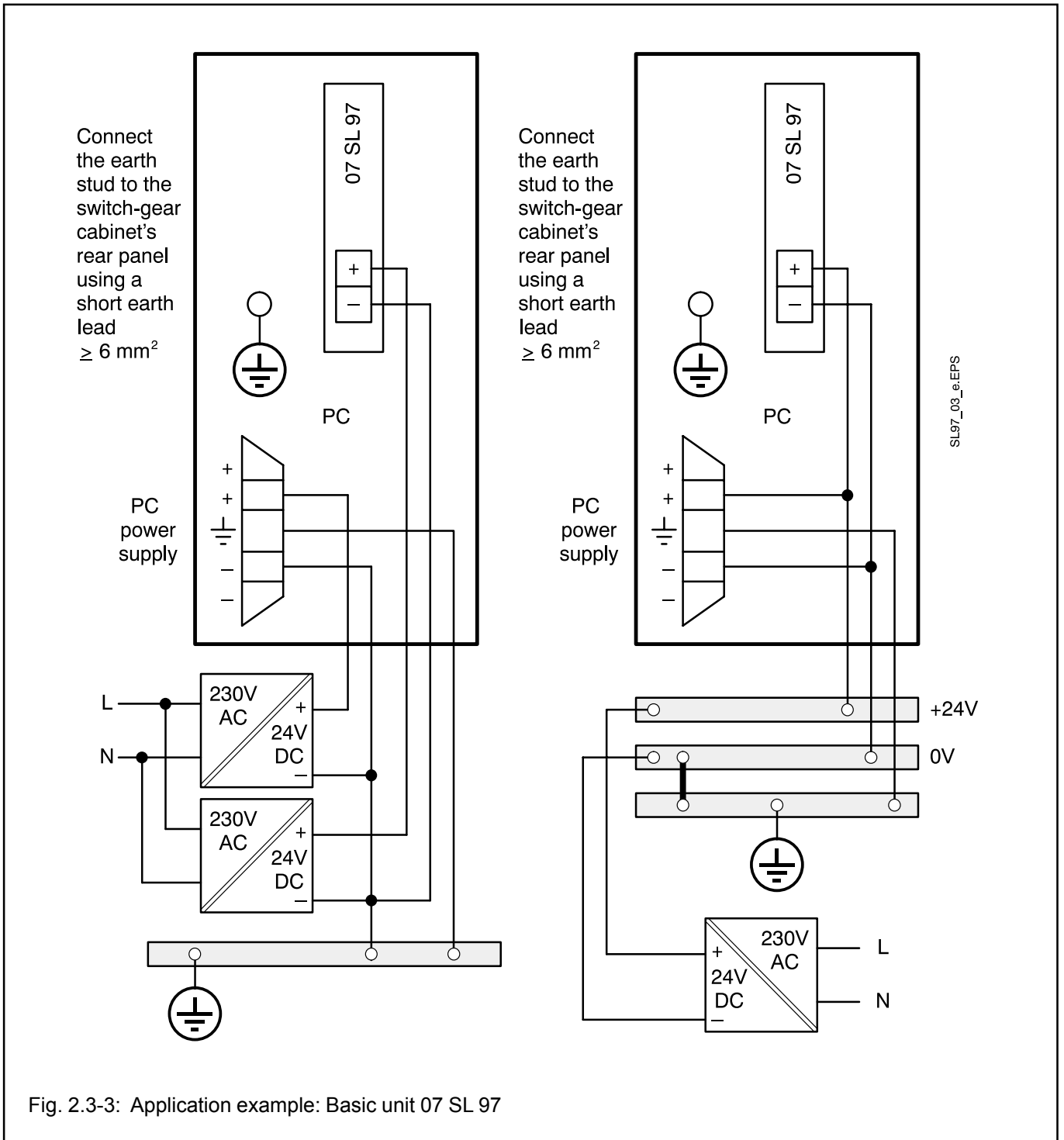

Fig. 2.3-2: 07 SL 97, connections and operating elements



### 2.3.3 Electrical connection / earthing concept

- Connect the earth connection (e.g. earth stud) of the PC housing to functional earth (switch-gear cabinet earth) using an 6 mm<sup>2</sup> earth lead which is as short as possible.
- Connect the CS31 bus according to chapter 1.2 „CS 31 system bus“ in part 1 „Hardware“ of the 907 AC 1131 system description.



### 2.3.3.1 Connection of the supply voltage

The 24 V DC supply voltage is connected via a 2-pole detachable screw-type terminal block.

**Caution: Plug and unplug the terminal block only when power is off!**

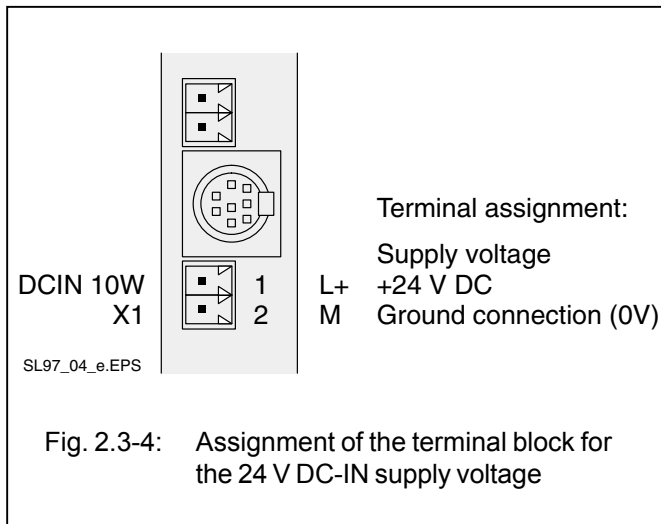

Using a power supply for the 07 SL 97 which is separate from the PC provides high availability of the slot PLC. The PLC program of the slot PLC works independent from the PC. Therefore the communication with the CS31 bus modules and the ARCNET, PROFIBUS or DeviceNet subscribers is maintained. The communication between the slot PLC and the PC can be started after the power supply of the PC is switched on.

### 2.3.3.2 Connection for CS31 system bus

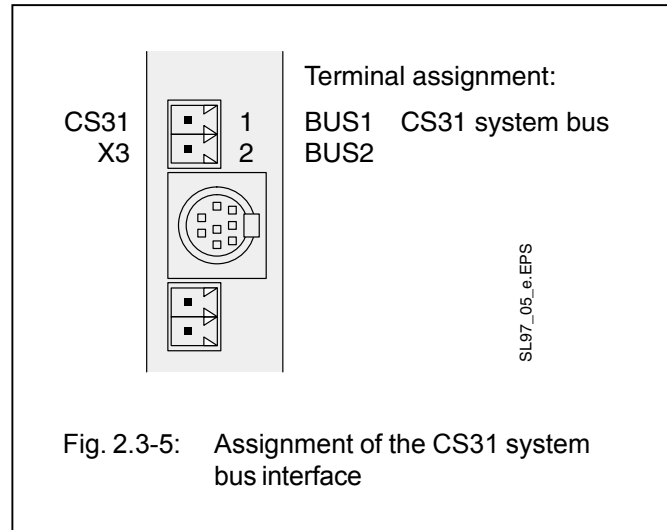

The connection to the CS 31 system bus is made via a 2-pole detachable terminal block. Please observe:

- All AC31 devices, no matter whether they are master or slave devices, are connected by a twisted-pair bus line as follows:
  - One core of the bus line is looped through via the BUS1 terminals of all devices to be connected to the CS31 system bus.
  - The other core of the bus line is looped through via the BUS2 terminals of all devices to be connected to the CS31 system bus.
- If the 07 SL 97 device is located at the beginning or at the end of the bus line, the bus terminating resistor (120 Ω) on the board has to be switched on using switch S4.

The mounting position of switch S4 is shown in chapter 2.3.2 „Connections and operating elements“ on page 2.3-4.

Switch in „On“ position = Bus terminating resistor **active**

Switch in „Off“ position = Bus terminating resistor **inactive**

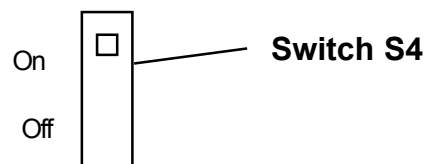

- The shield of the twisted-pair bus line is connected with a clamp to the metal housing of the PC.
- Handling of the CS31 system bus is described in detail in volume 2 „System data“.

### 2.3.3.3 Battery and battery replacement

- The lithium battery 07 LE 90 can be used for data backup purposes as follows:
  - Storage and backup of data additionally contained in the RAM memory, e.g. states of the flags
  - Backup of time and date

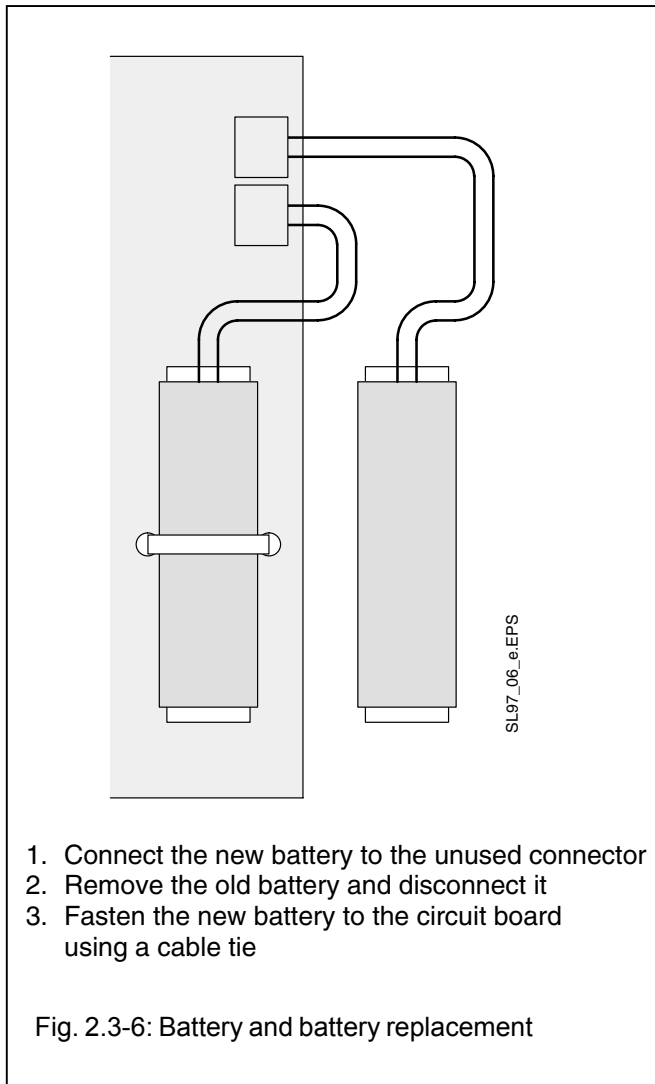

The battery lifetime is typically 5 years. The battery lifetime is the time during which the device remains operable in order to backup data while the supply voltage of the basic unit is switched off. As long as the supply voltage is available there is no more load on the battery other than its self-discharge.

Please observe the following handling notes:

- Use only lithium batteries approved by ABB.
- Replace the battery by a new one at the end of its life.
- **Observe the instructions of the PC manufacturer before opening the PC housing!**
- **Never short-circuit the battery!** There is danger of overheating and explosion. Avoid accidental short-circuits. Therefore do not store batteries in metallic containers or boxes and do not bring them into contact with metallic surfaces.
- **Never try to charge a battery!** Danger of overheating and explosion!
- **Replace the battery only with the supply voltage of the slot PLC switched on.** Otherwise you risk data being lost.
- **The battery condition is not indicated by a LED.** Checking whether the battery is available or not can only be done by performing a visual inspection of the slot PLC or by reading the status word

EW07,15 / %IW1007.15 Bit 3

Bit 3 = 0 Battery not available

Bit 3 = 1 Battery available

See also volume 15 of the 907 AC 1131 description, „System Technology 90 Series“, System Technology Basic Units, 2.6.6 CS31 status word

### 2.3.3.4 Serial interface COM1

Interface standard: EIA RS-232

#### Assignment of the serial interface COM1

The pin assignment of the serial interface COM1 is as follows:

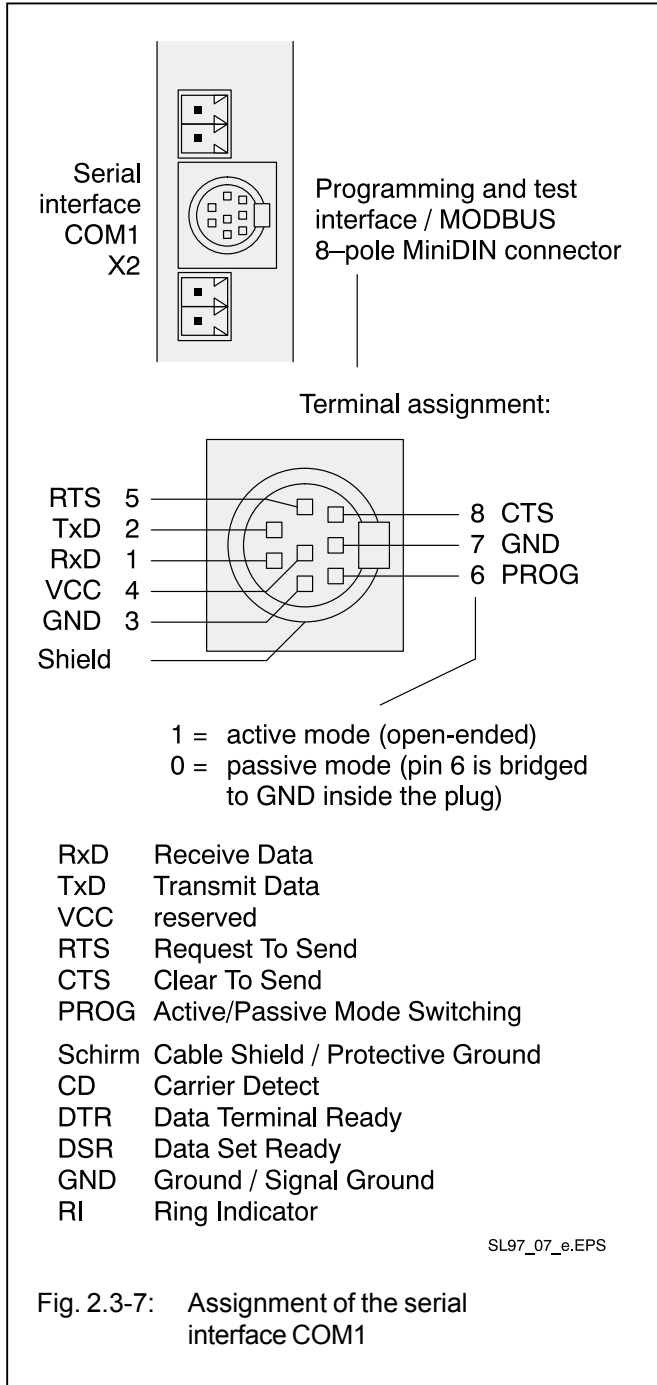

#### Interface cables for COM1

Figure 2.3-8 shows two system cables for the serial interface COM1 for active mode (programming and test) and passive mode (MODBUS).

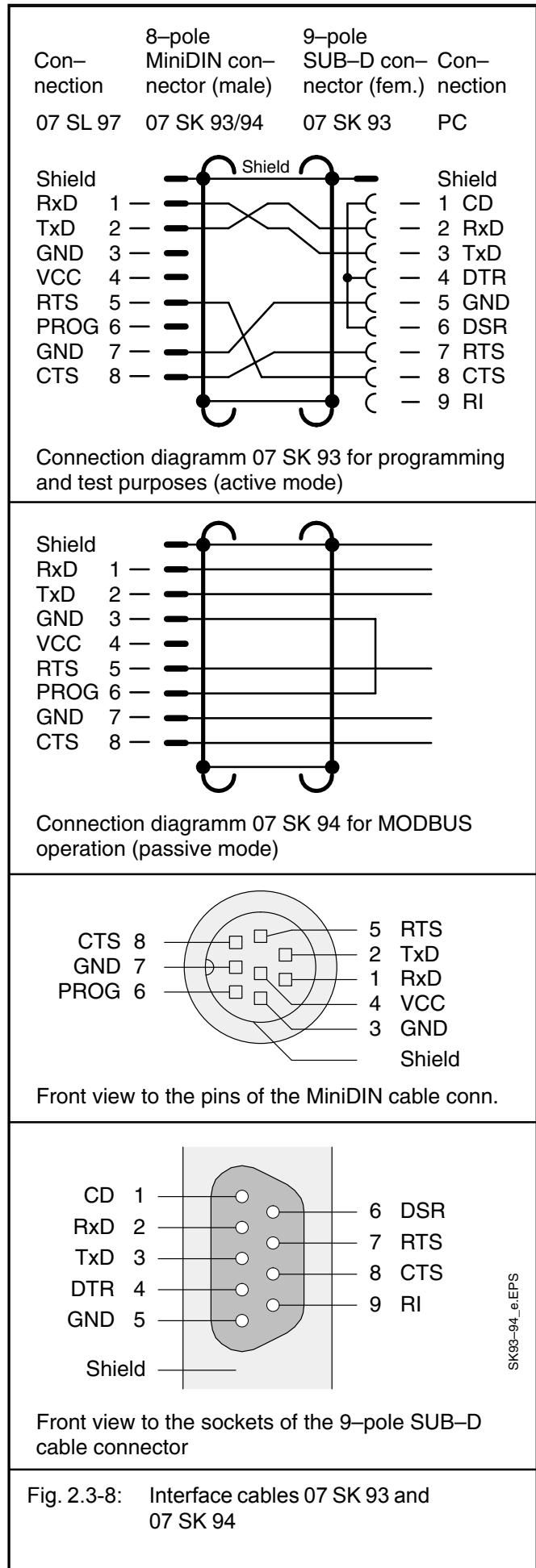

## 2.3.4 Networking / Couplers

### 2.3.4.1 Basic units with ARCNET coupler

07 SL 97 R160	Order No. GJR5 2534 00 R0160 ( ARCNET )
07 SL 97 R162	Order No. GJR5 2534 00 R0162 ( ARCNET and PROFIBUS-DP )
07 SL 97 R165	Order No. GJR5 2534 00 R0165 ( ARCNET and DeviceNet )

#### 2.3.4.1.1 Information about ARCNET

Refer to volume 15 „System Technology 90 Series“, Internal couplers, The ARCNET coupler

#### 2.3.4.1.2 ARCNET - Connection and address assignment

The ARCNET coupler is integrated in the slot PLC of the basic unit. The DIL switch for setting the ARCNET address is located near the upper edge of the board (refer to page 2.3-4). The ARCNET coupler is supplied from the internal 24 V DC power supply.

The ARCNET coupler is designed as a bus with BNC connectors for coaxial cables. The ARCNET bus is earthed inside the module by a capacitor. As an EMC measure and for protection against dangerous contact voltages, the bus has to be earthed directly at a central place.

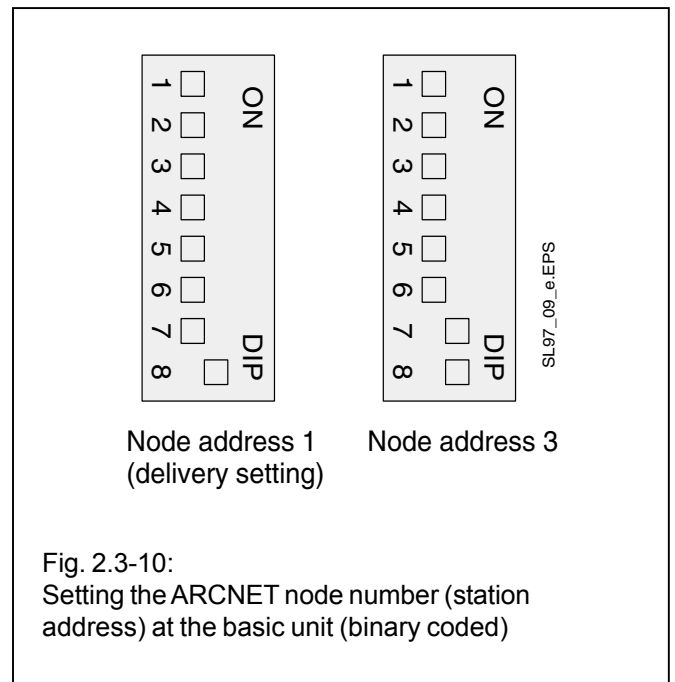
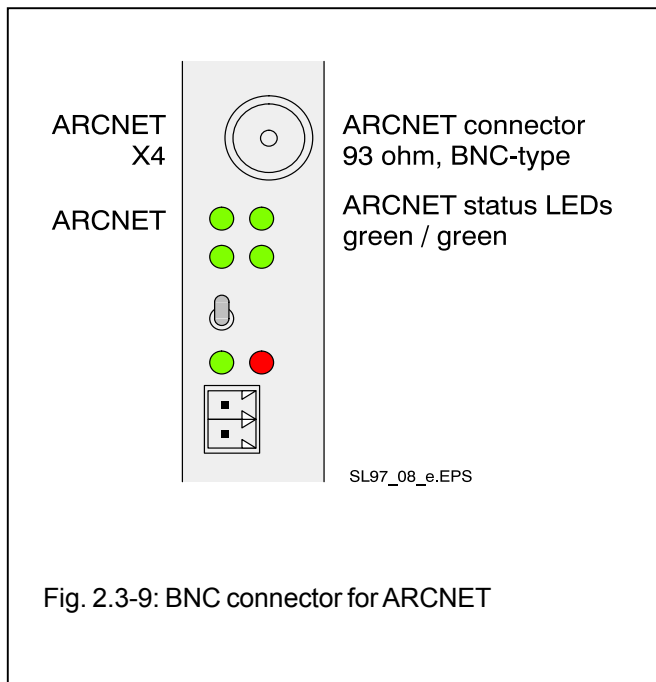

Signalling: green LED (BS)	Operating condition „controller active“, i.e. the PLC performs write or read operations
green LED (TX)	Operating condition „transmit active“, i.e. the PLC is sending via the ARCNET



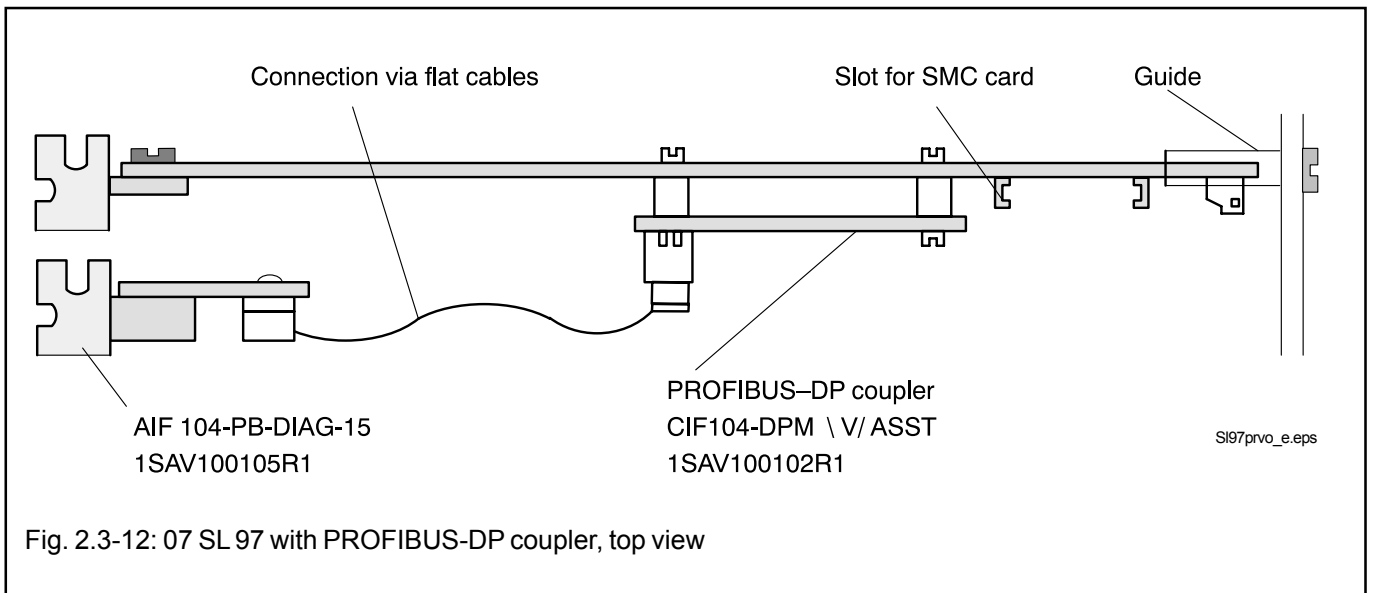

Fig. 2.3-12: 07 SL 97 with PROFIBUS-DP coupler, top view

### 2.3.4.2.3 Pin assignment, meaning of the LEDs and jumper settings

The following figure shows the pin assignment of the PROFIBUS-DP interface as well as the names of the 4 LEDs.

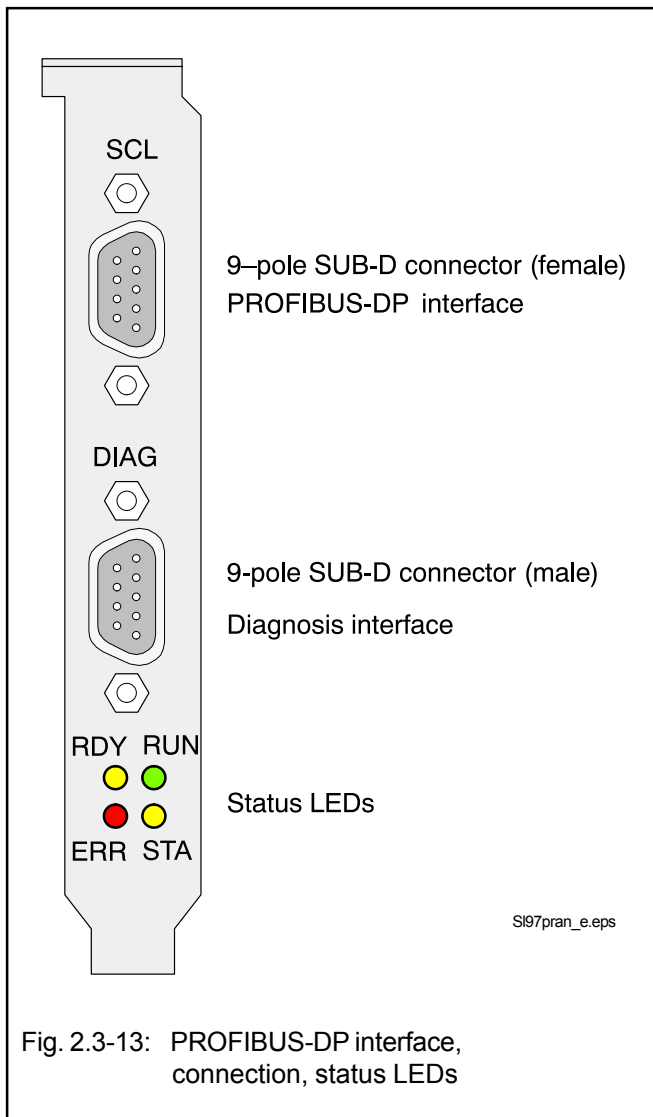

Fig. 2.3-13: PROFIBUS-DP interface, connection, status LEDs

#### Pin assignment for the PROFIBUS-DP connector

##### 9-pole SUB-D female

Pin No.	Signal	Meaning
1	Shield	Shielding, protection earth
2	Unused	
3	RxD/TxD-P	Receive/transmit line, positive
4	CNTR-P	Control signal for repeater, positive (optional)
5	DGND	Reference potential for data exchange and +5 V
6	VP	+5 V (power supply for bus terminating resistors)
7	Unused	
8	RxD/TxD-N	Receive/transmit line, negative
9	CNTR-N	Control signal for repeater, negative (optional)

#### Caution:

The 9-pole SUB-D male connector "Diagnosis interface" is intended only for service purposes and must not be wired-up from outside.

## Meaning of the LEDs

LED	Color	Status	Meaning
READY	yellow	on flashes cyclic flashes irregularly off	coupler ready bootstrap loader active hardware or system error defective hardware
RUN	green	on flashes cyclic flashes irregularly off	communication is running communication stopped missing or erroneous configuration no communication
STATUS	yellow	on off	sending data or token no token
ERROR	red	on off	PROFIBUS error no error

## Jumper settings PROFIBUS-DP

The positions of these jumpers (open-ended or plugged) must not be changed.

The following figure shows the valid settings.

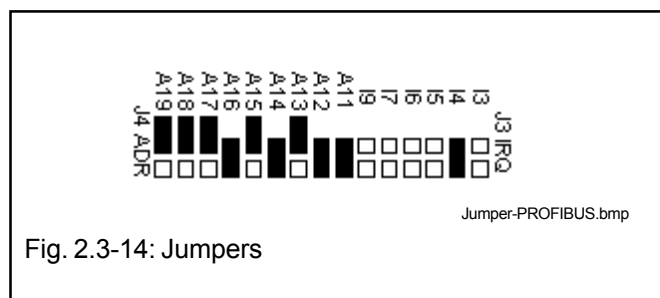

Fig. 2.3-14: Jumpers



### 2.3.4.3 Basic units with integrated DeviceNet master coupler

07 SL 97 R165

Order No. GJR5 2534 00 R0165

#### 2.3.4.3.1 Information about DeviceNet

Refer to volume 15 „System Technology 90 Series“, Internal Couplers, The DeviceNet coupler

#### 2.3.4.3.2 Installing the DeviceNet master coupler

The DeviceNet master coupler is mounted on the 07 SL 97. In order to provide the bus interface at the exterior of the PC housing the bus interface is connected to an assembly board by using a flat cable. This assembly board additionally contains 4 LEDs for indicating the coupler states.

The slot PLC 07 SL 97 together with the mounted coupler occupies two partitions inside the PC.

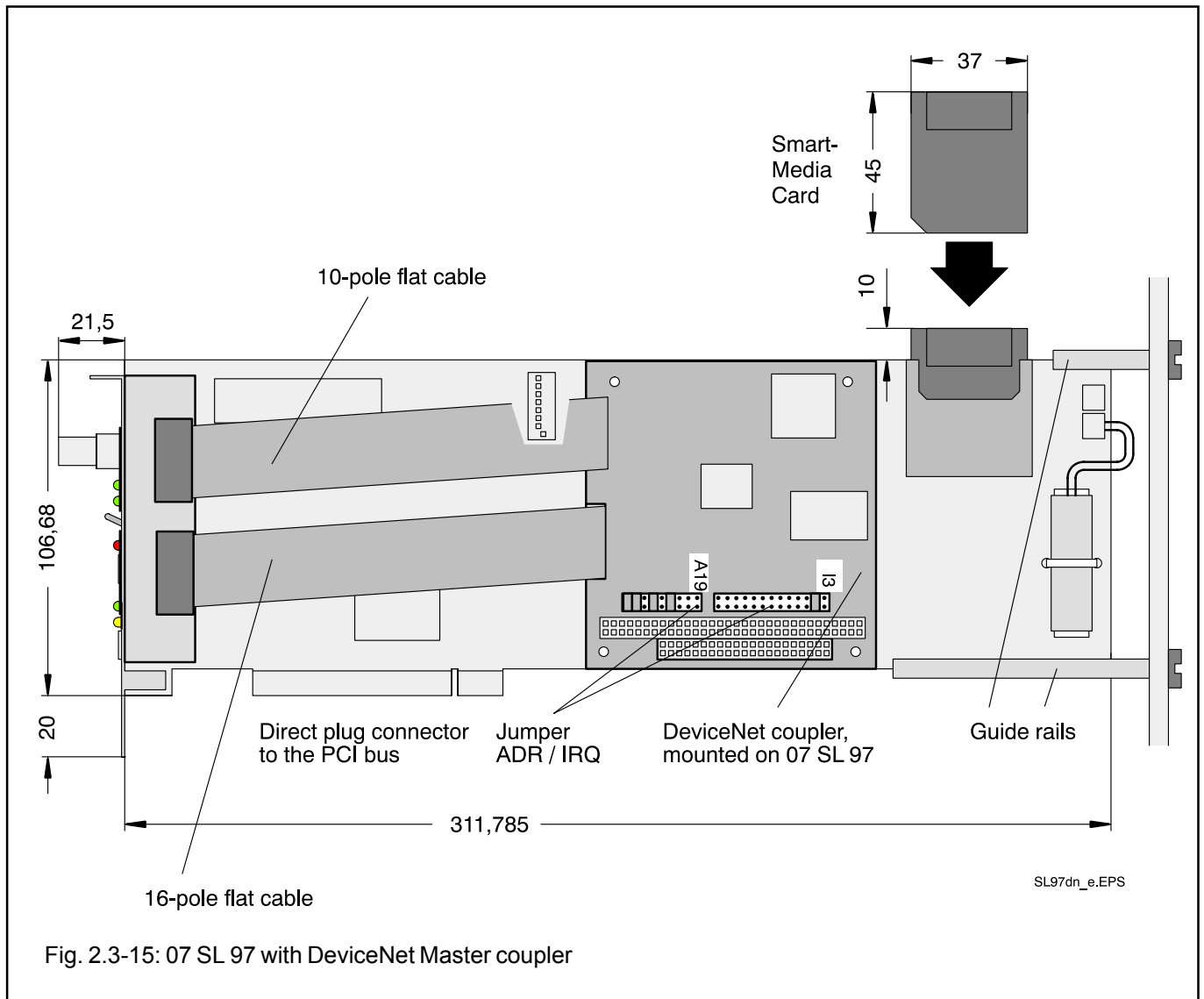

#### Caution:

**Jumpers for setting the basic address and the interrupts are located on the coupler right next to the connector for internal couplers.**

**The positions of these jumpers (open-ended or plugged) must not be changed.**

**See also section „Jumper settings“ on page 2.3-15.**

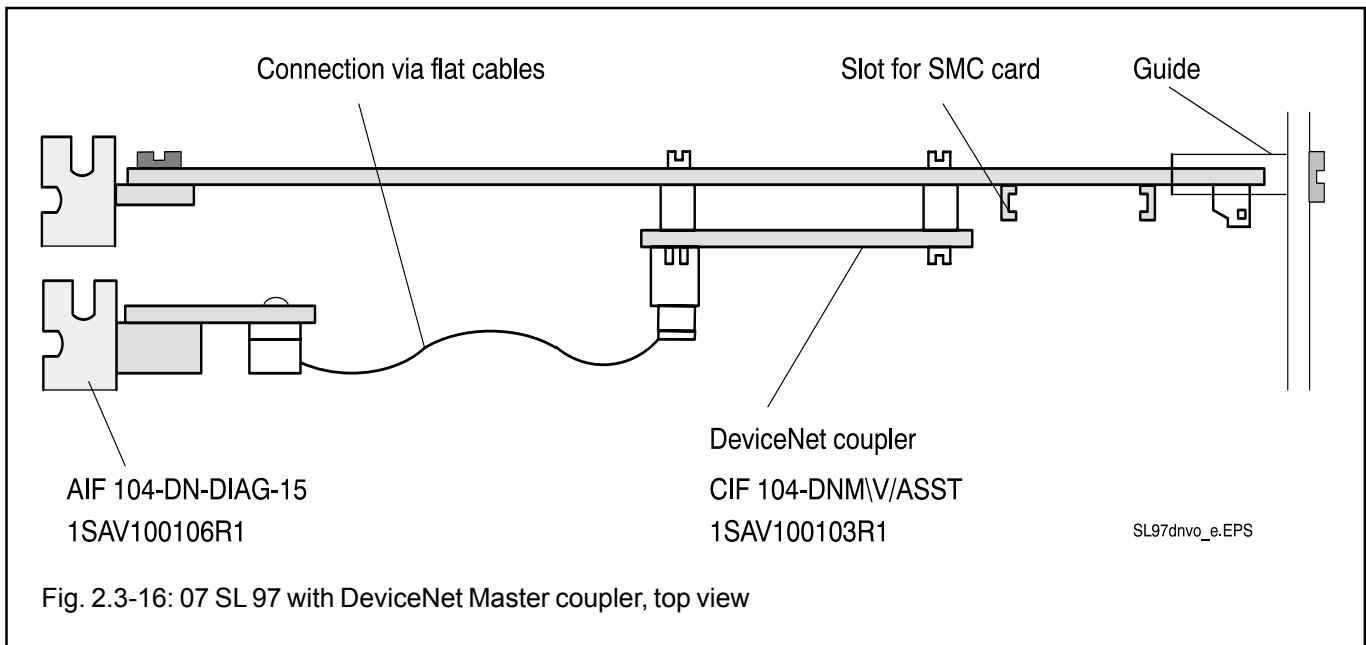

### 2.3.4.3.3 Pin assignment, meaning of the LEDs and jumper settings

The following figure shows the pin assignment of the DeviceNet interface as well as the names of the 4 LEDs.

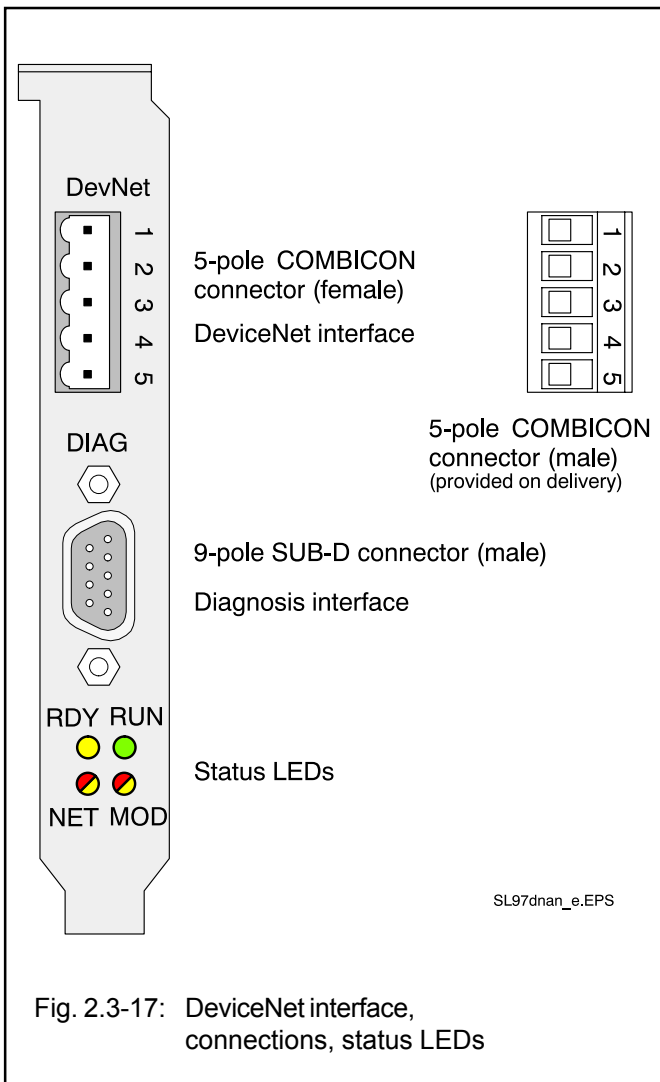

#### Pin assignment for the DeviceNet connector

##### COMBICON socket (female)

Pin No.	Signal	Meaning
1	-V	Reference potential for external power supply +24 V
2	CANL	Receive/transmit line, low
3	Shield	Shield of the bus line
4	CANH	Receive/transmit line, high
5	+V	+24 V external power supply

It is absolutely necessary that all lines (i.e. the data lines CANH / CANL, the external 24 V power supply +V / -V and the shielding) are connected.

##### Caution:

**The 9-pole SUB-D male connector on the assembly board is intended only for service purposes and must not be wired-up from outside.**

## Status LEDs

LED	Color	Status	Meaning
RDY	yellow	on flashes cyclic flashes irregularly off	coupler ready bootstrap loader active hardware or system error defective hardware
RUN	green	on flashes cyclic flashes irregularly off	communication is running communication stopped missing or erroneous configuration no communication
NET	green/red	green on flashes green off red on flashes red	connected to the bus, communication established connected to the bus, no communication no supply voltage, not connected to the bus critical connection error timing supervision error
MOD	green/red	green on flashes green off red on flashes red	coupler running coupler ready for operation no supply voltage uncorrectable error minor error

## Jumper settings DeviceNet master

The positions of these jumpers (open-ended or plugged) must not be changed.

The following figure shows the valid settings.

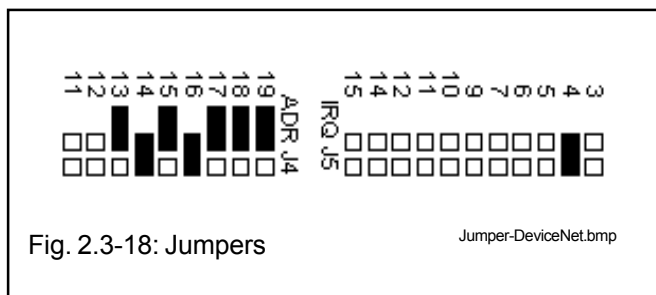

### 2.3.5 SmartMedia Card 07 MC 90

The SmartMedia Card serves for storing data up to 2 MB to protect them against being lost while the power is off. It is inserted into the basic unit 07 SL 97. It is recommended only to use ABB-proven SmartMedia Cards.

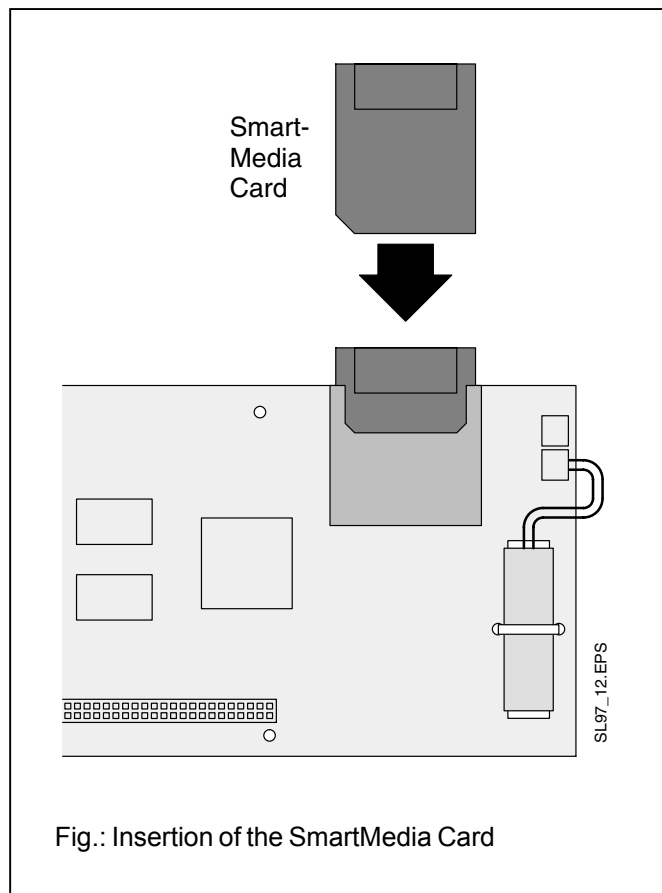

#### Field of application

- Storing and loading of PLC programs
- Storing and loading of user data
- Loading of firmware updates

#### Handling instructions

- **Observe the instructions of the PC manufacturer before opening the PC housing!**
- Insert or remove the SmartMedia Card only with the slot PLC switched off.
- The SmartMedia Card must be inserted with the contact field upwards (contacts are visible, see figure above).
- After a SmartMedia Card has been initialized once as user data memory it cannot be used any more as an user program card.
- The SmartMedia Card has to be protected against
  - mechanical damages (e.g. do not bend)
  - electrostatic discharge
  - contact pollution (do not touch the contacts)

#### Important note

SmartMedia Cards with a supply voltage of 3.3 V, e.g. GJR5 2526 **R0201**, cannot be used with 07 SL 97 basic units.

#### Access

- The SmartMedia Card can be accessed within the PLC program via function blocks. Refer to the documentation of the programming software 907 AC 1131.

#### Technical data

Weight 2 g

Dimensions 45 x 37 x 0.7 mm

Order number

07 MC 905 V 2 MB GJR5 2526 00 **R0101**

## 2.3.6 Technical data for 07 SL 97

In general, the technical system data listed under „System data and system configuration“ in chapter 1 of volume 2 of the „AC31 with 907 AC 1131“ system description are valid. Additional data or data which are different from the system data are listed below.

### 2.3.6.1 General data

Number of binary inputs	onboard, none
Number of binary outputs	onboard, none
Number of binary in-/outputs	onboard, none
Number of analog inputs	onboard, none
Number of analog outputs	onboard, none
Expansion via CS31 system bus possible up to	992 binary inputs 992 binary outputs 224 analog input channels 224 analog output channels max. 31 remote modules altogether
Number of serial interfaces	1 (for programming or connection to man-machine communication)
Number of internal interfaces	1 interface for connecting a coupler card for networking with other bus systems e.g. PROFIBUS-DP or DeviceNet
Integrated memory	Flash EPROM 512 kB (480 kB program + configuration data) RAM 2 MB (480 kB program with online programming + 256 kB variables)
Resolution of the integrated real-time clock	1 second
Processing time, 65 % bits, 35 % words	typ. 0.3 ms/kB program
Number of software timers	any
delay time of the timers	1 ms...24.8 days
Number of up/down counter software blocks	any
Number of bit flags in the addressable flag area	8192
Number of word flags	8192
Number of double word flags	1024
Number of step chains	256
Number of constants KW	1440
Number of constants KD	384
Indication of operating states and errors	6 LEDs altogether
Wiring method	detachable screw-type terminal blocks
supply terminals, CS31 system bus	2 x 0.08 mm <sup>2</sup> - 1.5 mm <sup>2</sup> AWG 28-16
Phoenix-type terminals	line cross section 0.08 - 1.5 mm <sup>2</sup> rigid / flexible
item no. 18 40366 MC 1,5/ 2-ST-3.81	AWG 28-16

### 2.3.6.2 Power supply

Rated supply voltage	24 V DC
Current consumption at nominal voltage	max. 0.21 A
Protection against reversed polarity	yes

### 2.3.6.3 Lithium battery

Battery for backup of RAM data  
Lifetime at 25 °C

battery module 07 LE 90  
typ. 5 years

### 2.3.6.4 Connection of the serial interface COM1

Interface standard

EIA RS-232

Programming using 907 AC 1131

with IBM PC (or compatible)

Programming modifications using 907 AC 1131

with IBM PC (or compatible)

Man-Machine Communication

yes, e.g. with operating station

Electrical isolation

against CS31 system bus interface

Potential differences

In order to avoid potential differences between the 07 SL 97 basic unit and the peripheral devices connected to COM1, these devices are supplied by the same socket in the control cabinet.

Terminal assignment and description  
of the interface COM 1

refer to chapter 2.3.3.4

### 2.3.6.5 Connection to the CS31 system bus

Interface standard

EIA RS-485

Connection as a master PLC  
as a slave PLC

yes, transmit and receive areas are configurable  
yes, see „System constants“

Setting of the CS31 module address

yes, by system constant, stored in the  
Flash EPROM of the slave PLC

Electrical isolation

against supply voltage, inputs and outputs,  
against interface COM1

Terminal assignment and description  
of the CS31 system bus interface

refer to chapter 2.3.3.2

### 2.3.6.6 PCI interface

According to PCI interface specification V2.1  
32 bit bus / 33 MHz

Self-configuring full-size PCI card, designed in 5 V  
technology

PCI interface realized using PLX chip

8 k memory range on PCI bus

Interrupt processing as PCI target

Interrupt setting depending on the PC

### 2.3.6.7 Connection to ARCNET

Coaxial cable of the type RG62/U, 93 Ω

data transfer rate 2.5 Mbits/s

Coaxial connector suitable for the coaxial cable

### 2.3.6.8 LED displays

LEDs for signalling:

- supply voltage available (Supply)
- program is running (RUN)
- controller-specific errors (FK1, FK2, FK3)
- CS31 bus initialized (BA)
- ARCNET status LED

- 1 green LED
- 1 green LED
- sum error message 1 red LED
- sum error message 1 green LED
- 2 green LEDs

### 2.3.6.9 Mechanical data

Fastening in PCI direct plug connector

Fastening by screws

Board size width x height x depth

Board size width x height x depth

Wiring method

- supply terminals, CS31 system bus
- all other terminals

Combicon-type terminals

item no. 189 4244 MC 1,5/ 2-ST-3.81 Gy

Weight

Dimensions for mounting

to the PC housing using 1 M4 screw

311.78 x 106.68 x 19 mm (without board holder)

311.78 x 126.68 x 19 mm (with board holder)

detachable screw-type terminal blocks

max. 0.08 - 1.5 mm<sup>2</sup>

max. 0.08 - 1.5 mm<sup>2</sup>

line cross section 0.08 - 1.5 mm<sup>2</sup> rigid / flexible

AWG 28-16

1.0 kg

refer to the following figure

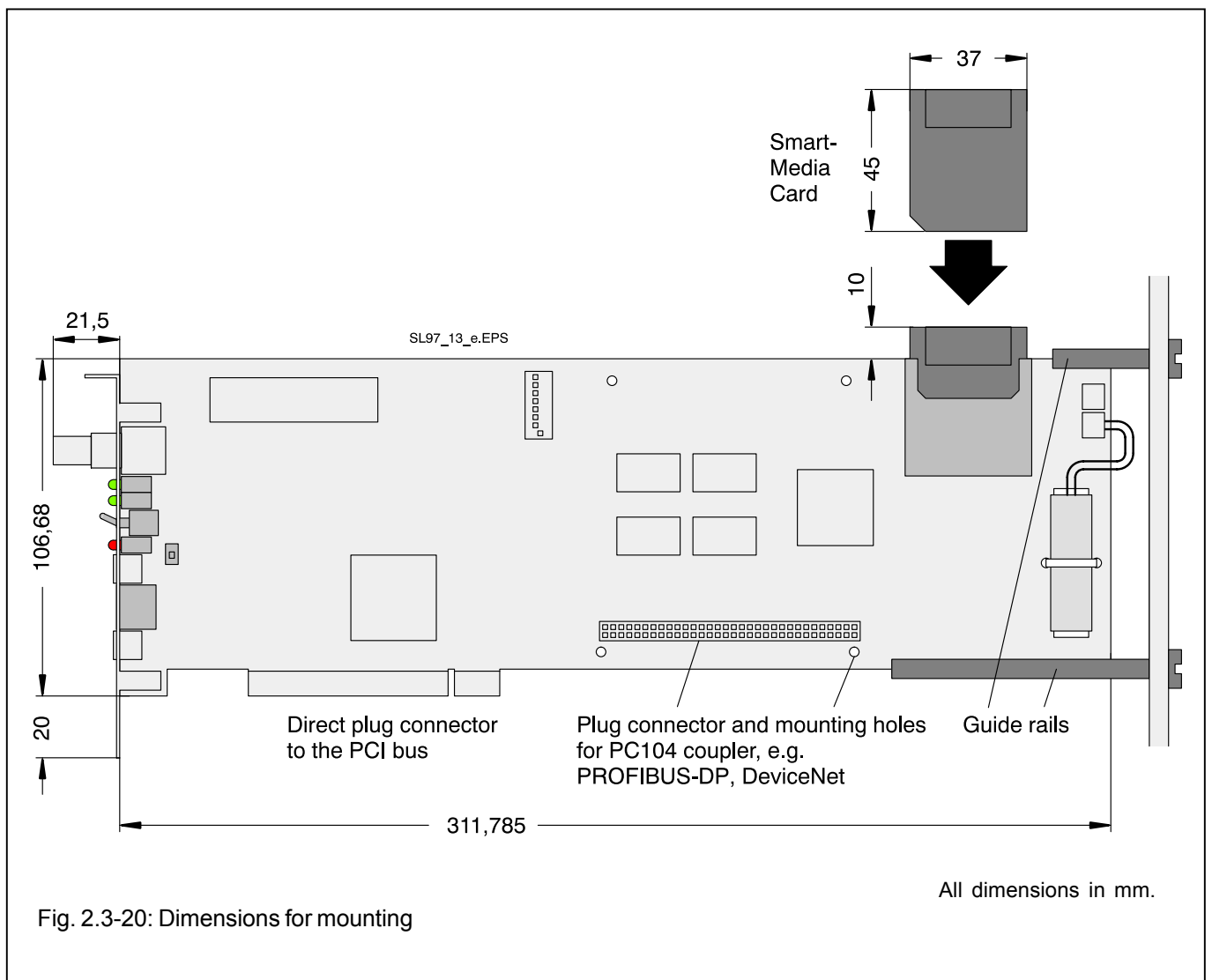

### 2.3.6.10 Mounting hints

Mounting position

vertically, terminals on the left or on the right hand side

Vibration and shock resistance

To obtain the specified vibration and shock resistance the board edge opposite to the terminals has to be fixed to the PC housing by means of guide rails. The guide rails are provided as an accessory with the PC.

Cooling

The natural convection cooling must not be hindered by other mounted material.

### 2.3.6.11 Ordering data

Basic unit **07 SL 97 R0160 (ARCNET)**

**Order No. GJR5 2534 00 R0160**

Scope of delivery

Basic unit 07 SL 97 R0160

2 x 2-pole terminal block (3.81 mm grid space)

Basic unit **07 SL 97 R0162  
(ARCNET with PROFIBUS-DP)**

**Order No. GJR5 2534 00 R0162**

Scope of delivery

Basic unit 07 SL 97 R0162

with integrated PROFIBUS-DP coupler

2 x 2-pole terminal block (3.81 mm grid space)

Basic unit **07 SL 97 R0165 (ARCNET with DeviceNet)**

**Order No. GJR5 2534 00 R0165**

Scope of delivery

Basic unit 07 SL 97 R0165

with integrated DeviceNet coupler

2 x 2-pole terminal block (3.81 mm grid space)

PC programming cable 07 SK 93  
MODBUS/ASCII communication cable 07 SK 94  
Battery module 07 LE 90  
SmartMedia Card 07 MC 90 5 V 2 MB

**Order No. GJR5 2535 00 R0001**

**Order No. GJR5 2536 00 R0001**

**Order No. GJR5 2507 00 R0001**

**Order No. GJR5 2526 00 R0101**







---

**ABB STOTZ-KONTAKT GmbH**

Eppelheimer Straße 82    Postfach 101680  
69123 Heidelberg        69006 Heidelberg  
Germany                    Germany

Telephone    +49 6221 701-0  
Telefax        +49 6221 701-240  
E-Mail         desst.help@de.abb.com  
Internet        <http://www.abb.de/stotz-kontakt>

# 3 Plug-in bases

---

3.1 Plug-in base ECZ ..... 3.1-1



## 3.1 Plug-in base ECZ

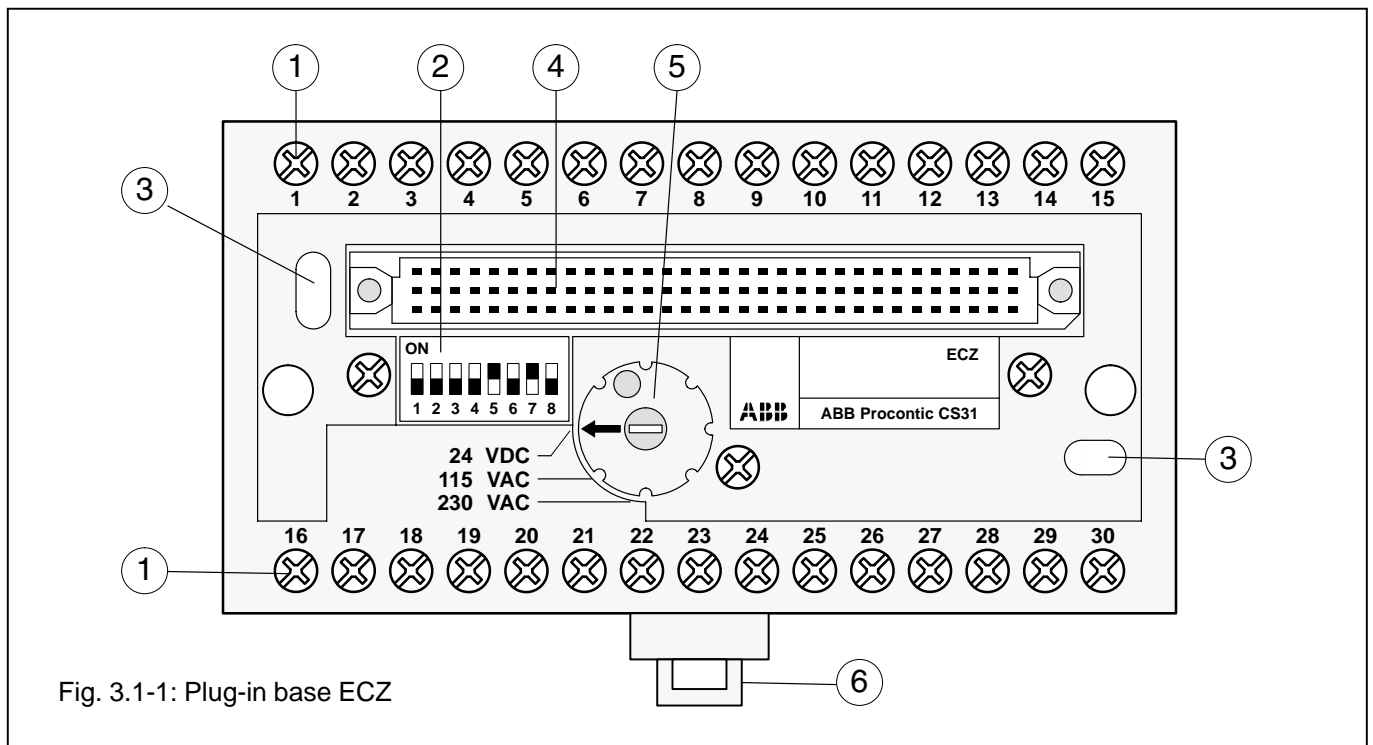

Fig. 3.1-1: Plug-in base ECZ

- (1) Terminals (1-30)
- (2) DIL switch for setting the module address
- (3) Two bore holes for mounting on a surface
- (4) DIN plug (96-pole) for the electrical connection with the remote modules
- (5) Rotary wheel for mechanical coding of the supply voltage (24 V DC, 115 V AC, 230 V AC). Prevents that a module can be plugged-in with another supply voltage than set on the ECZ.
- (6) Adaptor for mounting the plug-in base onto a DIN rail.

The plug-in base ECZ is used for CS31 remote modules as well as for the basic units PCZB and CS20. For the digital input module ICSI 16 L1, two plug-in bases are necessary.

The remote modules are put on the plug-in base and then fastened with two screws. The screws belong to the remote modules. They can be reached from the front panel.

The electric wiring is performed via the terminals 1 to 30 of the plug-in base. In this way, remote modules can be replaced without loosening wires.

### 3.1.1 Technical data

Terminals  
Weight  
Order No.

Independent of which type of module is mounted, the terminals 1, 2, 3, 16, 17 and 18 always have the same allocation:

Terminal 1: Bus 2  
Terminal 2: Bus 1  
Terminal 3: Shield (system bus)  
Terminal 16: Supply voltage +24 V DC or 230 V AC  
Terminal 17: Supply voltage 0 V or AC  
Terminal 18: Earthing

In order to protect the remote modules from electrical interferences, the terminals for the supply voltage are equipped with a filter circuitry. The components (L, C) are integrated in the plug-in base.

The assignment of the other terminals depends on the module type put on the plug-in base (see module descriptions).

Remote modules can be replaced without switching off the power supply.

Wiring of the 2-wire bus: All terminals No. 2 (BUS 1) of the plug-in bases have to be connected with the BUS1 terminal of the basic unit. All terminals No. 1 (BUS2) of the plug-in bases have to be connected with the BUS2 terminal of the basic unit.

conductor cross section max. 2 x 2.5 mm<sup>2</sup>  
200 g  
FPR3700001R0001



## 4 Digital input and output modules

---

4.1	<b>07 DI 92:</b>	Digital input module, 32 inputs 24 V DC, electrically isolated in groups .....	4.1-1
4.2	<b>ICSI 08 E4:</b>	Digital input module, 8 inputs 230 V AC, electrically isolated .....	4.2-1
4.4	<b>ICSO 08 R1:</b>	Digital output module, 8 relay outputs 2 A, electrically isolated .....	4.4-1
4.5	<b>ICSO 08 Y1:</b>	Digital output module, 8 outputs 24 V DC, 2 A, electrically isolated .....	4.5-1
4.7	<b>07 DC 91:</b>	Digital I/O module, 16 inputs, 8 outputs, 8 configurable I/Os, 24 V DC .....	4.7-1
4.8	<b>07 DC 92:</b>	Digital I/O module, 32 configurable I/Os, 24 V DC, output load max. 500 mA .....	4.8-1
4.10	<b>07 TC 91:</b>	Keyboard controller 07 TC 91, 32 switches/keys and 32 LEDs controllable .....	4.10-1
4.12	<b>07 DI 93-I:</b>	Digital input module, 16 channels 24 V DC, degree of protection IP67 .....	4.12-1
4.13	<b>07 DO 93-I:</b>	Digital output module, 8 channels 24 V DC, 2 A, degree of protection IP67 .....	4.13-1
4.14	<b>07 DK 93-I:</b>	Digital I/O module, 8 input channels 24 V DC, 4 output channels 24 V DC/2 A, degree of protection IP67 .....	4.14-1





## 4.1 Digital Input Module 07 DI 92

32 digital inputs 24 V DC, electrically isolated in groups,  
CS31 system bus

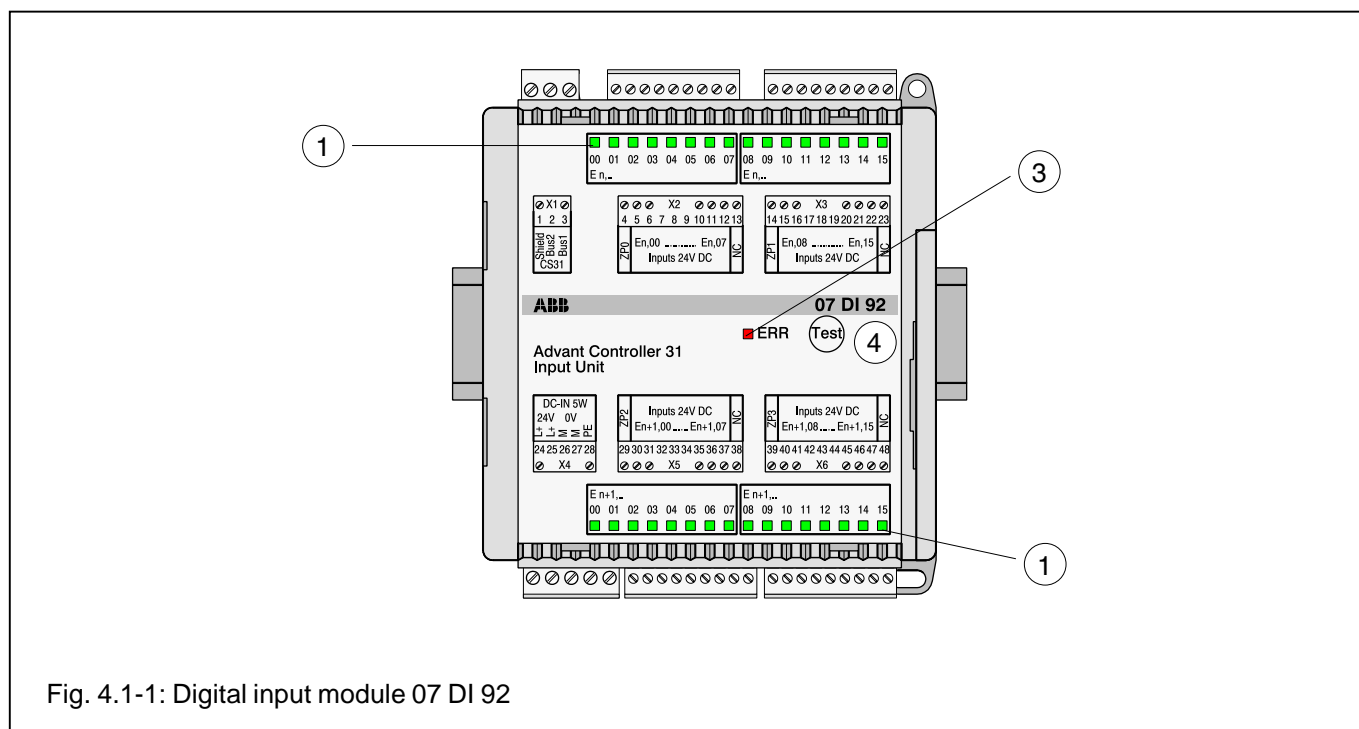

### Contents

Intended purpose .....	4.1-1
Display and operating elements on the front panel .....	4.1-1
Electrical connection .....	4.1-1
Addressing .....	4.1-3
Input/output configuration .....	4.1-3
Normal operation .....	4.1-3
Displays .....	4.1-3
Technical data .....	4.1-4
Dimensions for installation .....	4.1-6

### Intended purpose

The digital input module 07 DI 92 is used as a remote module on the CS31 system bus. It contains 32 inputs, 24 V DC, in 4 groups with the following features:

- The 4 groups of the inputs are electrically isolated from each other and from the rest of the unit.

- The module occupies two digital addresses for inputs on the CS31 system bus.

The unit works with a supply voltage of 24 V DC.

The system bus connection is electrically isolated from the rest of the unit.

### Display and operating elements on the front panel

- 32 green LEDs to indicate the signal status of the inputs
- Red LED for error messages
- Test button

### Electrical connection

The module can be mounted on a DIN rail (15 mm high) or with 4 screws. The following illustration shows the electrical connection of the input module.

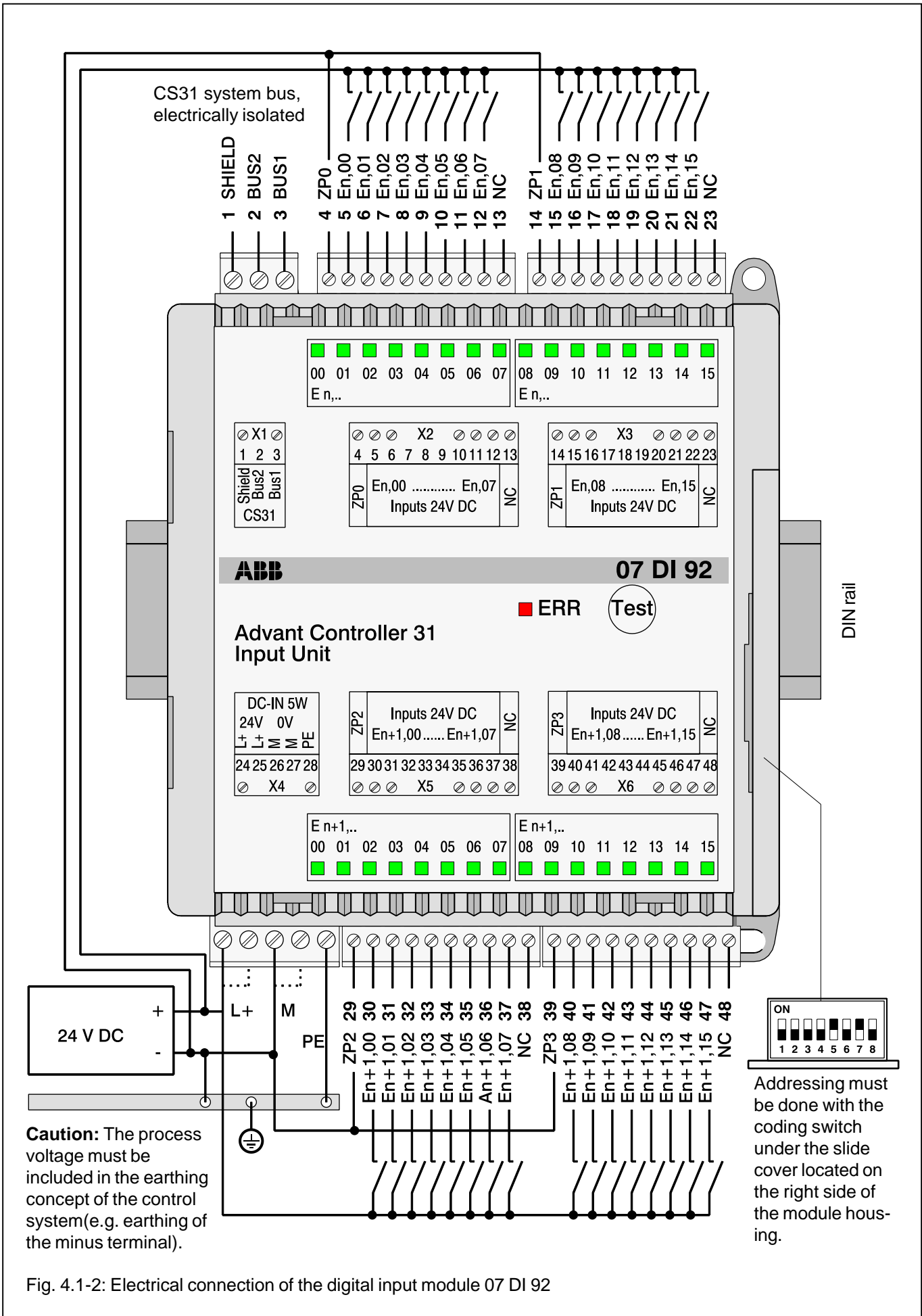

Fig. 4.1-2: Electrical connection of the digital input module 07 DI 92

## Addressing

An address must be set for each module to enable the basic unit to correctly access the inputs and outputs.

**A detailed description about "Addressing" can be found in the chapter "Addressing" of the basic units and couplers.**

The address setting is accomplished with the DIL switch located under the slide cover on the right side of the module housing.

When using basic units 07 KR 91, 07 KT 92 to 07 KT 97 as bus master, the following address assignments apply:

Basic units 07 KR 91 / 07 KT 92 to 97			
Terminal	Input	Terminal	Input
5	E n,00	30	E n+1,00
6	E n,01	31	E n+1,01
7	E n,02	32	E n+1,02
8	E n,03	33	E n+1,03
9	E n,04	34	E n+1,04
10	E n,05	35	E n+1,05
11	E n,06	36	E n+1,06
12	E n,07	37	E n+1,07
15	E n,08	40	E n+1,08
16	E n,09	41	E n+1,09
17	E n,10	42	E n+1,10
18	E n,11	43	E n+1,11
19	E n,12	44	E n+1,12
20	E n,13	45	E n+1,13
21	E n,14	46	E n+1,14
22	E n,15	47	E n+1,15

n: Module address, can be set with address DIL switch with switches 2...7.  
 Recommended module addresses for 07 KR 91 / 07 KT 92 to 97 as bus master: 08, 10, 12...60 (even-numbered addresses)

The module occupies **two** addresses on the CS31 system bus for inputs.  
 Switches 1 and 8 of the address DIL switch must be set to OFF.

Fig 4.1-3: Addresses of the channels

Note:

Module 07 DI 92 reads the position of the address switch **only** during the initialization after the power was switched on, which means, that changes of the setting during operation will remain ineffective until the next initialization.

## Input/output configuration

No configuration data are required for the 07 DI 92.

## Normal operation

- The module automatically initializes after the power has been switched on. During that time, all LEDs are switched on.
- When the CS31 system bus does not run, LED ③ flashes
- The LED ③ goes out again after the system bus runs correctly and the unit does not detect any error.
- The 32 green LEDs ① show the signal status of the 32 inputs.

## Displays

By pressing the test button, an LED test is initiated. All LEDs must light up. Following that, the position of the address switch is displayed for about 3 seconds by LEDs 00 to 07 which was set by module 07 DI 92 during the initialization. In this case LED 00 shows the setting of switch 1 (LEDs 0...7 are assigned to switches 1...8).

## Technical data 07 DI 92

In general, the technical system data listed under "System data and system configuration" in chapter 1 of volume 2 of the Advant Controller 31 system description are valid. Additional data or data which are different from the system data are listed as follows.

### Technical data for the complete unit

Permissible temperature range during operation	0...55 °C
Rated supply voltage	24 V DC
Nominal signal voltage at inputs	24 V DC
Max. current consumption	0.15 A
Max. nominal load capacity for supply terminals	4.0 A
Max. power dissipation inside the unit	10 W
Protection against incorrect polarity of supply voltage	yes
Conductor cross section for removable connectors	
power supply	max. 2.5 mm <sup>2</sup>
CS31 system bus	max. 2.5 mm <sup>2</sup>
signal terminals	max. 1.5 mm <sup>2</sup>
reference potentials ZP0, ZP1, ZP2, ZP3	max. 1.5 mm <sup>2</sup>
Number of inputs	32
Electrical isolation CS31 system bus inputs	from the rest of the unit group from group, all groups from the rest of the unit
Reference potential for inputs	each group has a separate reference potential see Fig. 4.1-2
Number of interfaces	1 CS31 system bus interface
Address setting	Coding switch under the cover located on the right side of the housing
Operation and error displays	a total of 33 LEDs

### Technical data for the digital inputs

Number of channels per module	32
Division of channels into groups	4 groups with 8 channels each, channels En,00...En,07 and En,08...En,15 channels En+1,00...En+1,07 and En+1,08...En+1,15
Reference potentials for the inputs	ZP0, ZP1, ZP2 and ZP3
Electrical isolation	group from group, all groups from the rest of the unit
Input signal delay	typ. 7 ms
Signalization of the input signals	one green LED per channel, LEDs activated according to the input signal
Input signal voltage	24 V DC
0 signal	- 30 V...+ 5 V
1 signal	+ 13 V...+ 30 V
residual ripple for 0 signal	within - 30 V...+ 5 V
for 1 signal	within + 13 V...+ 30 V

Input current per channel	
input voltage = + 24 V	typ. 7.0 mA
input voltage = + 5 V	≥ 0.2 mA
input voltage = + 13 V	≥ 2.0 mA
input voltage = + 30 V	≤ 9.0 mA
Conductor cross section for the removable terminal blocks	max. 1.5 mm <sup>2</sup> (distance between terminals 3.81 mm)
<b>Connection to the CS31 system bus</b>	
Interface standard	EIA RS-485
Electrical isolation	against supply voltage, inputs and outputs
Conductor cross section for the removable terminal blocks	max. 2.5 mm <sup>2</sup> (grid space 5.08 mm)
<b>Mechanical data</b>	
Mounting and DIN rail	according to DIN EN 50022–35, 15 mm deep. The DIN rail is centrally positioned between upper and lower edge of the module.
Mounting with screws	4 screws M4
Width x height x depth	120 x 140 x 85 mm
Connection method cross section	removable connectors with screw-type terminals max. 2.5 mm <sup>2</sup> (grid space 5.08 mm) max. 1.5 mm <sup>2</sup> (grid space 3.81 mm)
Weight	450 g
Dimensions for installation	see illustration on next page
<b>Installation instructions</b>	
Mounting position	vertical, connectors must point upward and downward
Cooling	The natural convection cooling must not be obstructed by cable ducts or other components in the cabinet
<b>Ordering data</b>	
Module 07 DI 92	Order No. GJR5 2524 00 R0101
Scope of delivery	Digital input module 07 DI 92 1 5-pin connector (grid space 5.08 mm) 1 3-pin connector (grid space 5.08 mm) 4 10-pin connectors (grid space 3.81 mm)

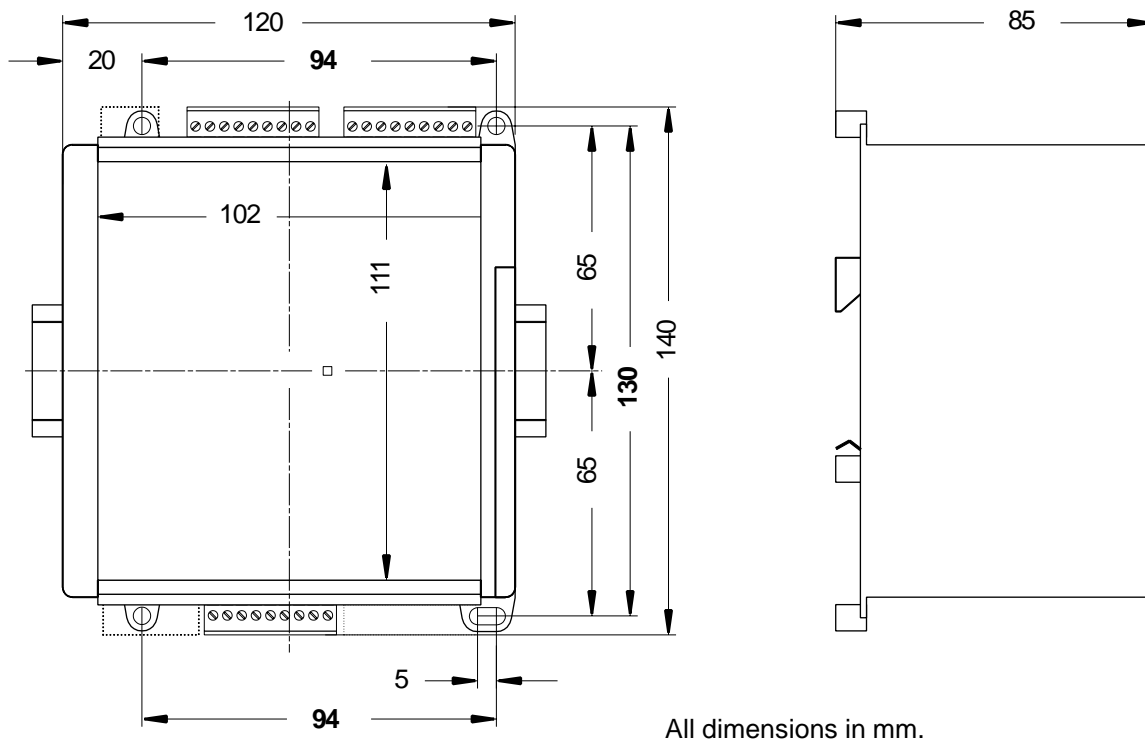
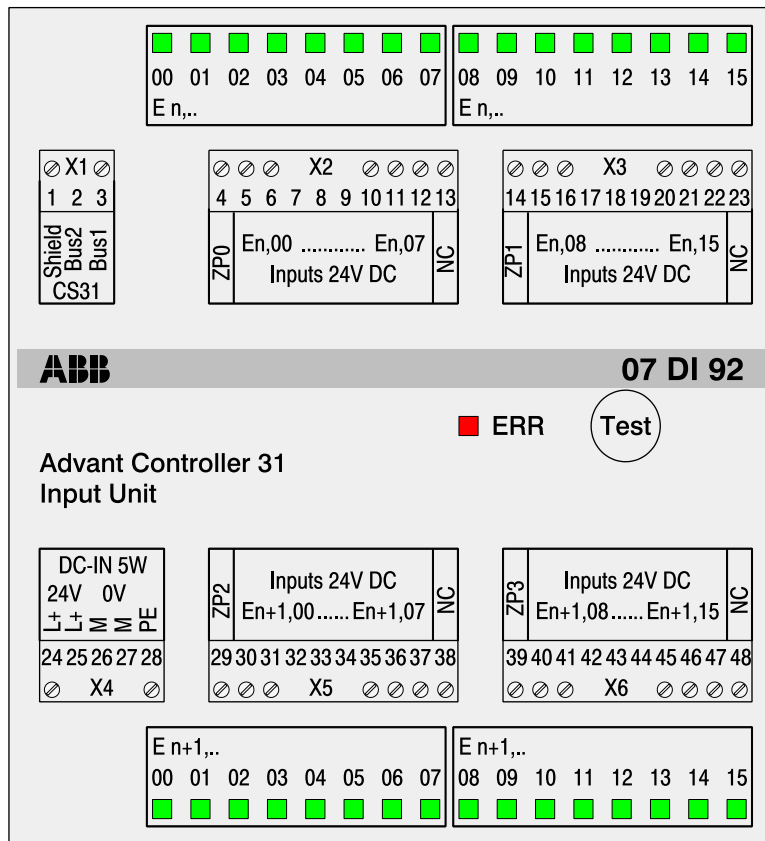

All dimensions in mm.

**The depth of the unit is 85 mm.** If a DIN rail is used for the installation, the installation depth increases by the depth of the DIN rail.

Fig. 4.1-4: 07 DI 92, Front panel and outline dimensions  
**Dimensions for the installation holes are shown in bold print**

## 4.2 Digital input module ICSI 08 E4

8 input channels 230 V AC, electrically isolated  
CS31 system bus interface electrically isolated

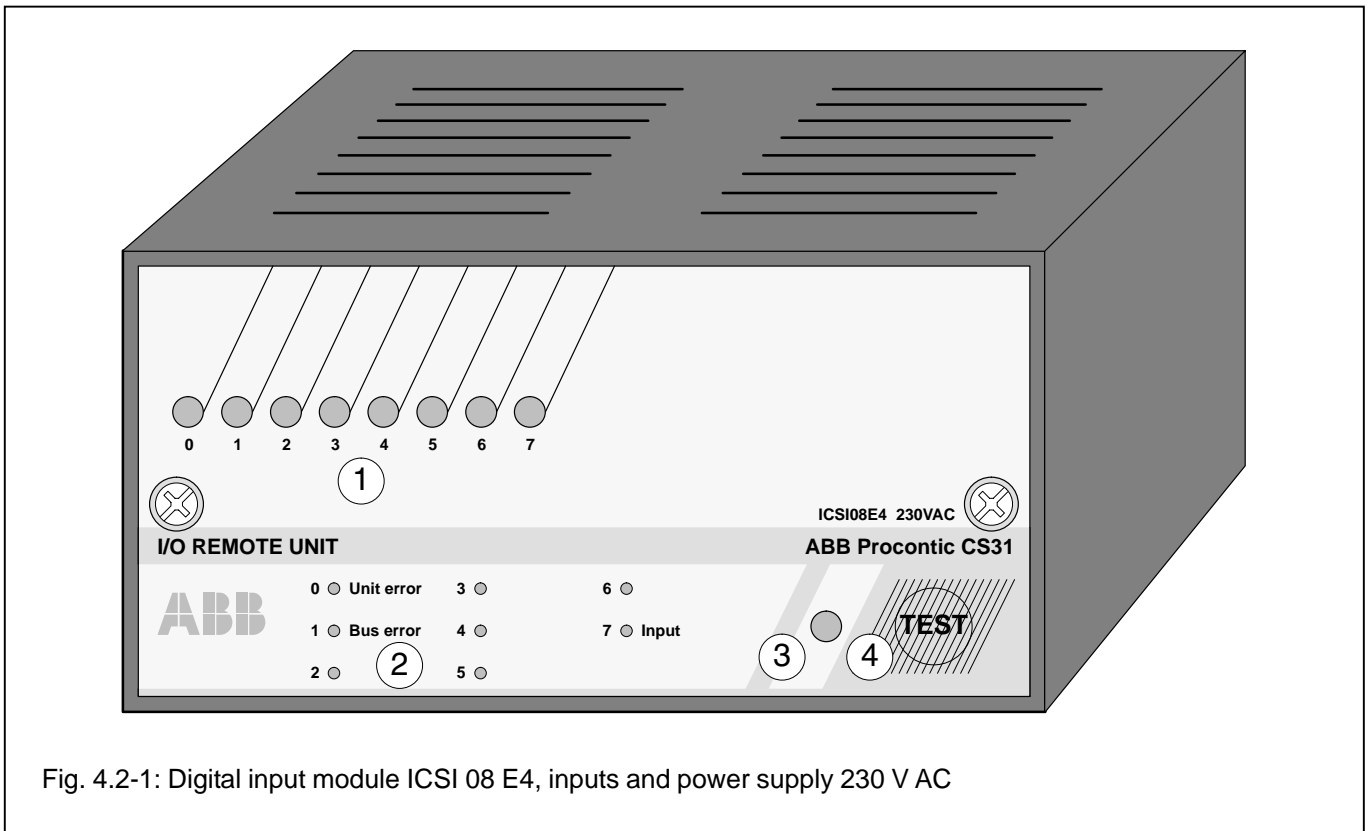

Fig. 4.2-1: Digital input module ICSI 08 E4, inputs and power supply 230 V AC

### Contents

Intended purpose .....	4.2-1
Display and operating elements on the front panel .....	4.2-1
Electrical connection .....	4.2-1
Addressing .....	4.2-3
I/O configuration .....	4.2-3
Normal operation .....	4.2-3
Diagnosis and displays .....	4.2-3
Technical data .....	4.2-4
Dimensions for installation .....	4.2-5

### Intended purpose

The digital input module ICSI 08 E4 is used as a remote module on the CS31 system bus. It contains 8 **electrically isolated** input channels for a rated voltage of 230 V AC. The signal statuses of the input signals is indicated with 8 yellow LEDs on the front panel.

The module is powered by a supply voltage of 230 V AC. It is electrically isolated from the mains voltage. For electrical connection, it has to be mounted on a plug-in base ECZ.

The CS31 system bus interface is electrically isolated from the rest of the module.

The module offers a number of diagnosis functions (see chapter "Diagnosis and displays").

### Display and operating elements on the front panel

- ① 8 yellow LEDs to indicate the signal status of the inputs or for displaying error and diagnosis data
- ② List of diagnosis information concerning the LEDs when they are used for diagnosis display
- ③ Red LED for error message
- ④ Test button

### Electrical connection

The module has to be mounted on the plug-in base ECZ and then fastened with two screws. The plug-in base has a mechanical coding which prevents that a module can be plugged-in with another supply voltage than set on the ECZ. Before mounting the input module, the mechanical coding has to be set to the correct supply voltage.

The following figure shows the electrical connection of the input module.

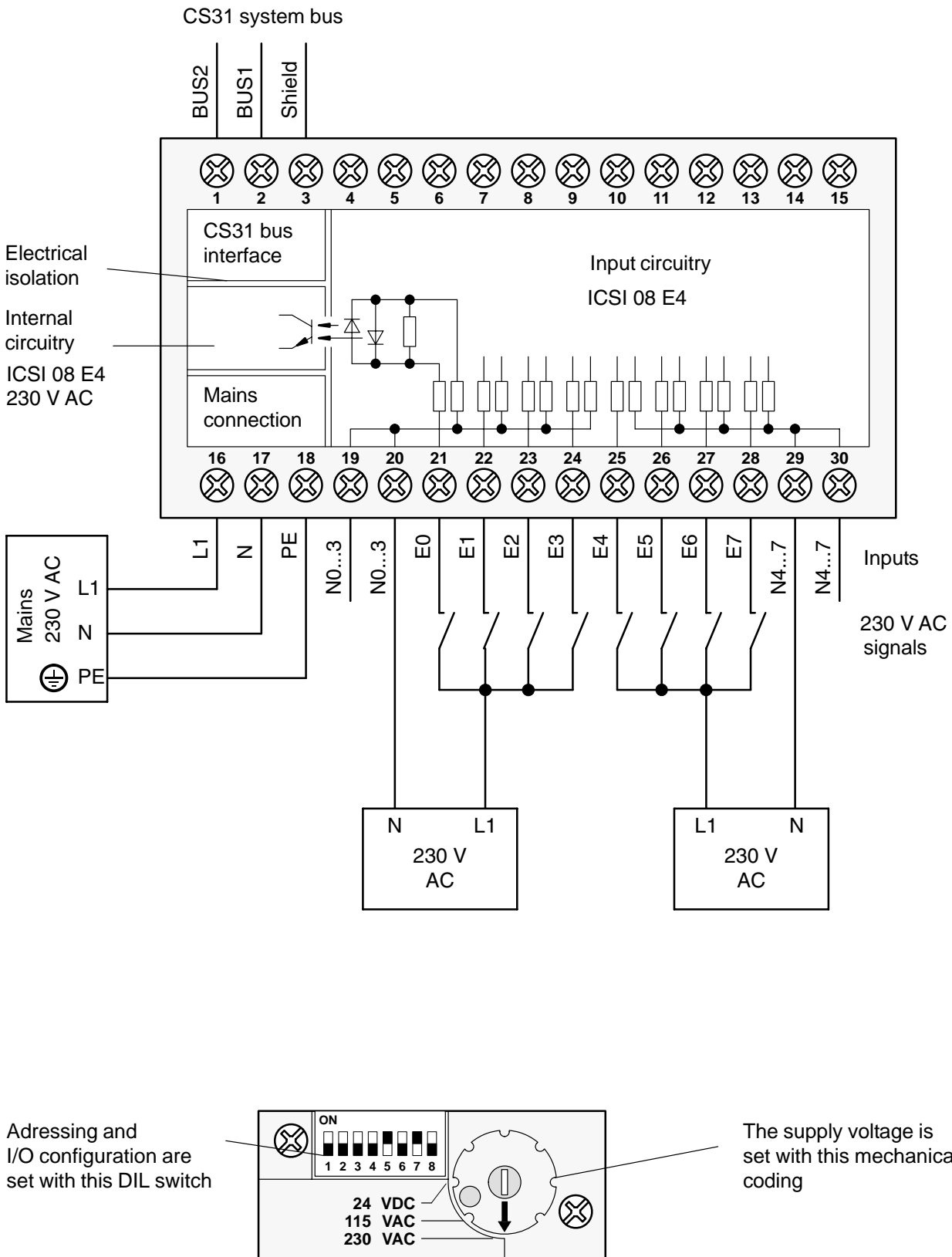

Fig. 4.2-2: Electrical connection of the digital input module ICSI 08 E4, supply voltage 230 V AC



## Addressing

An address must be set for each module to enable the basic unit to correctly access the inputs.

**A detailed description about "Addressing" can be found in the chapter "Addressing" of the basic units and couplers.**

The address setting is accomplished with the DIL switch on the plug-in base ECZ. When using the basic units 07 KR 91 and 07 KT 9x as bus masters, the following address assignments are valid:

Basic unit	07 KR 91 / 07 KT 9x	
DIL switch No. 8 on the ECZ	OFF (recommended)	ON
Channel		
E0	E xx,00	E xx,08
E1	E xx,01	E xx,09
E2	E xx,02	E xx,10
E3	E xx,03	E xx,11
E4	E xx,04	E xx,12
E5	E xx,05	E xx,13
E6	E xx,06	E xx,14
E7	E xx,07	E xx,15
xx: Group number of the address, set on the DIL switch of the plug-in base with the switches 2...7. Recommended addresses with 07 KR 91 / 07 KT 9x as bus masters: 08, 10, 12...60 (even-numbered addresses)		

The module uses 8 inputs on the CS31 system bus.

## I/O configuration

An I/O configuration is only necessary, if the application needs other settings than the factory settings.

The following functions can be configured:

- Alteration of the input signal delay

As factory setting both the ON delay and the OFF delay of the inputs are 10 ms. A change to values of 2...32 ms is possible via the CS31 system bus. After setting via the system bus, the real delay is 10 ms longer than the set value.

I/O configuration data, which was set via the CS31 system bus, are stored in the module even after power OFF/ON.

Using the test button, the set configuration of all channels can be individually interrogated (see chapter "Diagnosis and displays").

**For detailed descriptions about methodology of the I/O configuration via the CS31 system bus see the chapters "I/O configuration" of the used basic units and couplers.**

## Normal operation

- After power ON the module initializes automatically. During this period the red LED (3) flashes.
- After initialization the red LED (3) goes out, if the bus runs correctly and if the module has detected no error.
- The 8 yellow LEDs (1) indicate the signal statuses of the channels E0...E7.

## Diagnosis and displays

Diagnosis functions:

- Error inside the module
- Error on the CS31 system bus

If one of these errors occurs, the red LED (3) lights up.

Using the test button (4) and the LEDs (1), diagnosis information can be achieved directly at the module.

By pressing the test button the first time, the channel **E0** is selected: LED0 flashes. After releasing the test button, the diagnosis information of this channel is displayed with the 8 yellow LEDs for a period of ca. 3 seconds.

The ON status of the LEDs means:

- 0 Error inside the module (Unit error)
- 1 Error on the CS31 system bus (Bus error)
- 2 not used
- 3 not used
- 4 not used
- 5 not used
- 6 not used
- 7 Configuration as an input (Input)

The meaning of the LEDs (2) is also printed on the front panel of the module in English.

With every further pushing and releasing the test button, the described procedure repeats for the other channels.

After calling up the last channel (E7), a lamp test (LED test) is performed when the test button is pushed again. All 8 LEDs must light up.

After releasing the test button, the 8 LEDs show the setting of the DIL switches of the plug-in base for a period of ca. 5 seconds. LED0 shows switch 1 (LEDs 0...7 belong to the switches 1...8).

All error messages are stored in the module. They can be deleted in the following ways:

- by pressing the test button for about 10 seconds or
- with power OFF/ON or
- via the CS31 system bus.

**Diagnosis data, which can be evaluated, are also sent to the basic units and couplers which work as the bus master.**

For further details see the chapter "Diagnosis" in the description of the basic units and couplers.

After finishing the diagnosis procedure, the 8 LEDs again show the signal statuses of the channels. The same is valid for the pauses between the steps of the procedure.

---

## Technical data

### General data of the module

Versions	<b>R 0016</b>
Rated power supply voltage	230 V AC, 50 or 60 Hz
Max. input power	5 VA
Max. power dissipation in the module	6 W
Max. conductor cross section of the terminals (flexible lead with wire end ferrule)	2 cores of 2.5 mm <sup>2</sup> per terminal
Weight	plug-in base ECZ 200 g module ICSI 08 E4 430 g

### Technical data of the inputs

Number of inputs per module	8
Arrangement of the inputs	in 2 groups of 4 channels each, each group has its own reference potential
Electrical isolation	yes, between the groups and from the rest of the module
Electrical isolation from the mains voltage	yes
Signal levels of the inputs:	
Rated voltage	230 V AC, 50 or 60 Hz
Signal 0	0...40 V AC
Signal 1	159...253 V AC
Supply current at 230 V AC	ca. 6.5 mA
Input signal delay	
transition 0 → 1 or 1 → 0	2 to 32 ms configurable, standard setting is 10 ms. After setting via the system bus, the real delay is 10 ms longer than the set value.
Signalling	1 yellow LED per channel

## Mechanical data

Installation methods	on a DIN rail or fastening by screws
Mounting depth including the plug-in base and a flat DIN rail	117 mm
Dimensions of the plug-in base (see the drawing below)	
snapping onto the DIN rail	centrally between top and bottom of the plug-in base
fastening by M4 screws	102 mm x 22 mm
max. outline dimensions of the plug-in base	124 mm x 64 (+12) mm

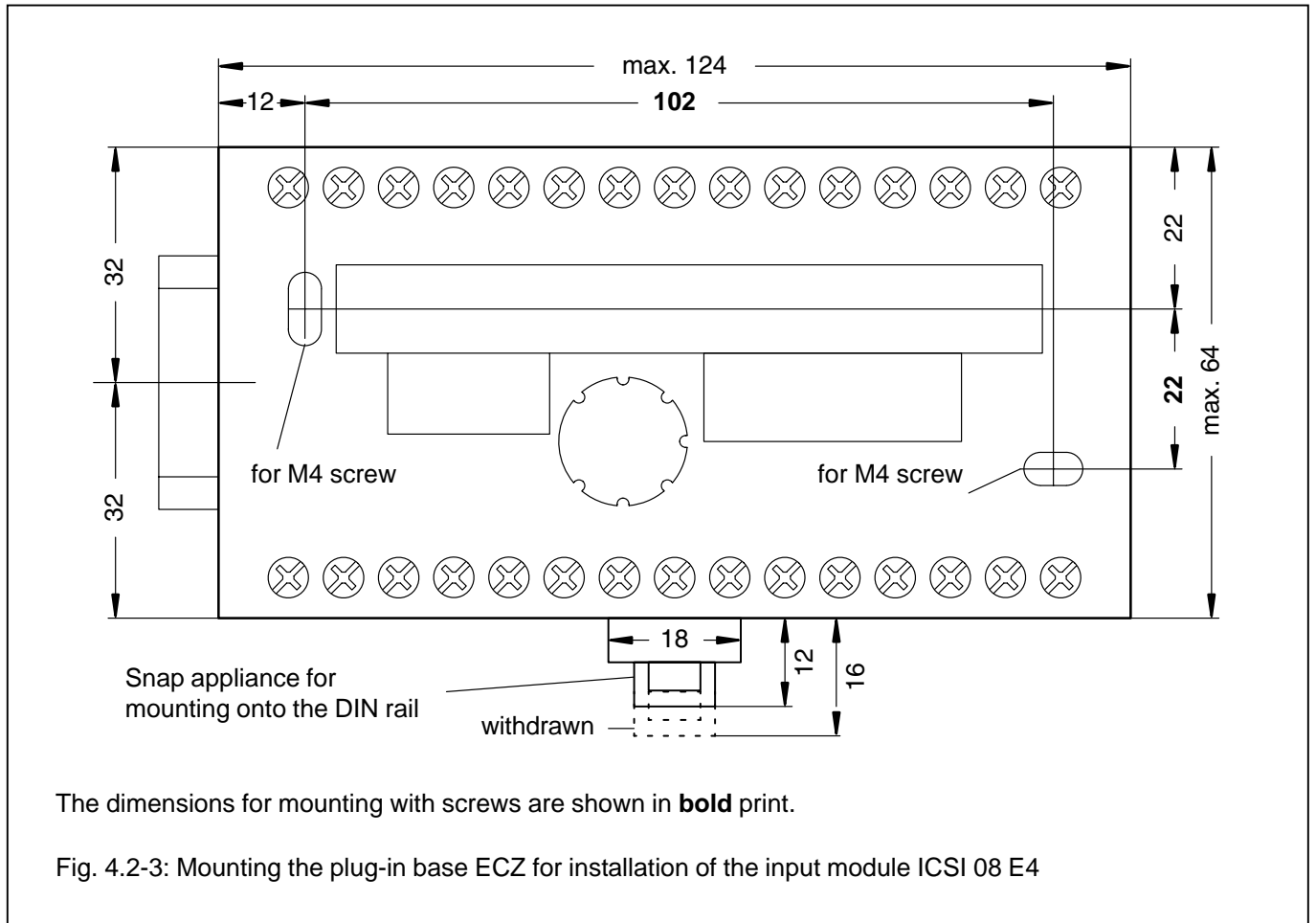

## Ordering data

Order numbers	Plug-in base ECZ	FPR3700001R0001
	Module ICSI 08 E4 230 V AC	FPR3316401R0016



## 4.4 Digital output module ICSO 08 R1, 8 relay outputs 2 A Outputs and CS31 system bus interface electrically isolated

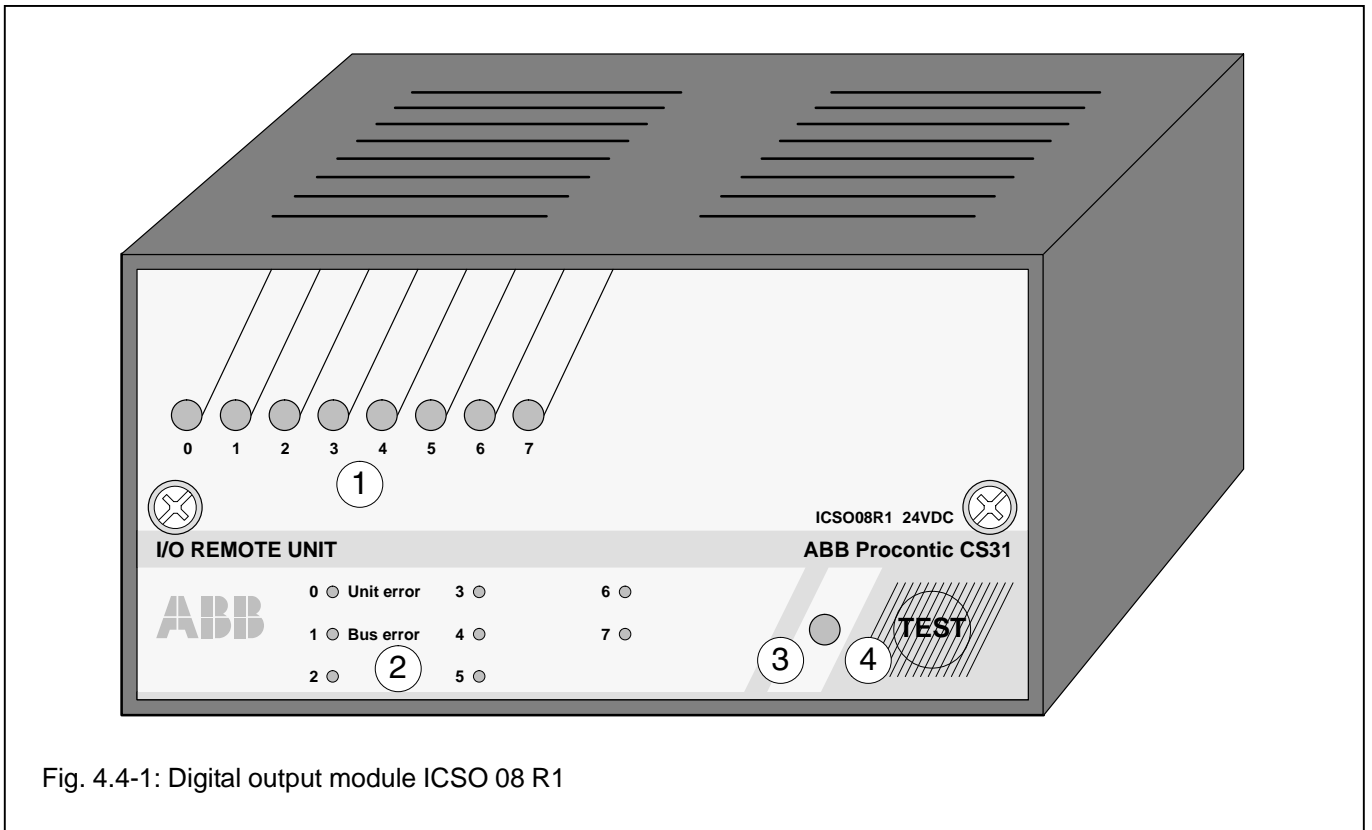

Fig. 4.4-1: Digital output module ICSO 08 R1

### Contents

Intended purpose .....	4.4-1
Display and operating elements on the front panel .....	4.4-1
Electrical connection .....	4.4-1
Addressing .....	4.4-4
I/O configuration .....	4.4-4
Normal operation .....	4.4-4
Diagnosis and displays .....	4.4-4
Technical data .....	4.4-5
Dimensions for installation .....	4.4-6

### Intended purpose

The digital output module ICSO 08 R1 is used as a remote module on the CS31 system bus. It contains 8 relay output channels with the following features:

- The relay outputs
  - are electrically isolated (from each other and from the rest of the module and
  - can be loaded with 2 A.

The module is available for supply voltages of 24 V DC and 230 V AC. For electrical connection, it has to be mounted on a plug-in base ECZ.

The CS31 system bus interface is electrically isolated from the rest of the module.

The module offers a number of diagnosis functions (see chapter "Diagnosis and displays").

### Display and operating elements on the front panel

- ① 8 yellow LEDs to indicate the signal status of the outputs or for displaying error and diagnosis data
- ② List of diagnosis information concerning the LEDs when they are used for diagnosis display
- ③ Red LED for error message
- ④ Test button

### Electrical connection

The module has to be mounted on the plug-in base ECZ and then fastened with two screws. The plug-in base has a mechanical coding which prevents that a module can be plugged-in with another supply voltage than set on the ECZ. Before mounting the input module, the mechanical coding has to be set to the correct supply voltage.

The following three figures show the electrical connection of the output module.

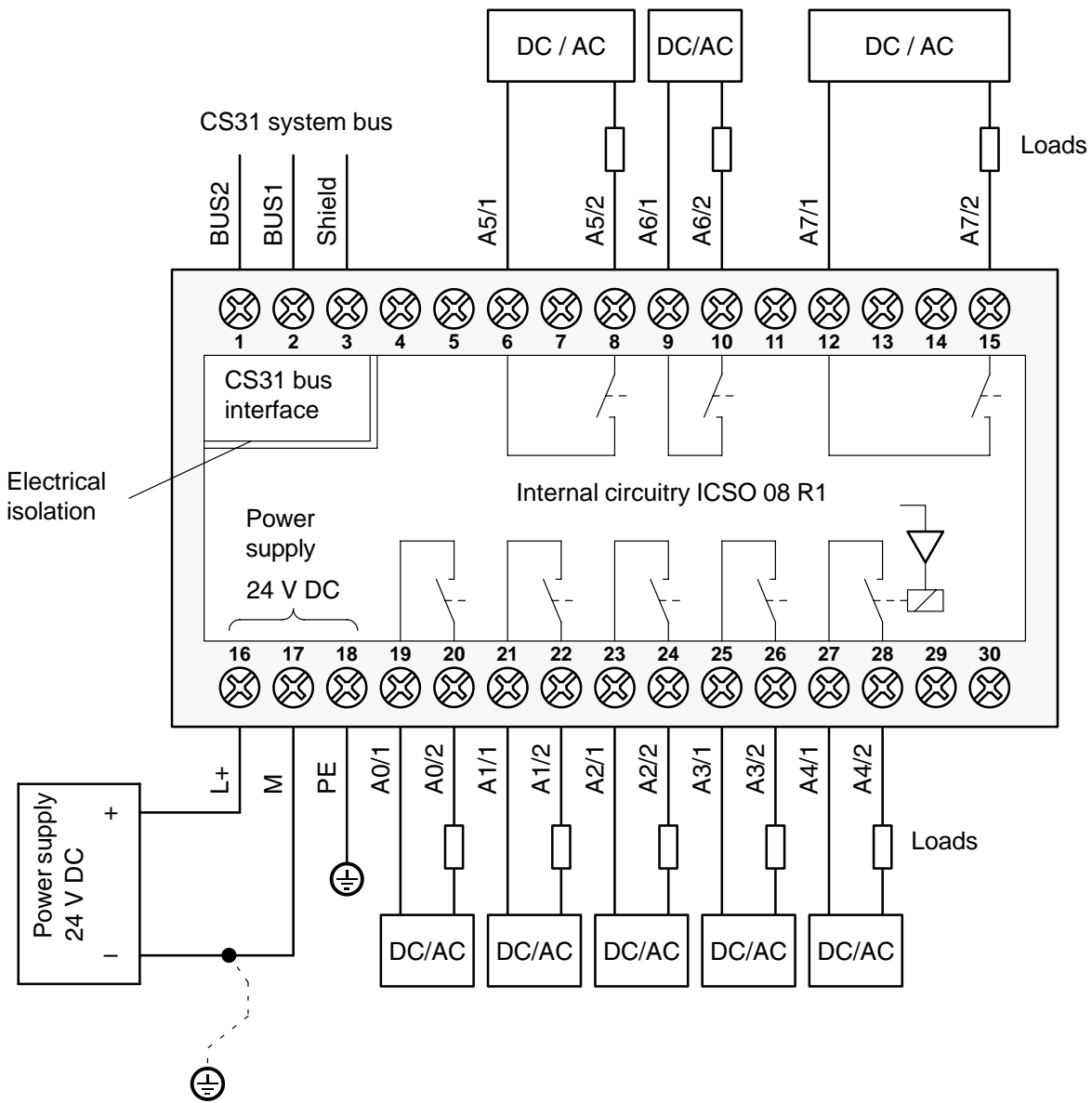

Important: The supply voltage must be included in the earthing concept of the control system (e.g. earthing of the minus pole).

Addressing and I/O configuration are set with this DIL switch.

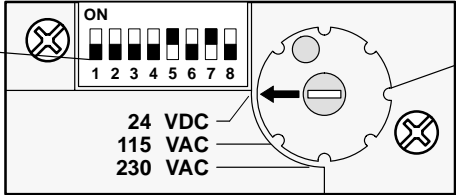

The supply voltage is set with this mechanical coding.

Fig. 4.4-2: Electrical connection of the digital output module ICSO 08 R1, supply voltage 24 V DC

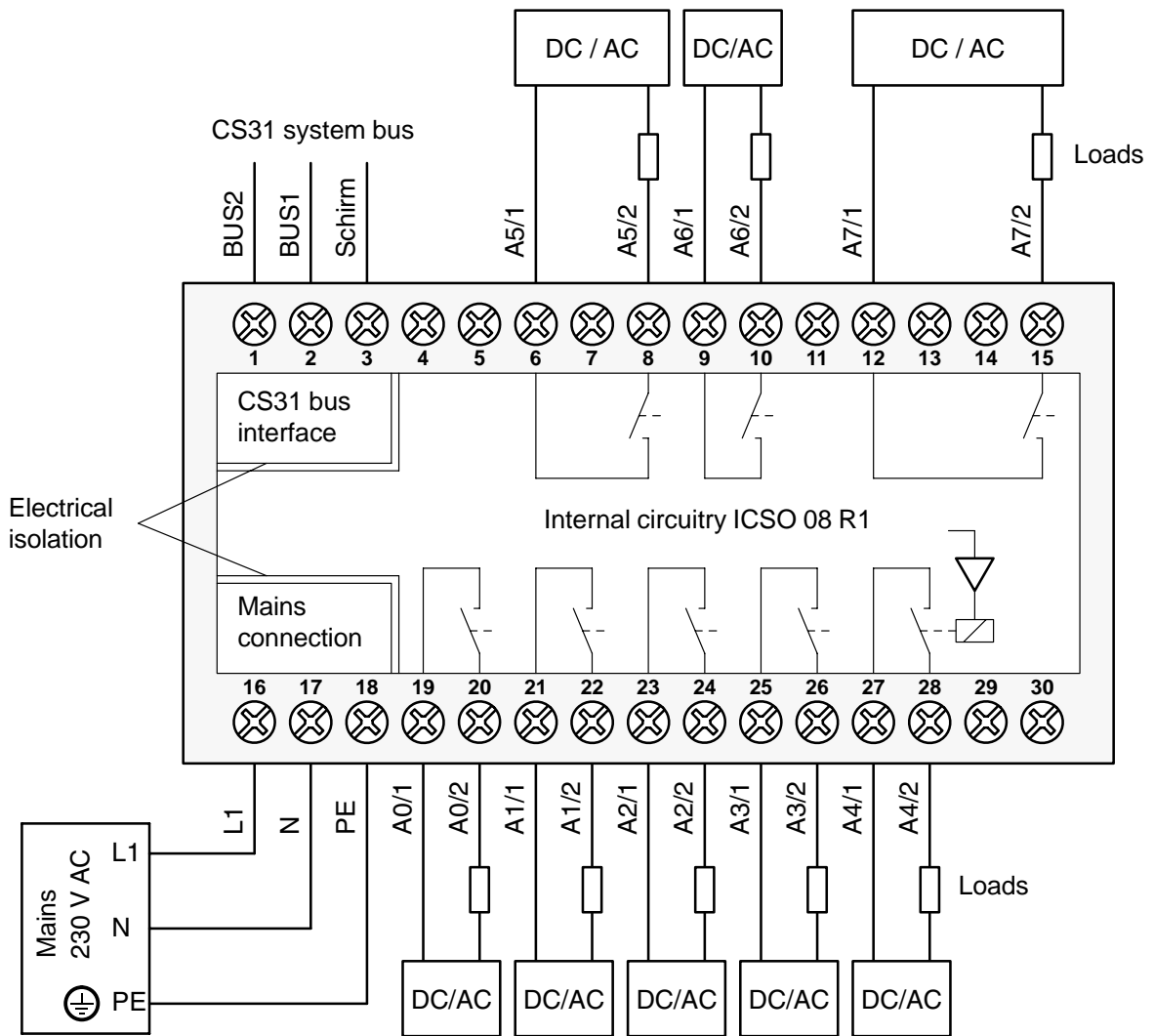

Addressing and I/O configuration are set with this DIL switch.

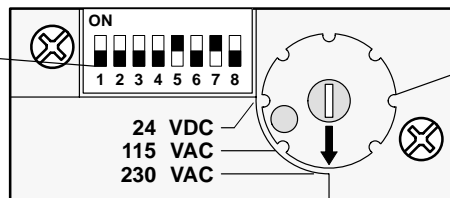

The supply voltage is set with this mechanical coding.

Fig. 4.4-3: Electrical connection of the digital output module ICSO 08 R1, supply voltage 230 V AC

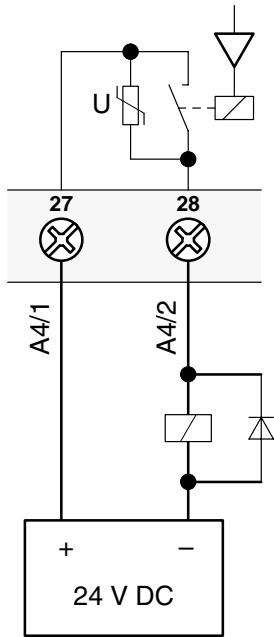

In order to suppress switching sparks when switching inductive AC loads, the relay contacts are equipped with varistors.

If, however, **inductive DC loads** are switched, **one free-wheeling diode must be mounted in parallel to each of the loads** for demagnetization.

Fig. 4.4-4: Electrical connection of inductive DC loads

## Addressing

An address must be set for each module to enable the basic unit to correctly access the outputs.

The address setting is accomplished with the DIL switch on the plug-in base ECZ. When using the basic units 07 KR 91 and 07 KT 9x as bus masters, the following address assignments are valid:

Basic unit	07 KR 91 / 07 KT 9x	
DIL switch No. 8 on the ECZ	OFF (recommended)	ON
Channel		
A0	A xx,00	A xx,08
A1	A xx,01	A xx,09
A2	A xx,02	A xx,10
A3	A xx,03	A xx,11
A4	A xx,04	A xx,12
A5	A xx,05	A xx,13
A6	A xx,06	A xx,14
A7	A xx,07	A xx,15
xx: Group number of the address, set on the DIL switch of the plug-in base with the switches 2...7. Recommended addresses with 07 KR 91 / 07 KT 9x as bus masters: 08, 10, 12...60 (even-numbered addresses)		

**A detailed description about "Addressing" can be found in the chapter "Addressing" of the basic units and couplers.**

The module uses 8 outputs on the CS31 system bus.

## I/O configuration

An I/O configuration is not necessary.

## Normal operation

- After power ON the module initializes automatically. During this period the red LED (3) flashes.
- After initialization the red LED (3) goes out, if the bus runs correctly and if the module has detected no error.
- The 8 yellow LEDs (1) indicate the signal statuses of the channels A0...A7.

## Diagnosis and displays

Diagnosis functions:

- Error inside the module
- Error on the CS31 system bus

If one of these errors occurs, the red LED (3) lights up.

Using the test button (4) and the LEDs (1), diagnosis information can be achieved directly at the module.



By pressing the test button the first time, the channel **A0** is selected: LED0 flashes. After releasing the test button, the diagnosis information of this channel is displayed with the 8 yellow LEDs for a period of ca. 3 seconds.

The ON status of the LEDs means:

- 0 Error inside the module (Unit error)
- 1 Error on the CS31 system bus (Bus error)
- 2...7 not used

The meaning of the LEDs (2) is also printed on the front panel of the module in English.

With every further pushing and releasing the test button, the described procedure repeats for the other channels.

After calling up the last channel (A7), a lamp test (LED test) is performed when the test button is pushed again. All 8 LEDs must light up.

After releasing the test button, the 8 LEDs show the setting of the DIL switches of the plug-in base for a period of ca. 5 seconds. LED0 shows switch 1 (LEDs 0...7 belong to the switches 1...8).

All error messages are stored in the module. They can be deleted in the following ways:

- by pressing the test button for about 10 seconds or
- with power OFF/ON or
- via the CS31 system bus.

**Diagnosis data, which can be evaluated, are also sent to the basic units and couplers which work as the bus master.**

For further details see the chapter "Diagnosis" in the description of the basic units and couplers.

After finishing the diagnosis procedure, the 8 LEDs again show the signal statuses of the channels. The same is valid for the pauses between the steps of the procedure.

## Technical data

### General data of the module

Versions	R 1022	R0026
Rated supply voltage	24 V DC	230 V AC, 50 or 60 Hz
Max. current consumption without output loads	0.2 A	
Max. power consumption without output loads		6 VA
Max. power dissipation in the module	5 W	5 W
Max. conductor cross section of the terminals (flexible lead with wire end ferrule)	2 cores of 2.5 mm <sup>2</sup> per terminal	
Weight	Plug-in base ECZ Module ICSO 08 R1	200 g 430 g

### Technical data of the outputs

Number of outputs per module	8 relay outputs (1 make contact each)
Process supply voltage / contact voltage	max. 250 V AC
Data of the relay contacts	
Switching current	max. 2 A
Total current of the 8 outputs	max. 16 A
Switching power AC	max. 500 VA
Switching power DC	max. 60 W
Minimum switching power	0.1 mA / 0.1 V DC
Contact life cycle	
mechanical	> 3 x 10 <sup>7</sup> cycles
230 V AC, 2 A resistive load	> 1 x 10 <sup>5</sup> cycles
Protection for relay contacts when switching inductive loads	
with AC	built-in varistor
with DC	a free-wheeling diode must be circuited in parallel to the load
Signalling	1 yellow LED per channel

## Mechanical data

Installation methods	on a DIN rail or fastening by screws
Mounting depth including the plug-in base and a flat DIN rail	117 mm
Dimensions of the plug-in base (see the drawing below)	
snapping onto the DIN rail	centrally between top and bottom of the plug-in base
fastening by M4 screws	102 mm x 22 mm
max. outline dimensions of the plug-in base	124 mm x 64 (+12) mm

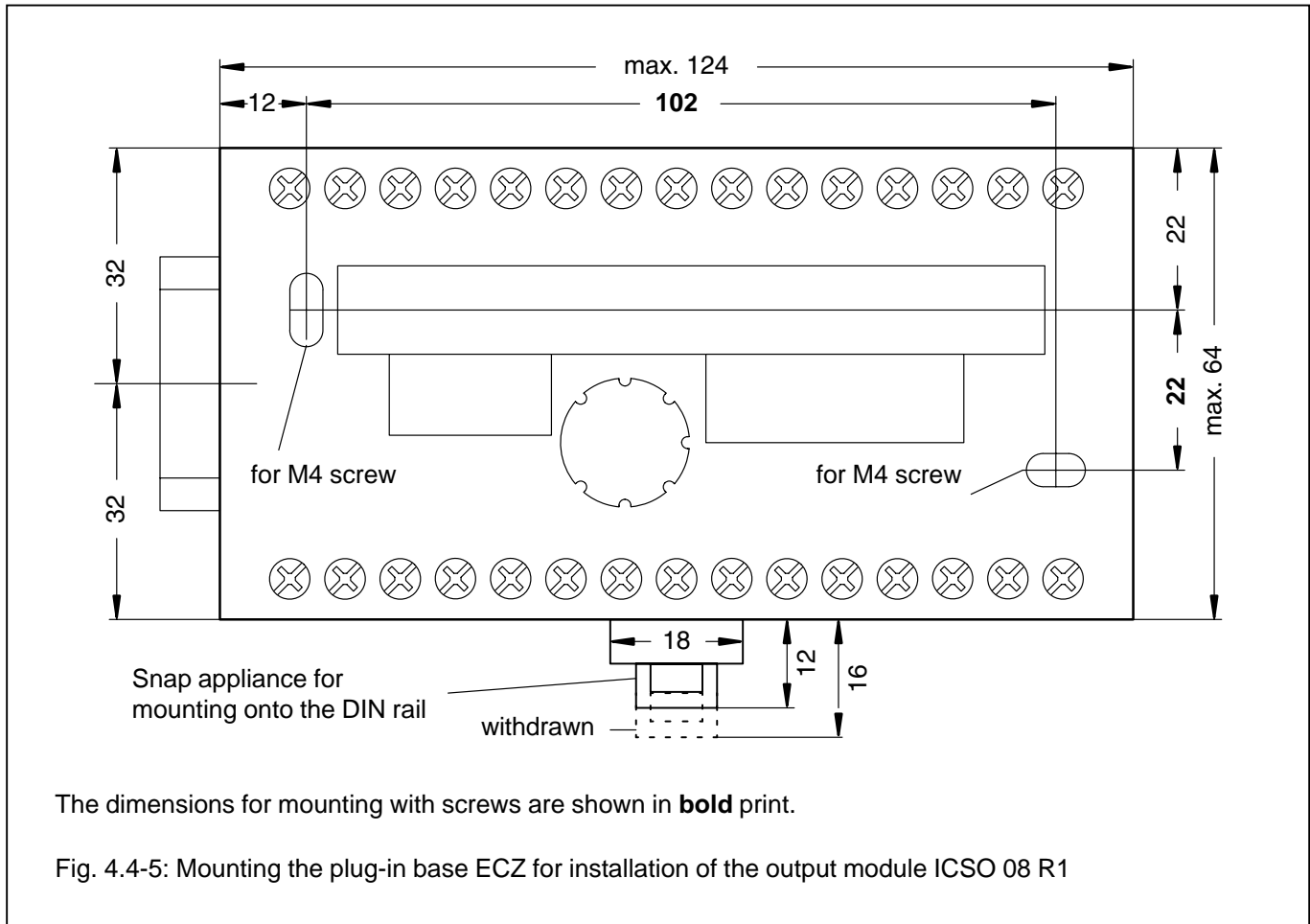

## Ordering data

Order numbers	Plug-in base ECZ		FPR3700001R0001
	Module ICSO 08 R1	24 V DC	FPR3312101R1022
	Module ICSO 08 R1	230 V AC	FPR3312101R0026

## 4.5 Digital output module ICSO 08 Y1, 8 channels 24 V DC, 2 A Outputs and CS31 system bus interface electrically isolated

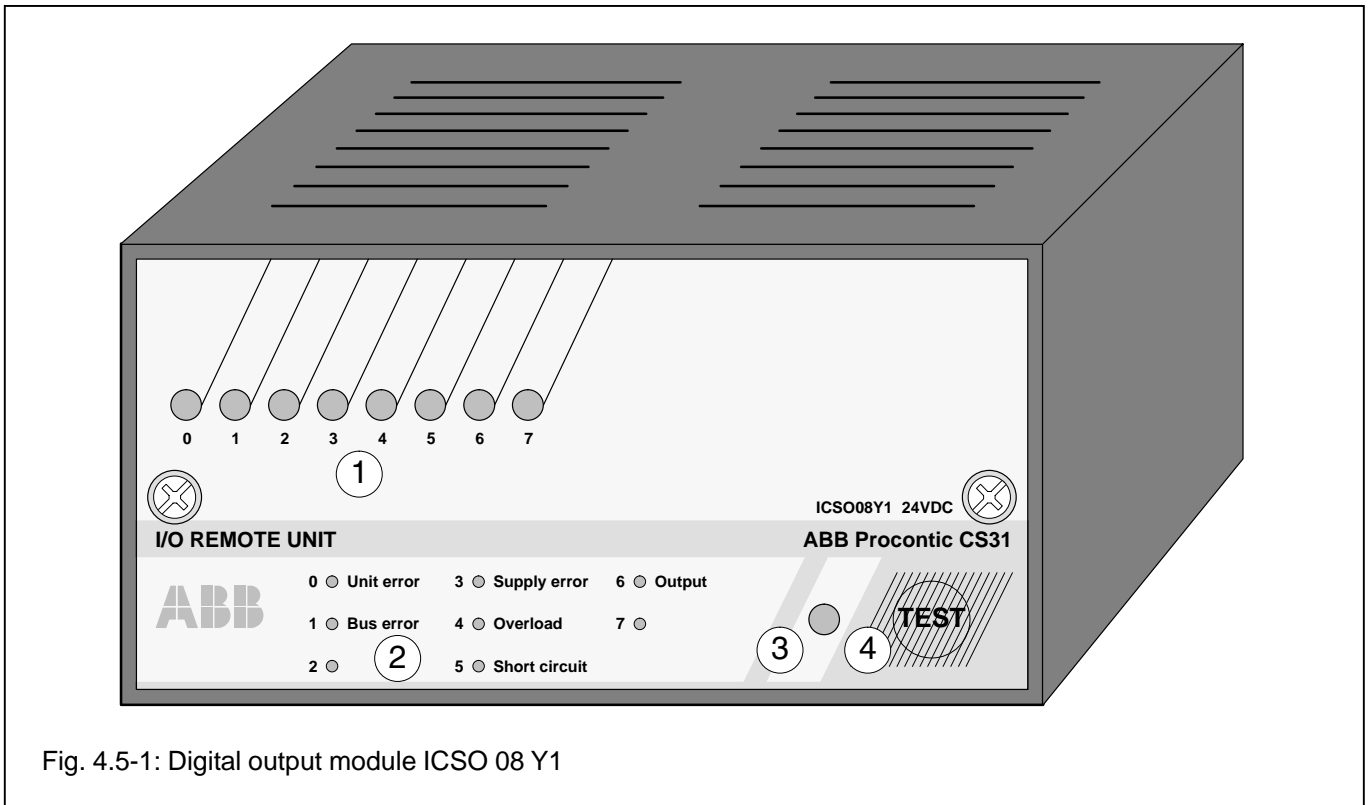

Fig. 4.5-1: Digital output module ICSO 08 Y1

### Contents

Intended purpose .....	4.5-1
Display and operating elements on the front panel .....	4.5-1
Electrical connection .....	4.5-1
Addressing .....	4.5-4
I/O configuration .....	4.5-4
Normal operation .....	4.5-4
Diagnosis and displays .....	4.5-4
Technical data .....	4.5-5
Dimensions for installation .....	4.5-6

### Intended purpose

The digital output module ICSO 08 Y1 is used as a remote module on the CS31 system bus. It contains 8 output channels with the following features:

- The outputs
    - are electrically isolated
    - have a rated voltage of 24 V DC
    - work with transistors
    - are overload and short-circuit proof and
    - can be loaded with 2 A.
- Note: The minimum load must be  $\geq 50$  mA. If the load is lower than 50 mA, the safe OFF state cannot be guaranteed because of the output leakage current. (Recommendation: Use module ICSC 08 L1, if the loads are lower than 50 mA.)

The module is available for supply voltages of 24 V DC and 230 V AC.

For electrical connection, it has to be mounted on a plug-in base ECZ.

The CS31 system bus interface is electrically isolated from the rest of the module.

The module offers a number of diagnosis functions (see chapter "Diagnosis and displays").

### Display and operating elements on the front panel

- ① 8 yellow LEDs to indicate the signal status of the outputs or for displaying error and diagnosis data
- ② List of diagnosis information concerning the LEDs when they are used for diagnosis display
- ③ Red LED for error message
- ④ Test button

### Electrical connection

The module has to be mounted on the plug-in base ECZ and then fastened with two screws. The plug-in base has a mechanical coding which prevents that a module can be plugged-in with another supply voltage than set on the ECZ. Before mounting the input module, the mechanical coding has to be set to the correct supply voltage.

The following two figures show the electrical connection of the output module.

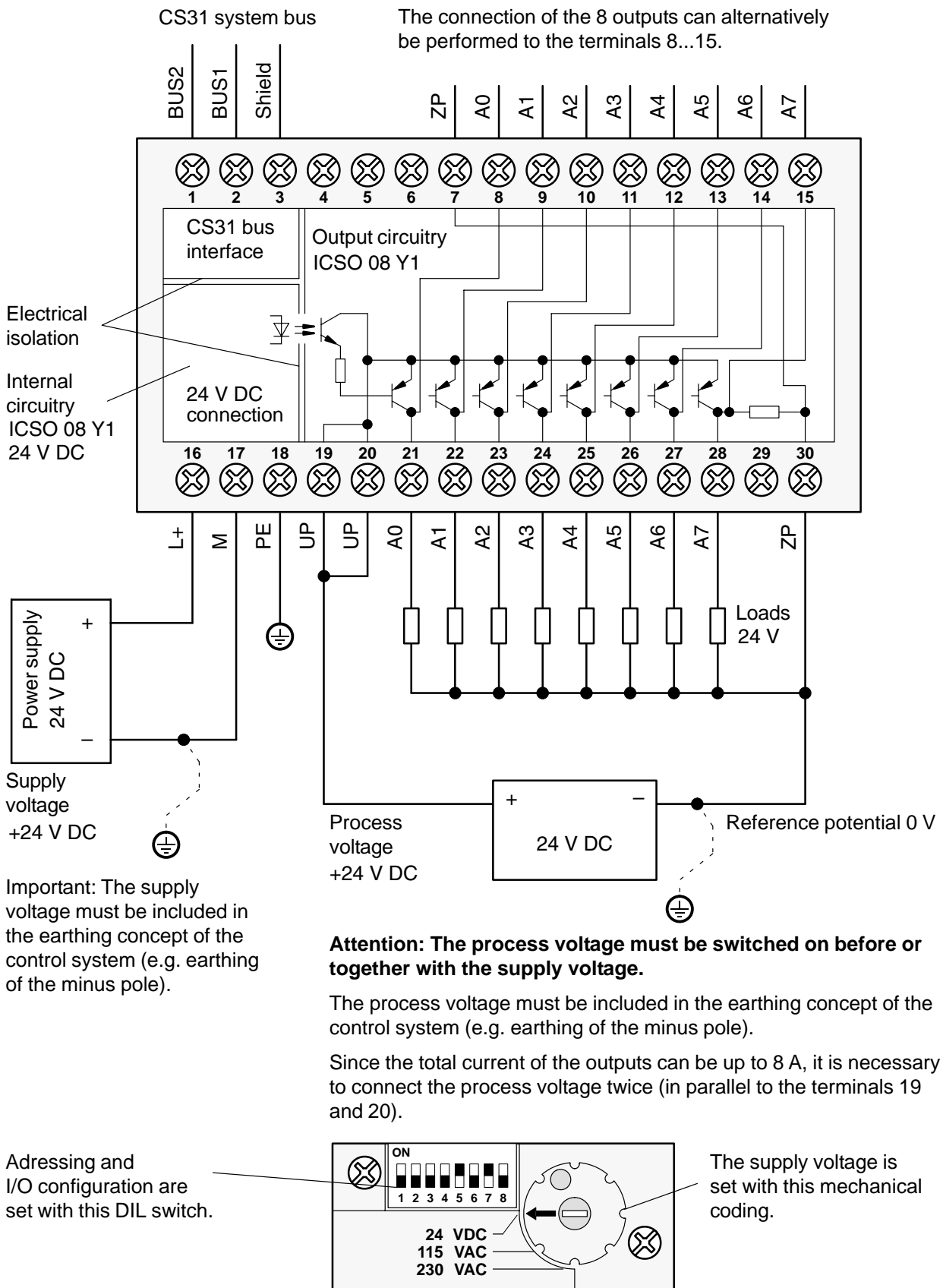
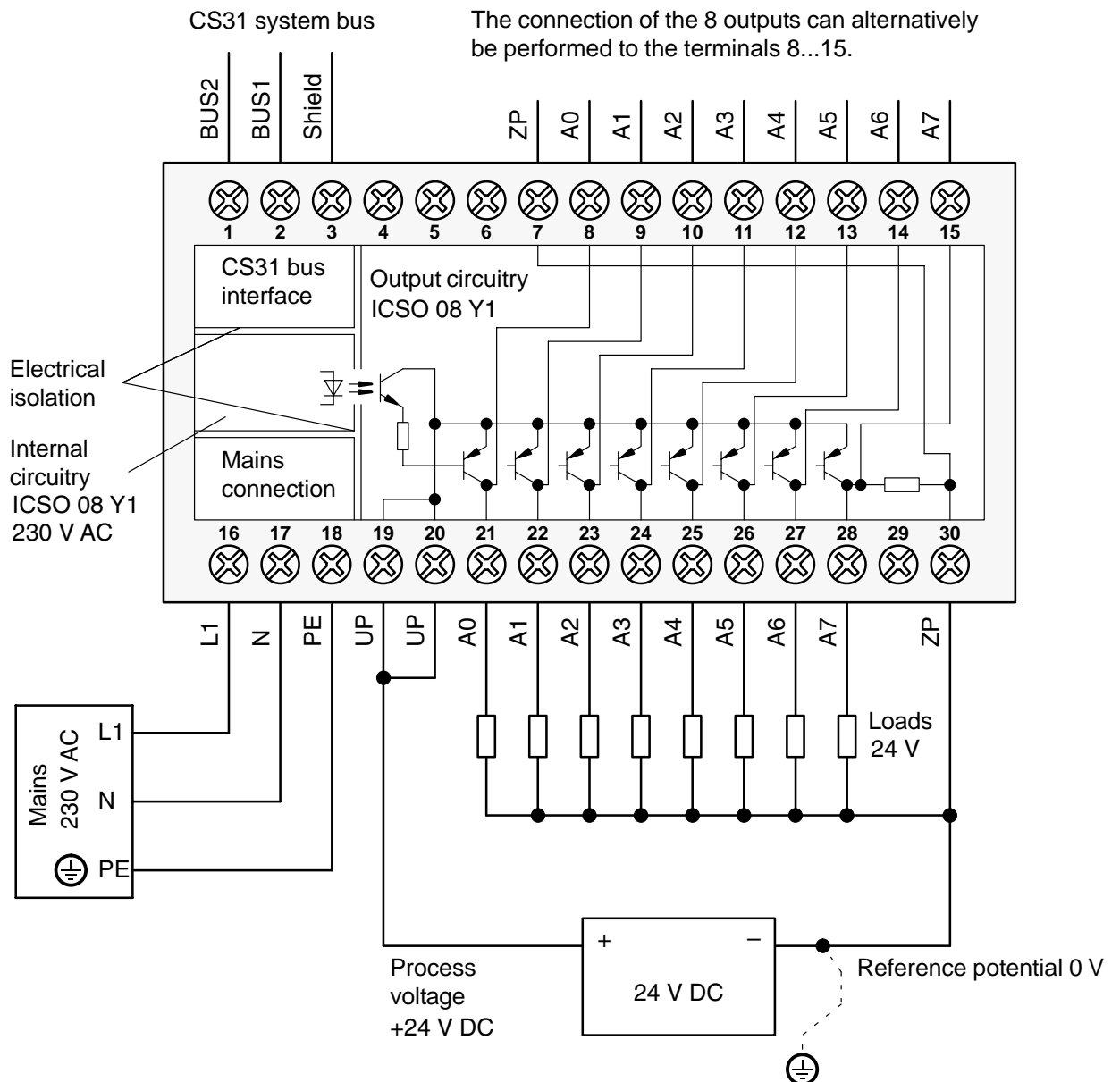

Fig. 4.5-2: Electrical connection of the digital output module ICSO 08 Y1, supply voltage 24 V DC



**Attention: The process voltage must be switched on before the supply voltage of 230 V AC.**

The process voltage must be included in the earthing concept of the control system (e.g. earthing of the minus pole).

Since the total current of the outputs can be up to 8 A, it is necessary to connect the process voltage twice (in parallel to the terminals 19 and 20).

Addressing and I/O configuration are set with this DIL switch.

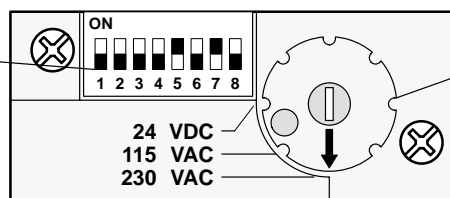

The supply voltage is set with this mechanical coding.

Fig. 4.5-3: Electrical connection of the digital output module ICSO 08 Y1, supply voltage 230 V AC

## Addressing

An address must be set for each module to enable the basic unit to correctly access the outputs.

**A detailed description about "Addressing" can be found in the chapter "Addressing" of the basic units and couplers.**

The address setting is accomplished with the DIL switch on the plug-in base ECZ. When using the basic units 07 KR 91 and 07 KT 9x as bus masters, the following address assignments are valid:

Basic unit		07 KR 91 / 07 KT 9x	
DIL switch No. 8 on the ECZ	OFF (recommended)	ON	
Channel			
A0	A xx,00	A xx,08	
A1	A xx,01	A xx,09	
A2	A xx,02	A xx,10	
A3	A xx,03	A xx,11	
A4	A xx,04	A xx,12	
A5	A xx,05	A xx,13	
A6	A xx,06	A xx,14	
A7	A xx,07	A xx,15	

xx: Group number of the address, set on the DIL switch of the plug-in base with the switches 2...7. Recommended addresses with 07 KR 91 / 07 KT 9x as bus masters: 08, 10, 12...60 (even-numbered addresses)

The module uses 8 outputs on the CS31 system bus.

## I/O configuration

An I/O configuration is not necessary.

## Normal operation

- After power ON the module initializes automatically. During this period the red LED (3) flashes.
- After initialization the red LED (3) goes out, if the bus runs correctly and if the module has detected no error.
- The 8 yellow LEDs (1) indicate the signal statuses of the channels A0...A7.

## Diagnosis and displays

Diagnosis functions:

- Error inside the module
- Error on the CS31 system bus
- Process voltage is OFF
- Overload
- Short-circuit

If one of these errors occurs, the red LED (3) lights up.

Using the test button (4) and the LEDs (1), diagnosis information can be achieved directly at the module.

By pressing the test button the first time, the channel **A0** is selected: LED0 flashes. After releasing the test button, the diagnosis information of this channel is displayed with the 8 yellow LEDs for a period of ca. 3 seconds.

The ON status of the LEDs means:

- 0 Error inside the module (Unit error)
- 1 Error on the CS31 system bus (Bus error)
- 2 not used
- 3 Process voltage is OFF (Supply error)
- 4 Overload
- 5 Short-circuit
- 6 Configuration as an output (Output)

The meaning of the LEDs (2) is also printed on the front panel of the module in English.

With every further pushing and releasing the test button, the described procedure repeats for the other channels.

After calling up the last channel (A7), a lamp test (LED test) is performed when the test button is pushed again. All the 8 LEDs must light up.

After releasing the test button, the 8 LEDs show the setting of the DIL switches of the plug-in base for a period of ca. 5 seconds. LED0 shows switch 1 (LEDs 0...7 belong to the switches 1...8).

All error messages are stored in the module. They can be deleted in the following ways:

- by pressing the test button for about 10 seconds or
- with power OFF/ON or
- via the CS31 system bus.

**Diagnosis data, which can be evaluated, are also sent to the basic units and couplers which work as the bus master.**

For further details see the chapter "Diagnosis" in the description of the basic units and couplers.

After finishing the diagnosis procedure, the 8 LEDs again show the signal statuses of the channels. The same is valid for the pauses between the steps of the procedure.

## Technical data

### General data of the module

Versions	<b>R 1022</b>	<b>R0026</b>
Rated supply voltage	24 V DC	230 V AC, 50 or 60 Hz
Max. current consumption without output loads	0.2 A	
Max. power consumption without output loads		6 VA
Max. power dissipation in the module	6 W	8 W
Max. conductor cross section of the terminals (flexible lead with wire end ferrule)	2 cores of 2.5 mm <sup>2</sup> per terminal	
Weight	Plug-in base ECZ Module ICSO 08 Y1	200 g 430 g

### Technical data of the outputs

Number of outputs per module	max. 8 (short-circuit and overload proof, electrically isolated)
Process supply voltage UP	24 V DC
Signal level of the outputs with signal 1	UP, (max. internal voltage drop 0.5 V)
Leakage current with signal 0	< 4 mA
Loadability of the outputs	
Rated current	2 A
Lamp load	max. 15 W
Total current of the 8 outputs	max. 8 A
Switching frequency with inductive load	max. 0.1 Hz
Overload indication	yes
Short-circuit switch-off / short-circuit indication	yes
Limitation of inductive switch-off voltage	by suppressor diode
Signalling	1 yellow LED per channel

## Mechanical data

Installation methods	on a DIN rail or fastening by screws
Mounting depth including the plug-in base and a flat DIN rail	117 mm
Dimensions of the plug-in base (see the drawing below)	
snapping onto the DIN rail	centrally between top and bottom of the plug-in base
fastening by M4 screws	102 mm x 22 mm
max. outline dimensions of the plug-in base	124 mm x 64 (+12) mm

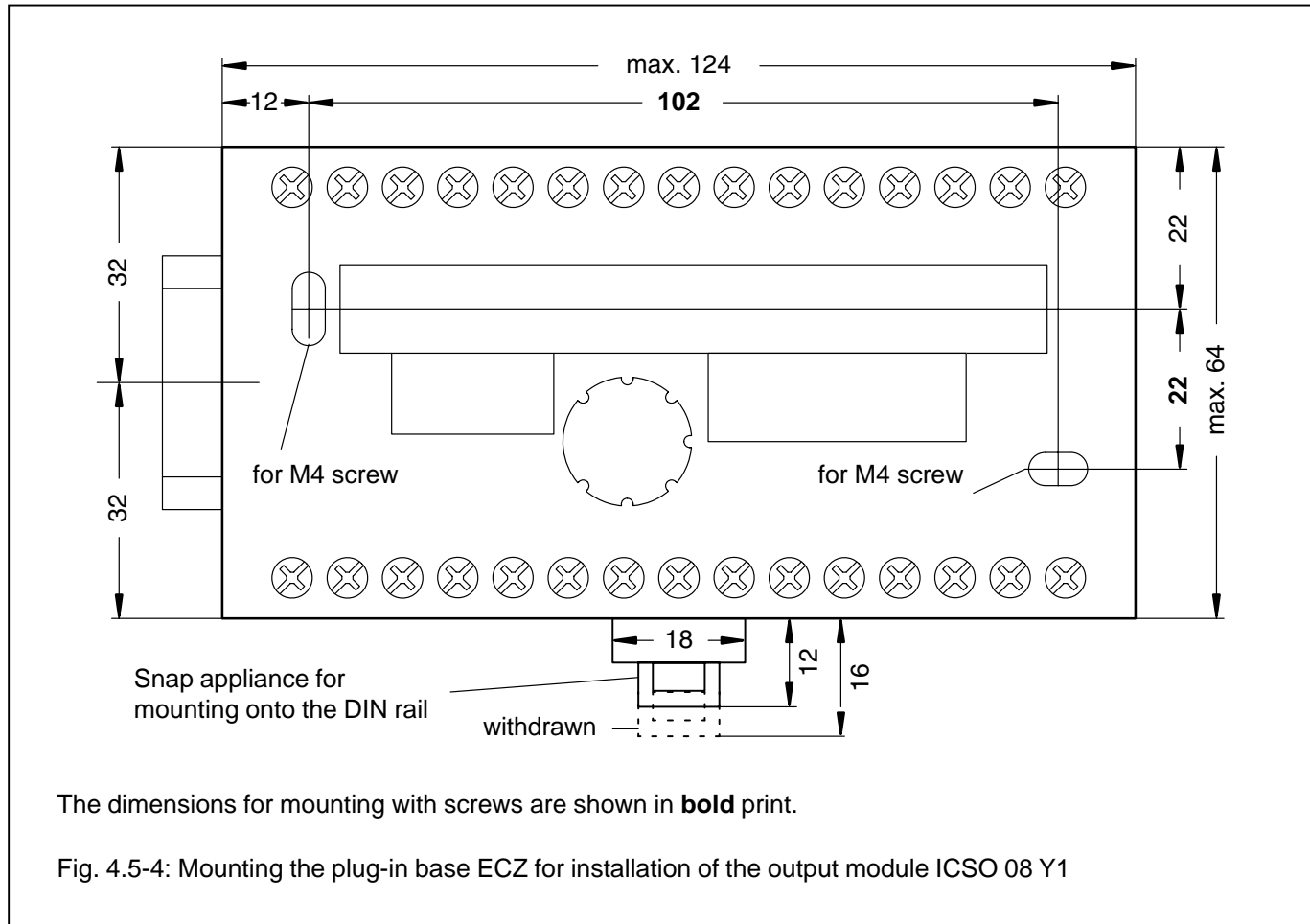

## Ordering data

Order numbers	Plug-in base ECZ		FPR3700001R0001
	Module ICSO 08 Y1	24 V DC	FPR3311101R1022
	Module ICSO 08 Y1	230 V AC	FPR3311101R0026



## 4.7 Digital Input/Output Module 07 DC 91

16 digital inputs, 8 digital outputs, 8 configurable inputs/outputs, 24 V DC, CS31 system bus

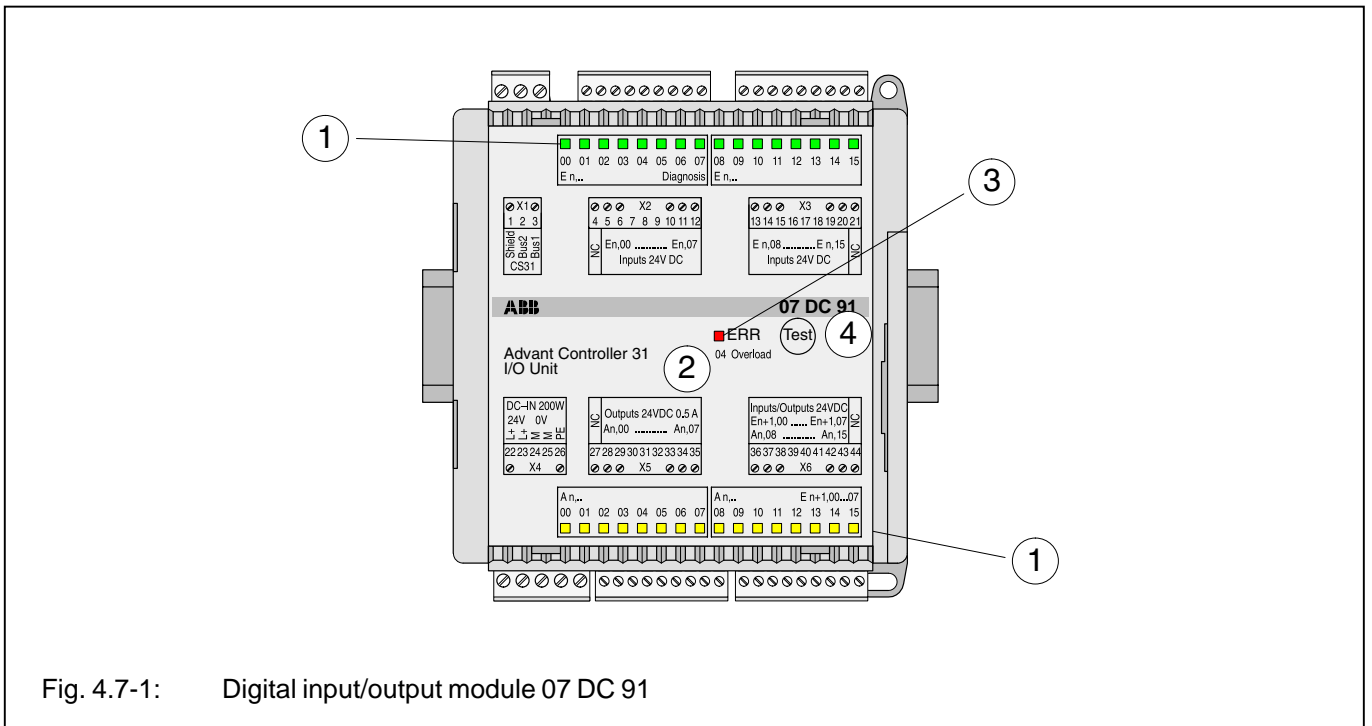

Fig. 4.7-1: Digital input/output module 07 DC 91

### Contents

Intended purpose .....	4.7-1
Display and operating elements on the front panel .....	4.7-1
Electrical connection .....	4.7-1
Addressing .....	4.7-3
Input/output configuration .....	4.7-4
Normal operation .....	4.7-4
Diagnosis and display .....	4.7-4
Technical data .....	4.7-5
Dimensions for installation .....	4.7-8

The technical data are identical with the normal inputs and outputs.

The operating voltage of the module is 24 V DC.

The system bus connection is electrically isolated from the rest of the unit.

The module offers a number of diagnosis functions (see chapter "Diagnosis and displays").

### Intended purpose

The digital input/output module 07 DC 91 is used as a remote module on the CS31 system bus. It has 32 channels with the following features:

- 16 inputs, 24 V DC, in two groups.
- 8 outputs, 24 V DC, in one group.  
The outputs
  - work with transistors,
  - have a rated load capacity of 0.5 A and
  - are protected against overload and short circuits.
- 8 inputs/outputs, each of which can be addressed
  - as input,
  - as output or
  - as re-readable output (combined input/output)

### Displays and operating elements on the front panel

- ① 16 green LEDs to indicate the signal status at the inputs,  
16 yellow LEDs to indicate the signal status at the outputs or at the configurable inputs/outputs
- ② List of diagnosis information related to the LEDs, when used for diagnosis display
- ③ Red LED for error message
- ④ Test button

### Electrical connection

The module is mounted on a DIN rail (15 mm high) or with 4 screws. The following illustration shows the electrical connection of the input/output module.

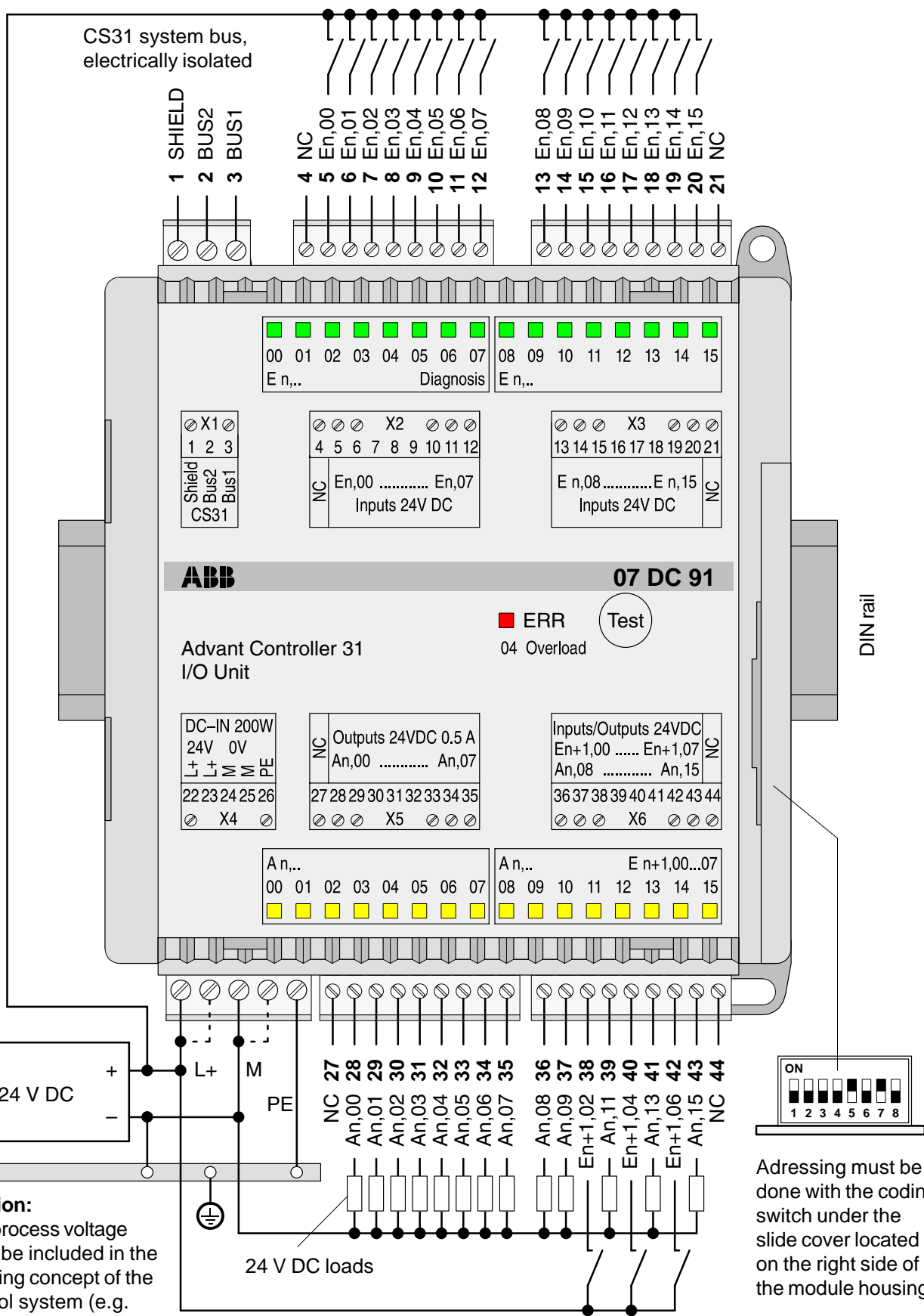

**Caution:**  
The process voltage must be included in the earthing concept of the control system (e.g. earthing of the minus terminal)

Addressing must be done with the coding switch under the slide cover located on the right side of the module housing.

Fig. 4.7-2: Electrical connection of the digital input/output module 07 DC 91. The example shows 19 channels used as inputs and 13 channels used as outputs.

## Addressing

An address must be set for each module to enable the central unit to correctly access the inputs and outputs.

**A detailed description about "Addressing" can be found in the chapter "Addressing" for the central processing unit and coupler.**

The address must be set at the DIL switch, located under the slide cover on the right side of the module.

When using the central units 07 KR 91, 07 KT 9x as bus master, the following **operating modes** (address allocations) apply, depending on the position of the address DIL switch No.1:

Central units 07 KR 91 / 07 KT 9x			
When the address DIL switch <b>No. 1</b> is set to <b>ON</b> , it means that 16 inputs and 16 outputs are <b>permanently</b> allocated. In this case all configurable channels are outputs.			
Address DIL switch <b>No. 8</b> is not used.			
Terminal/Input		Terminal/Output	
5	E n,00	28	A n,00
6	E n,01	29	A n,01
7	E n,02	30	A n,02
8	E n,03	31	A n,03
9	E n,04	32	A n,04
10	E n,05	33	A n,05
11	E n,06	34	A n,06
12	E n,07	35	A n,07
13	E n,08	36	A n,08
14	E n,09	37	A n,09
15	E n,10	38	A n,10
16	E n,11	39	A n,11
17	E n,12	40	A n,12
18	E n,13	41	A n,13
19	E n,14	42	A n,14
20	E n,15	43	A n,15

n: The group number can be set at address DIL switch with switches 2...7.  
Recommended module addresses for 07 KR 91 / 07 KT 9x as bus master are 08, 10, 12...60 (even-numbered addresses)

With this setting, the module uses **only one** group number on the CS31 system bus. In this case 16 inputs and outputs are available.

Fig. 4.7-3: Addresses of the channels when DIL switch No. 1 is set to ON

Central units 07 KR 91 / 07 KT 9x				
When the address DIL switch <b>No. 1</b> is in the <b>OFF</b> position (factory setting), it means that 16 inputs and 8 outputs are <b>permanently</b> set. The 8 configurable channels can be addressed individually as inputs or outputs.				
Address DIL switch <b>No. 8</b> is not used.				
Terminal/Input		Terminal/Output		Input
5	E n,00	28	A n,00	
6	E n,01	29	A n,01	
7	E n,02	30	A n,02	
8	E n,03	31	A n,03	
9	E n,04	32	A n,04	
10	E n,05	33	A n,05	
11	E n,06	34	A n,06	
12	E n,07	35	A n,07	
13	E n,08	36	A n,08	E n+1,00
14	E n,09	37	A n,09	E n+1,01
15	E n,10	38	A n,10	E n+1,02
16	E n,11	39	A n,11	E n+1,03
17	E n,12	40	A n,12	E n+1,04
18	E n,13	41	A n,13	E n+1,05
19	E n,14	42	A n,14	E n+1,06
20	E n,15	43	A n,15	E n+1,07

n: The group number can be set at address DIL switch with switches 2...7.  
Recommended module addresses for 07 KR 91 / 07 KT 9x as bus master: 08, 10, 12...60 (even-numbered addresses)

With this setting, the module uses **two** group numbers on the CS31 system bus occupying 24 binary input channels and 16 binary output channels. 16 inputs, 8 outputs and 8 configurable inputs/outputs are available. An +1,00...15 and En1,08...15 are not used. They can be used for other modules if needed.

Fig. 4.7-4: Addresses of channels when DIL switch No. 1 is set to OFF

**Note:**  
Module 07 DC 91 reads the setting of the address switch **only** during the initialization, after switching on the power supply, meaning that changes of the setting during operation remain ineffective until the next initialization process.

## Input/output configuration

Module 07 DC 91 does not store any configuration data. The 8 configurable channels are defined as inputs or outputs by the user program, e.g. by reading or writing data in the user program. Every configurable input/output channel can be used as input or output (or re-readable output). When used as input, the channel must not be assigned a 1 signal (see Fig. 4.7-3 and 4.7-4 for setting of the address DIL switch and address assignment).

## Normal operation

- The module initializes automatically after power is switched on. During this time all LEDs are switched on.
- If the CS31 system bus does not run, the LED ③ flashes
- LED ③ goes out again after the bus operation runs correctly and the module does not detect an error.
- The 16 green and the 16 yellow LEDs ① indicate the signal status of the 32 channels.

## Diagnosis and display

In case of an overload or a short-circuit, the output switches off and then performs re-starting attempts. An acknowledgement of the output is therefore not necessary. However, the error message is displayed by the LED.

Diagnosis functions:

- Short-circuit / overload of outputs ( $I > 0.7 \text{ A}$ )
- Reporting of a short-circuit or overload condition to the central unit
- Storing and making this information available when recalled (kind of error and error location)
- Error inside of module
- Error on CS31 system bus

If one of these errors occur, the red LED ③ lights up. **The error is transmitted to the central unit or the coupler.** For additional information see instructions supplied there under "Diagnosis".

Using test button ④ and the LED displays ① a diagnosis interrogation can be performed directly at the unit.

Pressing the test button for the first time, En,00 is selected: the status LED of the selected input flashes, all other status displays are switched off during this test. After releasing the test button, the diagnosis information for this channel is displayed for about 3 seconds by the green LEDs 00 to 07.

Explanation of LEDs:

00	not used
01	not used
02	not used
03	not used
04	Overload or short circuit, only for outputs
05	not used
06	not used
07	not used

The explanation for the LEDs ② is also printed on the front panel in English.

With every successive pressing and releasing of the test button, the process is repeated for the other input and output channels ( I/O channels).

After calling up the last channel and pressing the test button once again, an LED test is performed. All LEDs must light up. Then the setting of the address switch is displayed for about 3 seconds by LEDs 00 to 07 which the 07 DC 91 module has set during initialization. In this case LED 0 shows the setting of switch 1 (LEDs 0...7 are assigned to switches 1...8 ).

The error messages in the I/O module and central unit are deleted, as soon as the errors have been corrected, if no further errors exist **and** when the error correction has been acknowledged.

Acknowledgement of an error after error correction:

- by pressing the test button for about 5 seconds, or
- by the PLC program, or
- by the PC.

Note:

The short-circuit and overload message indicates which channel has got the error.

The error message refers to a group of 4 outputs. This means, a short-circuit on one single channel (channel 0, 1, 2 or 3) is indicated as an error for all 4 channels (the whole group). The diagnosis message sent to the PLC always contains the first channel of the channel group, in this case channel 0.

After conclusion of the diagnosis interrogation, the 32 green and yellow LEDs again show the signal status of the channels.

## Technical Data for 07 DC 91

In general, the technical system data listed under "System data and system configuration" in chapter 1 of volume 2 of the "Advant Controller 31" system description are valid. Additional data or data which are different from the system data are listed as follows.

### Technical data of the complete unit

Permissible temperature range during operation	0...55 °C
Rated supply voltage	24 V DC
Rated signal voltage for inputs and outputs	24 V DC
Max. current consumption without load	0.15 A
Max. rated load for supply terminals	4.0 A
Max. power dissipation in module (outputs without load)	5 W
Max. power dissipation in module (outputs under load)	10 W
Protection against reversed polarity of power connection	yes
Conductor cross section for removable connectors	
power input	max. 2.5 mm <sup>2</sup>
CS31 system bus	max. 2.5 mm <sup>2</sup>
signal terminals	max. 1.5 mm <sup>2</sup>
Number of binary inputs	16
Number of binary transistor outputs	8
Number of configurable inputs and outputs	8
Reference potential for all inputs and outputs	Terminals 24/25 (minus pole of supply voltage, terminal M)
Number of interfaces	1 CS31 system bus interface
Electrical isolation	CS31 system bus interface against the rest of the unit
Address setting	Coding switch under the slide cover located on the right side of the housing
Diagnosis	see chapter "Diagnosis and displays"
Operation and error messages	a total of 33 LEDs

### Technical data of the digital inputs

Number of channels per unit	16
Distribution of channels in groups	2 groups of 8 channels each, channels En,00...En,07, and En,08...En,15
Reference potential for all inputs	Terminals 24/25 (minus pole of supply voltage, terminal M)
Electrical isolation	from CS31 system bus
Input delay	typ. 7 ms
Signalization of input signals	one green LED per channel, LED activated according to the input signal
Input signal voltage	24 V DC
0 signal	- 30 V...+ 5 V
1 signal	+ 13 V...+ 30 V
residual ripple at 0 signal	within - 30 V...+ 5 V
at 1 signal	within + 13 V...+ 30 V

Input current per channel	
Input voltage = + 24 V	typ. 7.0 mA
Input voltage = + 5 V	≥ 1.0 mA
Input voltage = + 13 V	≥ 2.0 mA
Input voltage = + 30 V	≤ 9.0 mA
Conductor cross section for removable connectors	max. 1.5 mm <sup>2</sup> (grid space 3.81 mm)

### Technical data of digital outputs

Number of channels per unit	8 transistor outputs
Distribution of channels in groups	1 group of 8 channels channels An,00...An,07
Reference potential for all inputs	Terminals 24/25 (minus pole of supply voltage, terminal M)
Common voltage supply terminals for all outputs	Terminals 22/23 (plus pole of supply voltage, terminal L+)
Electrical isolation	from CS31 system bus
Signalization of output signals	one yellow LED for each channel, LED activated according to output signal
Output current	
nominal value	500 mA at L+ = 24 V
maximum value	4 A total current per group
leakage current at 0 signal	< 0.5 mA
De-magnetization during inductive load	via internal varistor
Switching frequency at inductive load	max. 0.5 Hz
Switching frequency with lamps	max. 11 Hz at max. 5 W
Protection against short-circuit/overload	yes
overload message ( $I \geq 0.7$ A)	yes, after approx. 100 ms
limiting of output current	yes
reactivation after short-circuit/overload	automatically
Resistance to feedback against 24V signals	yes
Total load current (including output current of configured inputs and outputs)	max. 8 A
Conductor cross section for removable connectors	max. 1.5 mm <sup>2</sup> (grid space 3.81 mm)

### Technical data of configurable inputs and outputs

The configurable channels are defined individually by the user program as either inputs or outputs. This is done by reading or writing data to/from the respective channel.

Number of channels per unit	8 inputs / transistor outputs
Distribution of channels in groups	1 group of 8 channels
when using channels as inputs	channels En+1,00...En+1,07
when using channels as outputs	channels An,08...An,15
Signalization of input and output signals	one yellow LED per channel, LED activated according to binary signal
Technical data when used as outputs	refer to digital outputs

## Technical data when used as inputs

Input current per channel	refer to digital inputs
Input signal voltage	24 V DC
0 signal	- 6 V...+ 5 V *
1 signal	+ 13 V...+ 30 V
residual ripple at 0 signal	within - 6 V...+ 5 V *
at 1 signal	within + 13 V...+ 30 V

\* Due to the direct connection to the output, the demagnetizing varistor is also effective at the input when disconnecting inductive loads (see figure). This is why the difference between UPx and the input signal may not exceed the clamp voltage of the varistor. The varistor limits the voltage to approx. 36 V. Following this, the input voltage must range from - 12 V to + 30 V when UPx = 24 V and from - 6 V to + 30 V when UPx = 30 V.

The following figure shows the circuit arrangement of a digital input/output.

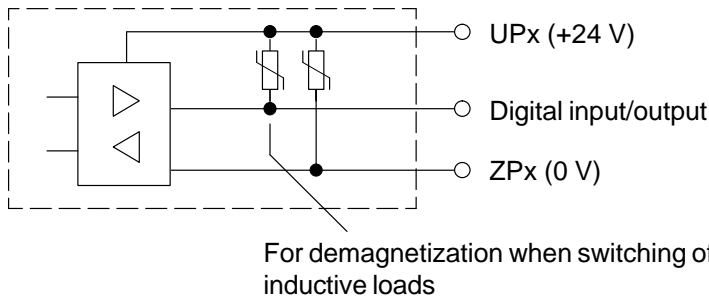

## Connection to the CS31 system bus

Interface standard	EIA RS-485
Electrical isolation	against voltage supply, input and output
Conductor cross section for removable 3-pole connector	max. 2.5 mm <sup>2</sup>

## Mechanical data

Mounting to DIN rail	according to DIN EN 50022-35, 15 mm deep. The DIN rail is centrally positioned between upper and lower edges of the module.
Mounting with screws	by 4 screws M4
Width x height x depth	120 x 140 x 85 mm
Connector conductor cross section	removable connectors with screw-type terminals max. 2.5 mm <sup>2</sup> (grid space 5.08 mm) max. 1.5 mm <sup>2</sup> (grid space 3.81 mm)
Weight	450 g
Dimensions for installation	refer to figure on next page

## Installation instructions

Installation position	vertical with connectors pointing up and down
Cooling	The natural convection cooling must not be hindered by cable ducts or other additional components installed in the cabinet.

## Ordering data

Module 07 DC 91	Order No. GJR5 2514 00 R0202
Scope of delivery	Digital input/output module 07 DC 91 1 5-pin connector (grid space 5.08 mm) 1 3-pin connector (grid space 5.08 mm) 4 9-pin connectors (grid space 3.81 mm)

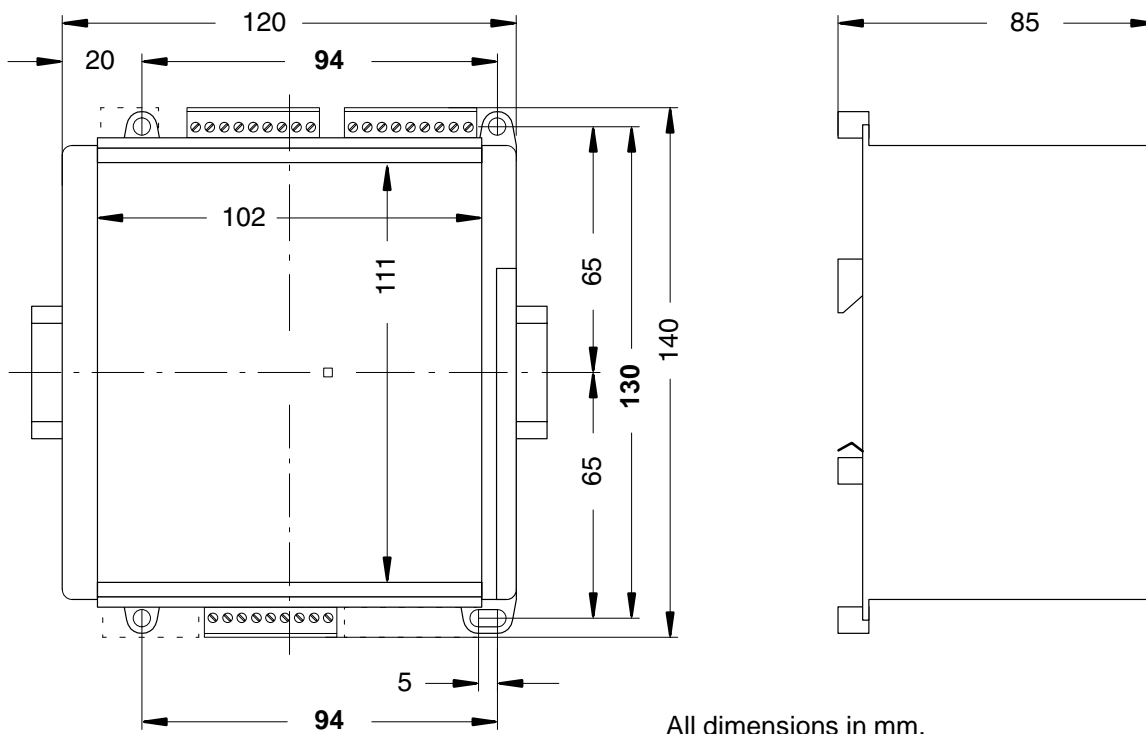
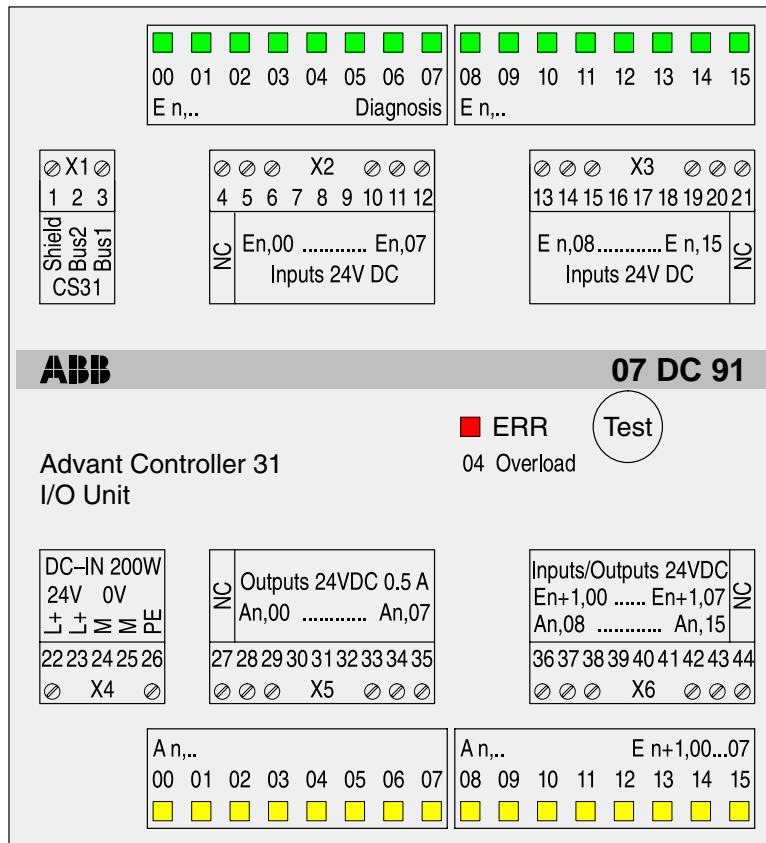

The depth of the module is 85 mm. If a DIN rail is used, the installation depth must be increased by the dimension of the rail.

Fig. 4.7-5: 07 DC 91, Front panel foil and outside dimension  
**Dimensions for installation holes are shown in bold print**



## 4.8 Digital Input/Output Module 07 DC 92

32 configurable digital inputs/outputs, 24 V DC, electrically isolated in groups, outputs can be loaded with 500 mA, CS31 system bus

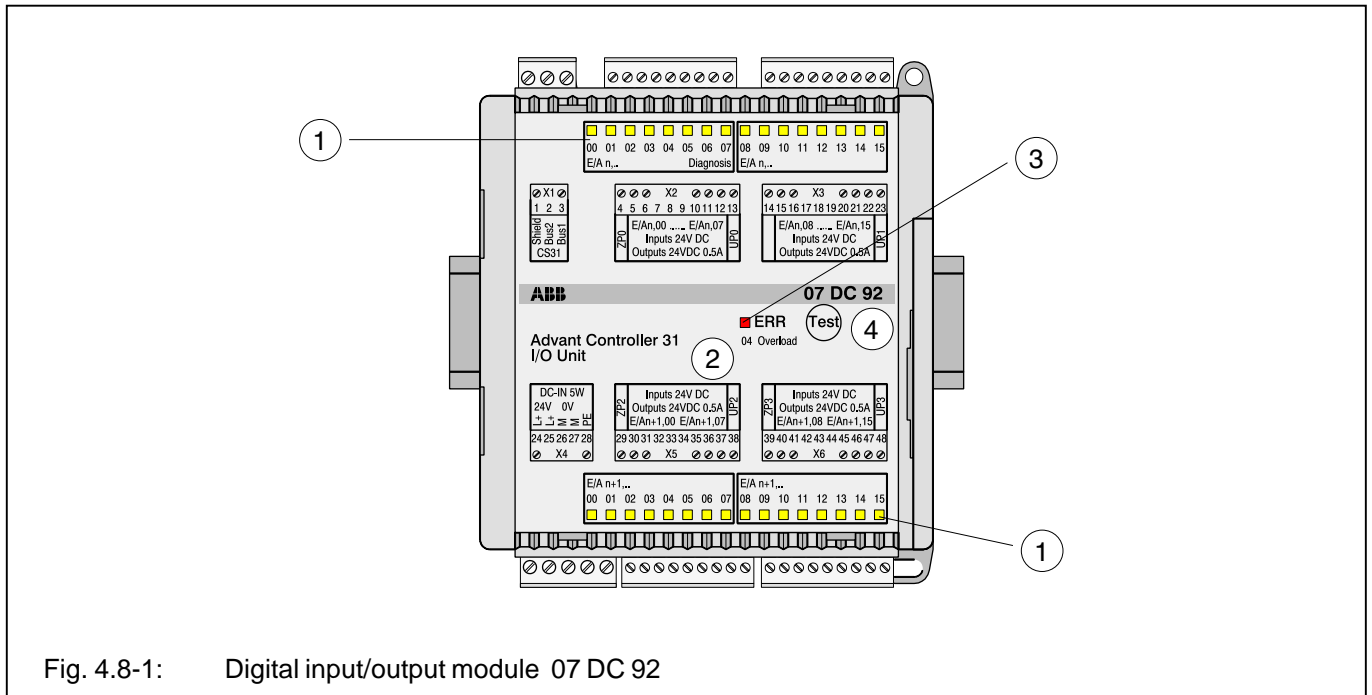

Fig. 4.8-1: Digital input/output module 07 DC 92

### Contents

Intended purpose .....	4.8-1
Display and operating elements on the front panel .....	4.8-1
Electrical connection .....	4.8-1
Addressing .....	4.8-3
Acknowledging outputs after a short circuit .....	4.8-3
Input/output configuration .....	4.8-3
Normal operation .....	4.8-3
Diagnosis and display .....	4.8-4
Technical Data .....	4.8-5
Dimensions for installation .....	4.8-8

### Intended purpose

The digital input/output module 07 DC 92 is used as a remote module on the CS31 system bus. It contains 32 inputs/outputs, 24 V DC, in 4 groups with the following features:

- The inputs/outputs can be accessed individually
  - as input,
  - as output or
  - as re-readable output (combined input/output)
- The outputs
  - work with transistors,
  - have a nominal load rating of 0.5 A and
  - are protected against overload and short circuit.

- The 4 groups of inputs/outputs are electrically isolated from each other and from the rest of the unit.
- The module occupies two digital addresses for inputs and outputs on the CS31 system bus. It is possible to configure the unit solely as an output module. In this case, the addresses for the inputs are not needed.

The unit works with a supply voltage of 24 V DC.

The system bus connection is electrically isolated from the rest of the unit.

The module offers a number of diagnosis functions (see chapter "Diagnosis and displays").

### Displays and operating elements on the front panel

- ① 32 yellow LEDs to indicate the signal status of the configurable inputs and outputs
- ② List of diagnosis information concerning the LEDs when they are used for diagnosis display
- ③ Red LED for error message
- ④ Test button

### Electrical connection

The module can be mounted on a DIN rail (height 15 mm) or with 4 screws. The following figure shows the electrical connection of the input/output module.

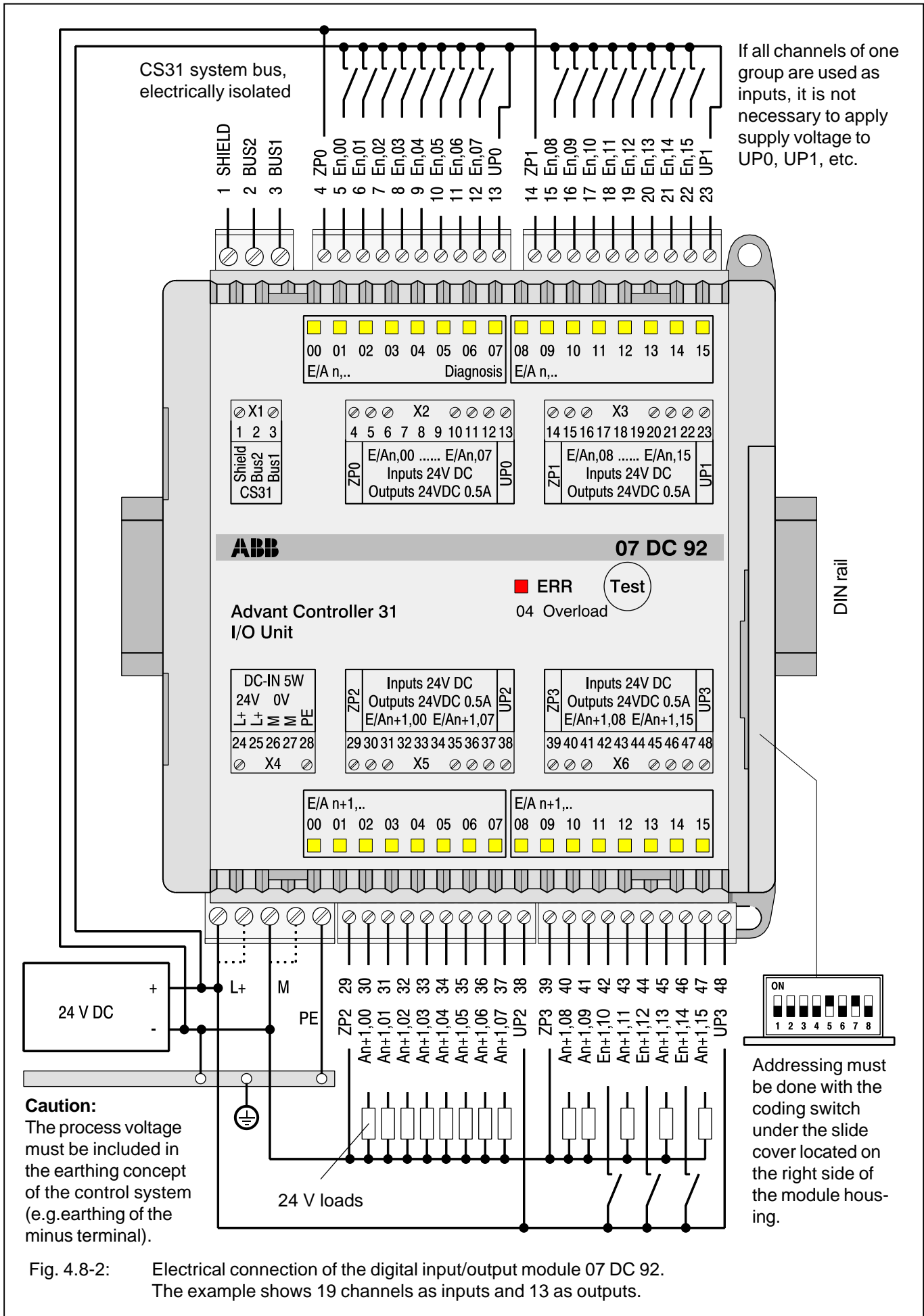

Fig. 4.8-2: Electrical connection of the digital input/output module 07 DC 92. The example shows 19 channels as inputs and 13 as outputs.

## Addressing

An address must be set for each module to enable the central unit to correctly access the inputs and outputs.

**A detailed description about "Addressing" can be found in the chapter "Addressing" for the central processing unit and coupler.**

The address setting is accomplished with the DIL switch located under the slide cover on the right side of the module housing.

When using central units 07 KR 91 or 07 KT 9x as bus master, the following **possibilities** (address assignments) are offered, depending on the setting of the address DIL switch No. 1:

Central units 07 KR 91 / 07 KT 9x		
If the address DIL switch <b>No. 1</b> is set to <b>OFF</b> , all 32 channels can be used individually as inputs or outputs. DIL switch 8 is not used.		
Terminal	Input	Output
5	E n,00	A n,00
6	E n,01	A n,01
7	E n,02	A n,02
8	E n,03	A n,03
9	E n,04	A n,04
10	E n,05	A n,05
11	E n,06	A n,06
12	E n,07	A n,07
15	E n,08	A n,08
16	E n,09	A n,09
17	E n,10	A n,10
18	E n,11	A n,11
19	E n,12	A n,12
20	E n,13	A n,13
21	E n,14	A n,14
22	E n,15	A n,15
30	E n+ 1,00	A n+1,00
31	E n+ 1,01	A n+1,01
32	E n+ 1,02	A n+1,02
33	E n+ 1,03	A n+1,03
34	E n+ 1,04	A n+1,04
35	E n+ 1,05	A n+1,05
36	E n+ 1,06	A n+1,06
37	E n+ 1,07	A n+1,07
40	E n+ 1,08	A n+1,08
41	E n+ 1,09	A n+1,09
42	E n+ 1,10	A n+1,10
43	E n+ 1,11	A n+1,11
44	E n+ 1,12	A n+1,12
45	E n+ 1,13	A n+1,13
46	E n+ 1,14	A n+1,14
47	E n+ 1,15	A n+1,15

Fig. 4.8-3: Addresses of channels (channel numbers) when the DIL switch No. 1 is switched to OFF

Item **n** in the table designates the module address that can be set with the address DIL switch with switches 2...7.

When using 07 KR 91 / 07 KT 9x as bus master, we recommend to use even-numbered module addresses (08, 10, 12.....60).

In this setting, (**DIL switch 1 in OFF position** = factory setting) the module occupies **two** addresses for inputs and outputs.

If the **DIL switch 1 is set to ON**, the unit is configured solely as an output module. In this case, the addresses for inputs are not needed.

Note:

Module 07 DC 92 reads the setting of the address switch **only** during initialization, after switching on the power supply, meaning that changes of the setting during operation remain ineffective until the next initialization process.

### Acknowledging outputs after a short-circuit

When an overload or short-circuit occurs, the output limits the current and thermally switches it off. The LED of the overloaded output is flashing.

After the overload or short-circuit is corrected, the outputs are switched on again automatically. A manual acknowledgement or one initiated by the user program is not necessary. The error message has to be acknowledged.

### I/O configuration

Module 07 DC 92 does not store configuration data. The 32 configurable channels are defined by the user program as inputs or outputs, which means that through reading and writing data in the user program, each configurable input/output channel can be used as input, output, or re-readable output.

### Normal operation

- The module automatically initializes after the power has been switched on. During that time, all LEDs are switched on.
- When the CS31 system bus does not run, LED ③ flashes.
- LED ③ goes out again when the bus operation runs correctly and the module does not recognize an error.
- The 32 yellow LEDs ① show the signal status of the 32 channels.

## Diagnosis and displays

Diagnosis functions:

- Short-circuit/overload of outputs ( $I > 0.7 \text{ A}$ )
- Reporting of a short-circuit or overload condition to the central unit and flashing of the corresponding LED
- Storing and making this information available for recall (kind of error and location of error)
- Error inside of module
- Error on CS31 system bus

If one of these errors occur, the red LED ③ will light up.

**The error message will be reported to the central unit or to the coupler.** For additional information refer to chapter "Diagnosis" for these devices.

A direct diagnosis inquiry can be made with the test button ④ and the upper LED displays ①.

By pressing the test button once, the channel E/A n, **00** is selected: the status LED of the selected input flashes while all other status indicators are switched off during the test. After releasing the test button, the diagnosis information for this channel is displayed for about 3 seconds by the upper yellow LEDs 00 to 07.

Explanation of the lit LEDs:

- 00 not used
- 01 not used
- 02 not used
- 03 not used
- 04 Overload or short-circuit, only for outputs
- 05 not used
- 06 not used
- 07 not used

The explanation of the LEDs ② is also printed on the front panel.

The procedure is repeated for the other input and output channels with each successive pressing and releasing of the test button.

After accessing the last channel, another pressing of the test button initiates an LED test. All LEDs must light up. Following that, the position of the address switch is displayed by LEDs 00 to 07 for about 3 seconds which was set by module 07 DC 92 during the initialization. In this case LED 00 shows the setting of switch 1 (LEDs 0...7 are assigned to switches 1...8).

The error messages at the I/O module and at the central control unit go out as soon as the errors have been corrected, no new errors exist **and** the error correction has been acknowledged.

Acknowledging an error after error correction:

- by pressing the test button for about 5 seconds or
- by the PLC program, or
- by the PC.

Notes:

The short-circuit and overload display can indicate in which group of 8 channels the error has occurred.

The error message to the PLC is as follows:

Overload in group 00...07	Channel 00 is reported
Overload in group 08...15	Channel 08 is reported
Overload in group 16...23	Channel 15 is reported
Overload in group 24...31	Channel 15 is reported

After the diagnosis interrogation has finished, the 32 yellow LEDs again show the signal status of the channels.

## Technical Data for 07 DC 92

In general, the technical system data listed under "System data and system configuration" in chapter 1 of volume 2 of the "Advant Controller 31" system description are valid. Additional data or data which are different from the system data are listed as follows.

### Technical data of the complete unit

Permissible temperature range during operation	0...55 °C
Rated supply voltage	24 V DC
Rated signal voltage for inputs and outputs	24 V DC
Max. current consumption without load	0.15 A
Max. rated load for supply terminals	4.0 A
Max. power dissipation in module (outputs without load)	5 W
Max. power dissipation in module (outputs under load)	10 W
Protection against reversed polarity of power connection	yes
Conductor cross section for the removable connectors	
power supply	max. 2.5 mm <sup>2</sup>
CS31 system bus	max. 2.5 mm <sup>2</sup>
signal terminals	max. 1.5 mm <sup>2</sup>
supply for I/O groups	max. 1.5 mm <sup>2</sup>
Number of configurable inputs/outputs	32 (the configurable channels are defined individually by the user program to be either inputs or outputs. This is accomplished by interrogating or assigning the appropriate channel).
Electrical isolation CS31 system bus inputs/outputs	from the rest of the unit group from group, all groups from the rest of the unit
Supply of the I/O groups	each group is supplied individually, see Fig. 4.8-2
Number of interfaces	1 CS31 system bus interface
Address setting	Coding switch located under the slide cover at the right side of the housing
Diagnosis	see chapter "Diagnosis and display"
Operation and error displays	a total of 33 LEDs

### Technical data of the I/O channels as binary inputs

Number of channels per unit	32
Division of channels into groups	4 groups with 8 channels each, channels En,00...En,07 and En,08...En,15 channels En+1,00...En+1,07 and En+1,08...En+1,15
Reference potential for inputs	ZP0, ZP1, ZP2 and ZP3
Electrical isolation	group from group, all groups from the rest of the unit
Input delay	typ. 7 ms
Signalization of the input signals	one yellow LED per channel, LED activated according to the input signal

Input signal voltage	24 V DC	
0 signal (when UPx connected)	- 6 V...+ 5 V	*
0 signal (when UPx not connected)	- 30 V...+ 5 V	
1 signal	+ 13 V...+ 30 V	
residual ripple at 0 signal (UPx connected)	within - 6 V...+ 5 V	*
at 0 signal (UPx not connected)	within - 30 V...+ 5 V	
at 1 signal	within + 13 V...+ 30 V	

\* Due to the direct connection to the output, the demagnetizing varistor is also effective at the input when disconnecting inductive loads (see figure). This is why the difference between UPx and the input signal may not exceed the clamp voltage of the varistor. The varistor limits the voltage to approx. 36 V. Following this, the input voltage must range from - 12 V to + 30 V when UPx = 24 V and from - 6 V to + 30 V when UPx = 30 V.

When all 8 channels of the group are used as inputs and terminal UPx is not wired-up, there are no restrictions to the input signals. In this case, the input voltage can range from - 30 V to + 30 V. The following figure shows the circuit arrangement of a digital input/output.

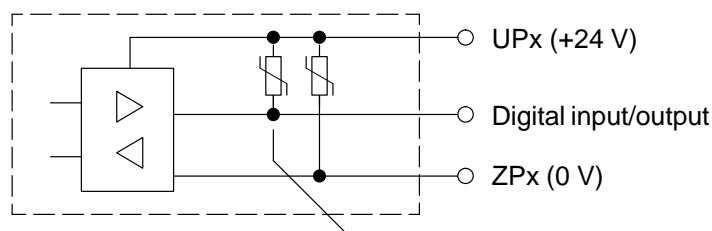

For demagnetization when switching off inductive loads

Input current per channel	
input voltage = + 24 V	typ. 7.0 mA
input voltage = + 5 V	≥ 0.2 mA
input voltage = + 13 V	≥ 2.0 mA
input voltage = + 30 V	≤ 9.0 mA

Conductor cross section for the removable connectors	max. 1.5 mm <sup>2</sup> (grid space 3.81 mm)
--	---

### Technical data of I/O channels as digital outputs

Number of channels per unit	32 transistor-outputs
Division of channels in groups	4 groups with 8 channels each, channels An,00...An,07 and An,08...An,15 channels An+1,00...An+1,07 and An+1,08...An+1,15
Reference potentials for outputs	ZP0, ZP1, ZP2 and ZP3
Voltage supply for outputs	UP0, UP1, UP2 and UP3
Electrical isolation	group from group, all groups from the rest of the unit
Signalization of output signals	one yellow LED per channel, LED activated according to the input signal
Output current	
nominal value	500 mA at L+ = 24 V
max. value	4 A total current for each group
leakage current at 0 signal	< 0.5 mA
Demagnetization at inductive load	via internal varistor
Switching frequency for inductive load	max. 0.5 Hz
Switching frequency for lamp load	max. 11 Hz at max. 5 W

Protection against short-circuit/overload	yes
overload message ( $I \geq 0,7 \text{ A}$ )	yes, after approx. 100 ms
limitation of output current	yes
reactivation after short-circuit/overload	automatically
Resistance to feedback against 24V signals	yes
Load current (total)	max. 4 A for each group
Conductor cross section for the removable connectors	max. 1.5 mm <sup>2</sup> (grid space 3.81 mm)
<b>Connection to the CS31 system bus</b>	
Interface standard	EIA RS-485
Galvanic separation	from supply voltage, inputs and outputs
Conductor cross section for the removable 3-pole connector	max. 2.5 mm <sup>2</sup>
<b>Mechanical data</b>	
Mounting to DIN rail	according to DIN EN 50022-35, 15 mm deep. The DIN rail is centrally positioned between upper and lower edges of the module.
Mounting with screws	by 4 screws M4
Width x height x depth	120 x 140 x 85 mm
Connector conductor cross section	removable connectors with screw-type terminals max. 2.5 mm <sup>2</sup> (grid space 5.08 mm) max. 1.5 mm <sup>2</sup> (grid space 3.81 mm)
Weight	450 g
Dimensions for installation	see figure on next page
<b>Installation instructions</b>	
Installation position	vertical with connectors pointing up and down
Cooling	The natural convection cooling must not be hindered by cable ducts or other additional components installed in the cabinet.
<b>Ordering data</b>	
Module 07 DC 92	Order No. GJR5 2522 00 R0101
Scope of delivery	Digital Input and output module 07 DC 92 1 5-pin connector (grid space 5.08 mm) 1 3-pin connector (grid space 5.08 mm) 4 10-pin connectors (grid space 3.81 mm)

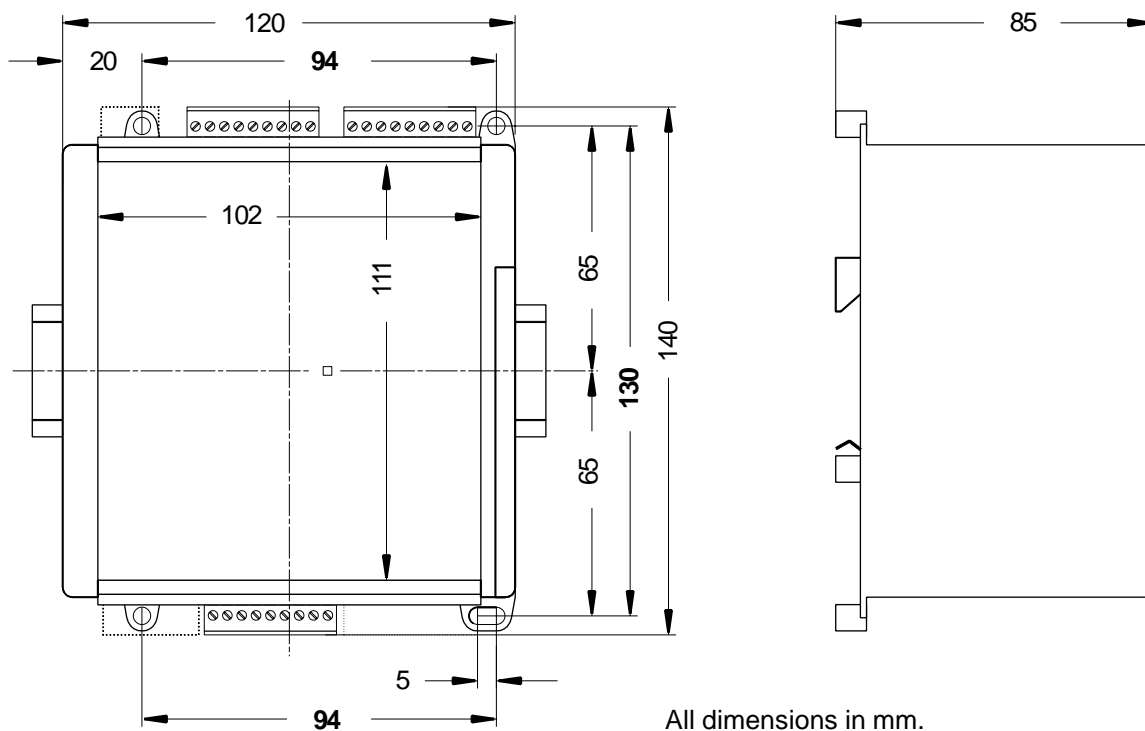
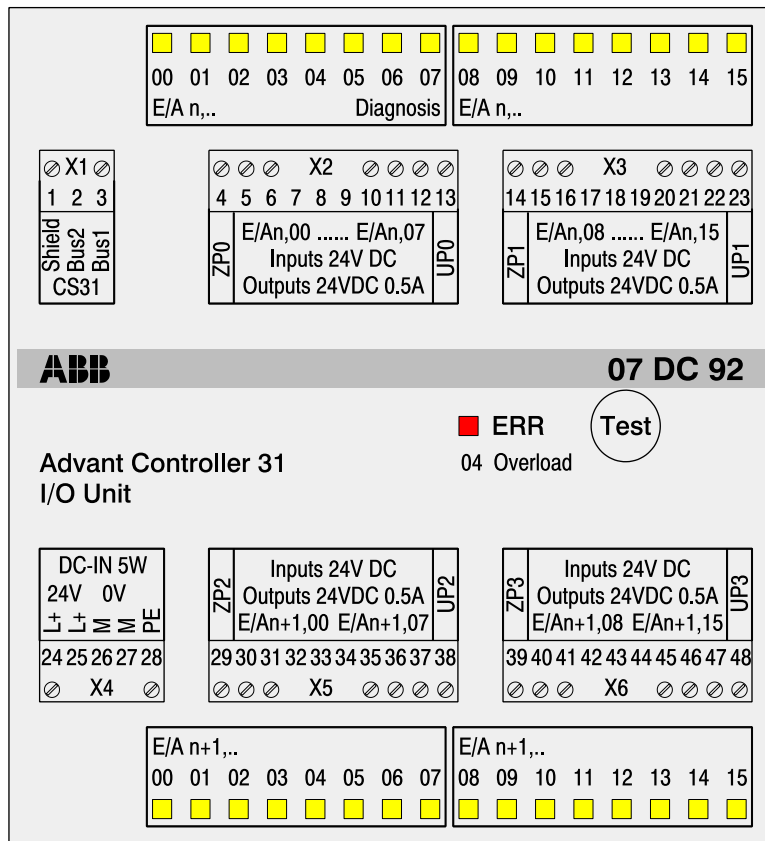

The depth of the module is 85 mm. If a DIN rail is used, the installation depth must be increased by the dimension of the rail.

Fig. 4.8-5: 07 DC 92, Front panel foil and outside dimensions.  
**Dimensions for installation holes are shown in bold print**



## 4.10 Keyboard Controller 07 TC 91

### 32 switches/keys and 32 LEDs controllable

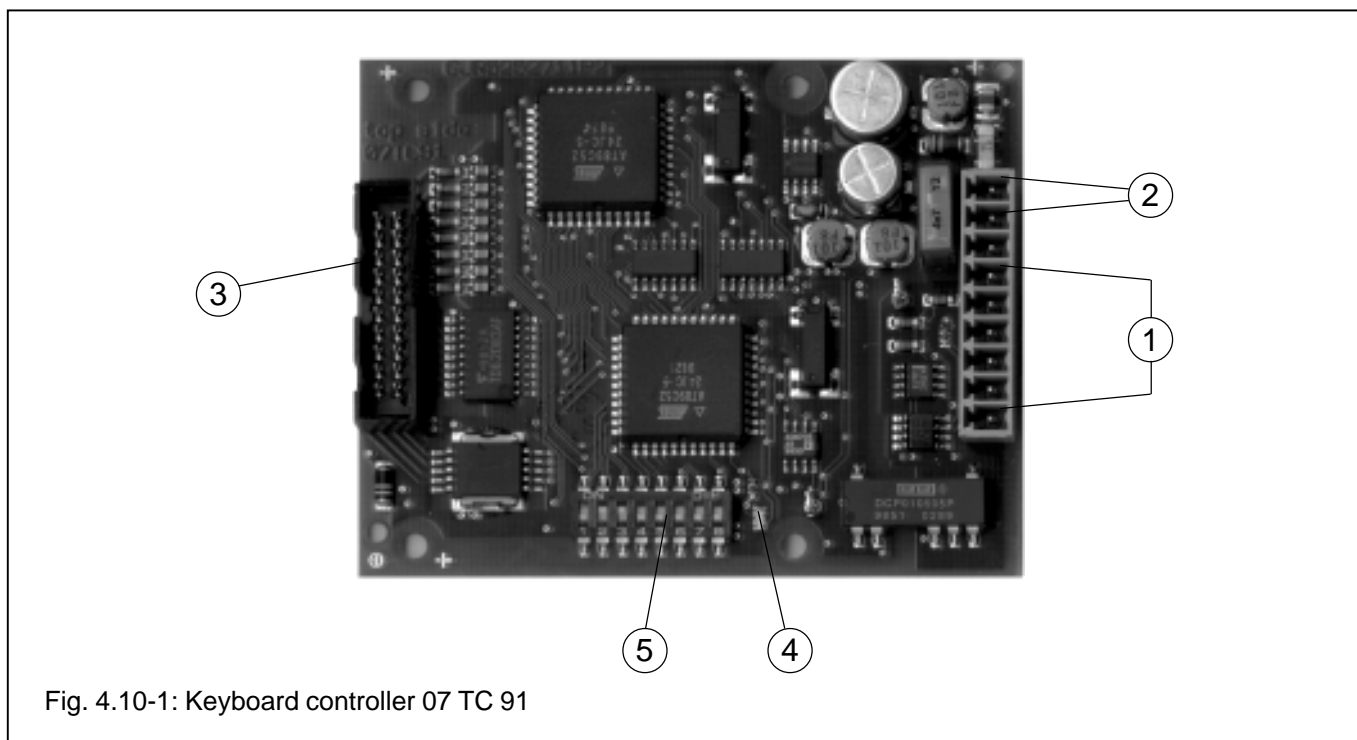

Fig. 4.10-1: Keyboard controller 07 TC 91

### Contents

Intended purpose .....	4.10-1
Displays and components on the printed circuit board .....	4.10-1
Electrical connection .....	4.10-1
Connector assignment of the multiplex interface .	4.10-2
Connector assignment of power supply and CS31 bus, mechanical dimensions .....	4.10-2
Connection diagram, connection of the switches/pushbuttons .....	4.10-3
Connection diagram, connection of the LEDs .....	4.10-4
Timing diagram for multiplex controlling of the LEDs and switches .....	4.10-5
Addressing .....	4.10-5
Diagnosis .....	4.10-5
Technical data .....	4.10-6
Mechanical dimensions, connector assignments .....	4.10-7
Appendix: Calculation of the LED resistors .....	4.10-8

### Intended purpose

The module 07 TC 91 is used for coupling control panels consisting of pushbuttons or switches and LEDs to the CS31 system bus. These control panels should be connectable to the CS31 system bus without large expenditure of wiring and software in the PLC.

The pushbuttons/switches and LEDs should preferably be connected via a printed circuit board (printed circuit board of the control panel manufacturer). The device 07 TC 91 is connected to this printed circuit board via a flat cable or a direct connector.

The mechanical connection can be made by means of the four mounting holes on the device.

The device 07 TC 91 can input or control up to 32 switches/pushbuttons and 32 LEDs which are arranged in 4x8 matrix. In the PLC software one digital input is assigned to every pushbutton/switch and one digital output to every LED. Multiplexing is carried out by the 07 TC 91.

The device behaves like a combined I/O module on the CS31 system bus. It presents all keys and LEDs as individual digital signals.

### Displays and components on the printed circuit board

- ① Interface to the CS31 system bus (basic housing for 9-pole plug-in type terminal)
- ② Power supply (basic housing for 9-pole plug-in type terminal)
- ③ Multiplex interface (20-pole pin block) for connecting the switches/pushbuttons and LEDs
- ④ Red LED for displaying the CS31 system bus status
- ⑤ Address switch

### Electrical connection

The 24 V DC power supply is carried out via 3 plug-in type poles on a 9-pole connector housing.

## Connector assignment of the multiplex interface

Terminal		Terminal	
1	Column input 7	2	Column input 6
3	Column input 5	4	Column input 4
5	Column input 3	6	Column input 2
7	Column input 1	8	Column input 0
9	Column driver 7	10	Column driver 6
11	Column driver 5	12	Column driver 4
13	Column driver 3	14	Column driver 2
15	Column driver 1	16	Column driver 0
17	Line driver 3	18	Line driver 2
19	Line driver 1	20	Line driver 0

Fig. 4.10-2: Connector assignment of the multiplex interface X2

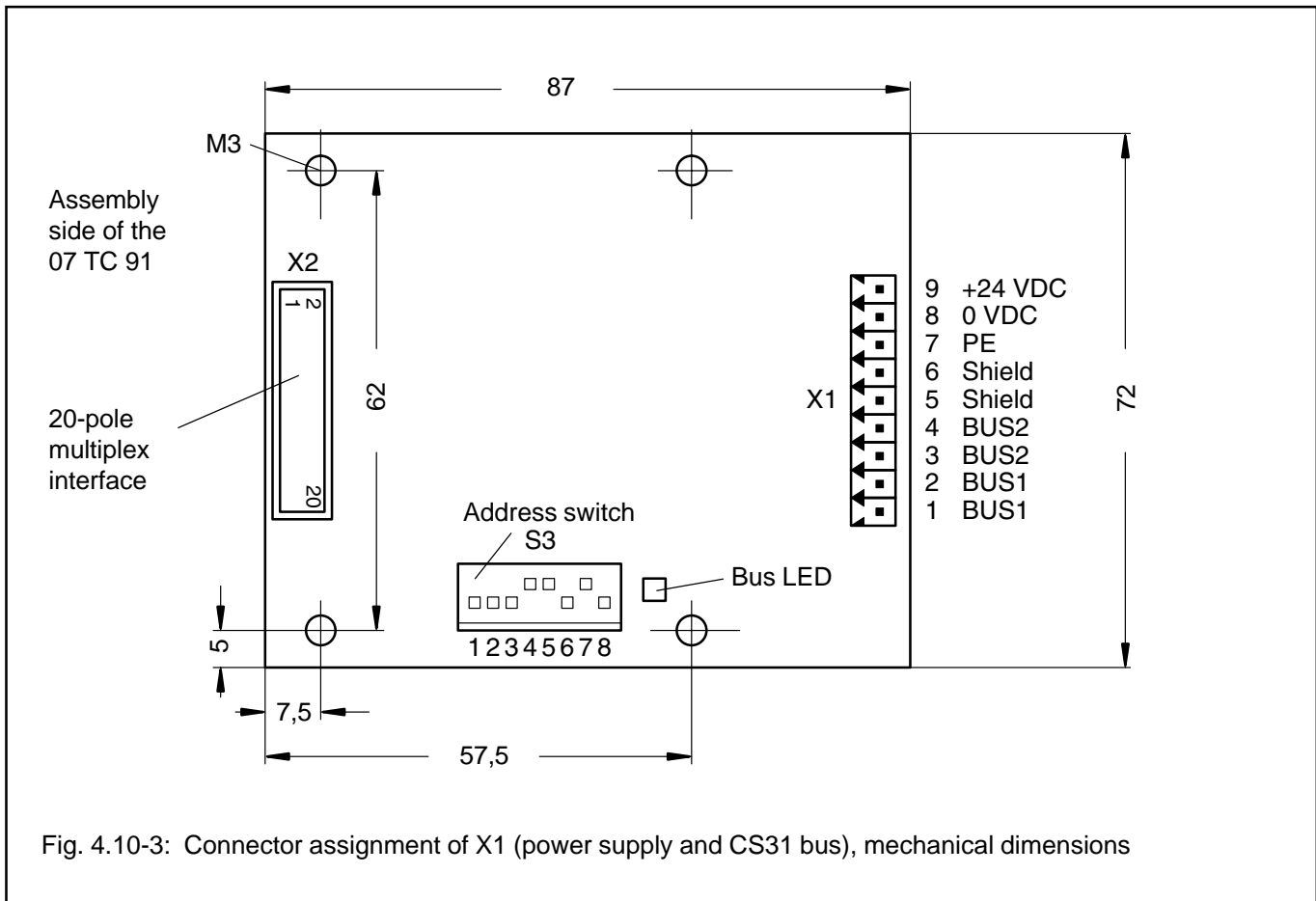

Fig. 4.10-3: Connector assignment of X1 (power supply and CS31 bus), mechanical dimensions

# Connection diagram, connection of the switches/pushbuttons

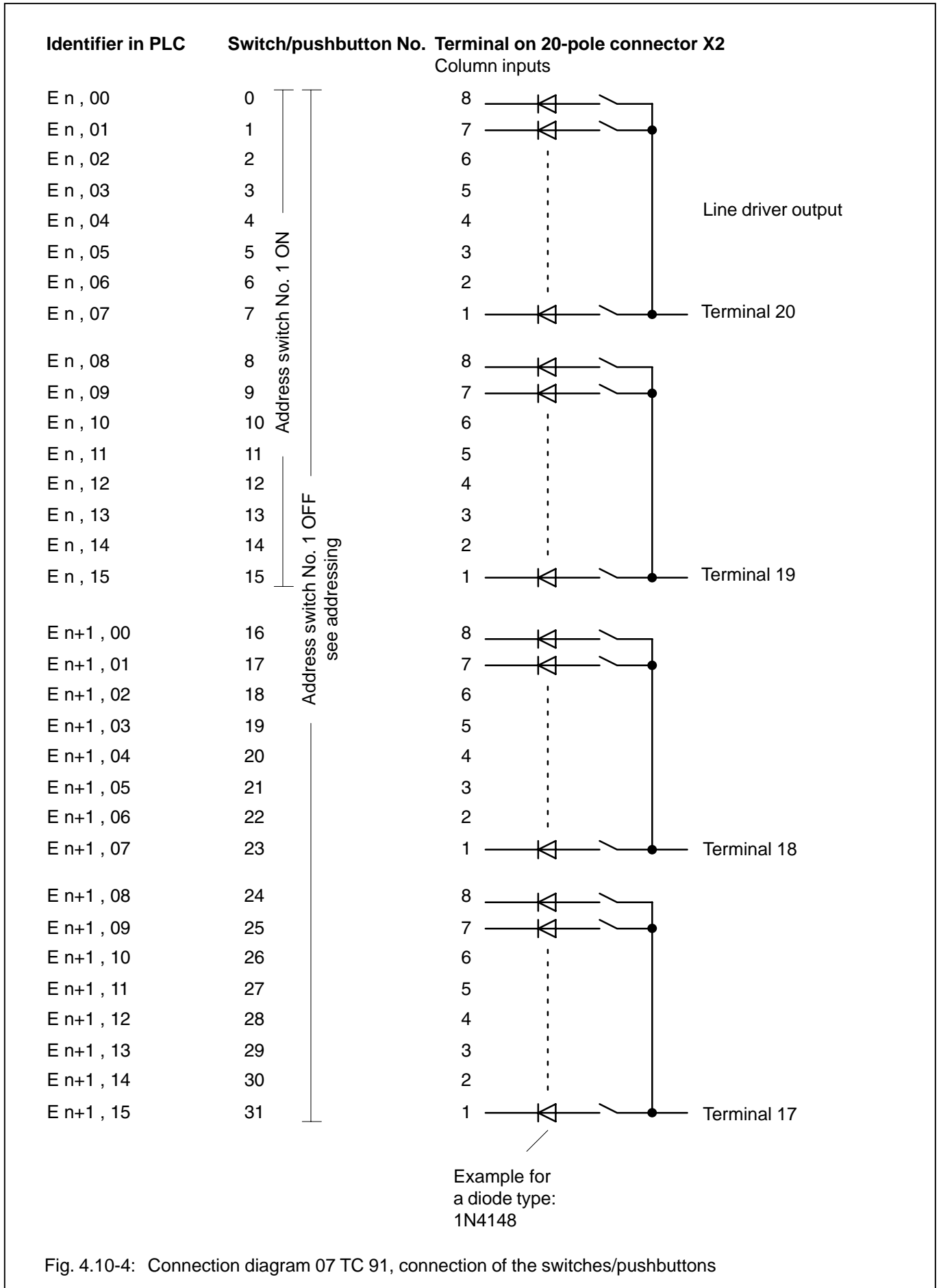

Fig. 4.10-4: Connection diagram 07 TC 91, connection of the switches/pushbuttons

## Connection diagram, connection of the LEDs

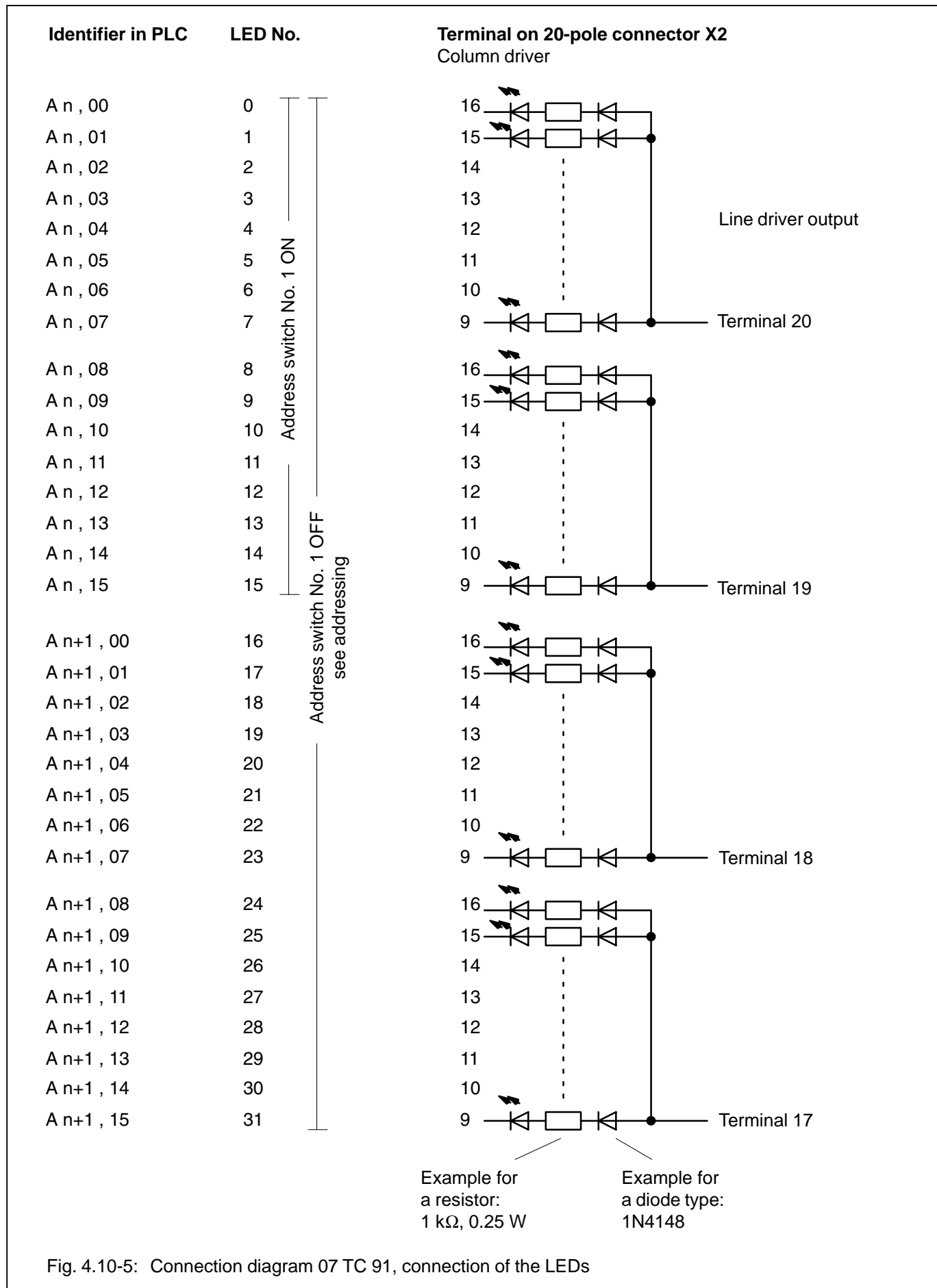
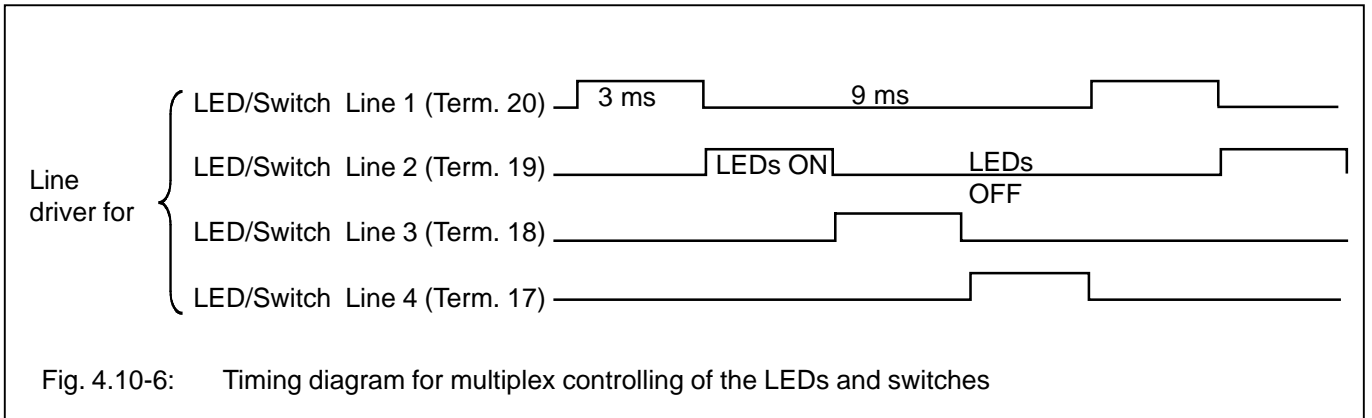
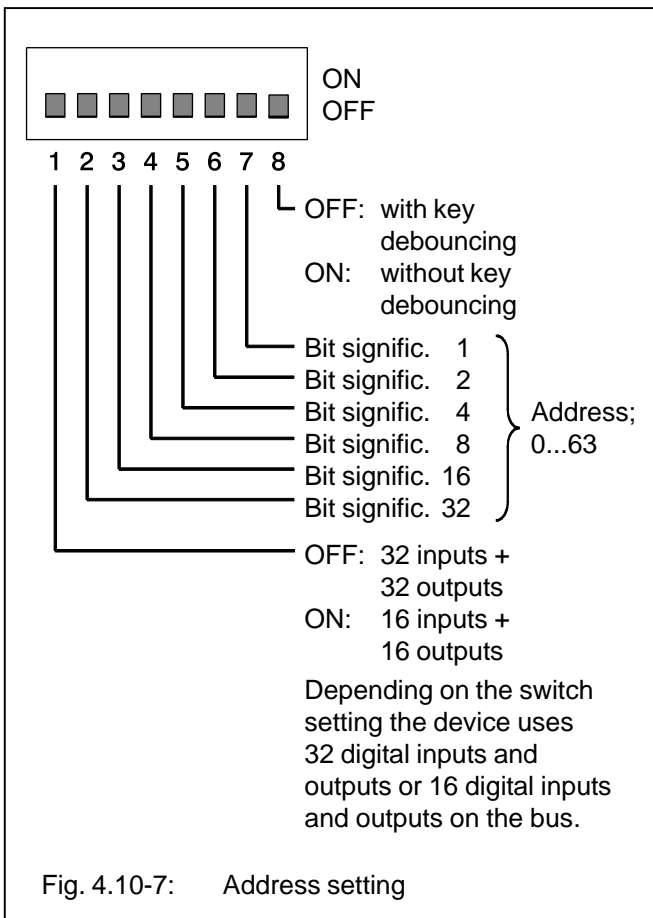

Fig. 4.10-5: Connection diagram 07 TC 91, connection of the LEDs

## Timing diagram for multiplex controlling of the LEDs and switches



## Addressing



## Diagnosis

### Red LED

- OFF: CS31 system bus is running
- flashes: CS31 system bus is not running, CS31 system bus not connected
- ON: Initialization phase after switching on the supply voltage

There are no other diagnosis and configuration possibilities via the CS31 system bus.

## Technical data

As far as possible, the AC31 system data are valid.

Exceptions:

- Open construction system, degree of protection IP00.
- The user is responsible for the appropriate installation and observance of the necessary degree of protection.

- The device cannot be used as I/O module for standard applications because of the multiplex method for the I/O signals.

Principally it should be taken into consideration that the EMC behaviour can be affected by the LED and key module connected via the flat cable.

After each reset function, the module performs a lamp test for a period of ca. 250 ms.

---

### Power supply

Device rated supply voltage	24 V DC
Max. current consumption	600 mA (including key and LED controlling)
Connector	Basic housing for 9-pole plug-in terminal see Fig. 4.10-8
Protection against reversed connected supply voltage	yes

### CS31 system bus interface

Interface standard	RS-485
Connector	Basic housing for 9-pole plug-in terminal see Fig. 4.10-8
Electrical isolation	CS31 system bus against the rest of the unit

### Multiplex interface

Line drivers	24 V DC 500 mA per line, short-circuit proof  Remark: The line current consists of the current for the LEDs via the column drivers and the input currents via the pushbuttons.
Column drivers	max. 50 mA, "Open Collector" Sum <500 mA (because of the line drivers)
Column inputs	24 V DC, 7 mA (typical), no input delay, but key debouncing by the software, can be disabled by switch, see Fig. 4.10-7 "Address setting"; debounce time: ca. 40 ms, without key debouncing the updating time is 1 multiplex cycle (approx. 12 ms) Min. high signal (at 24 V DC supply voltage) $U_{L_{min.}} = 16 \text{ V}$ referred to internal 0 V, corresponds to 3.4 mA input current Max. low signal (at 24 V DC supply voltage) $U_{L_{max.}} = 6 \text{ V}$ referred to internal 0 V, corresponds to 1.3 mA input current
Matrix	4 lines with 8 columns for pushbuttons/switches and 8 columns for LEDs
Multiplex frequency	approx. 83 Hz; 3 ms pulse / 9 ms interval
Connector	20-pole pin block with twisting protection, suitable for flat cable; grid spacing 2.54 mm; according to DIN 41651
Displays	red LED for CS31 system bus status

## Mechanical dimensions, connector assignment

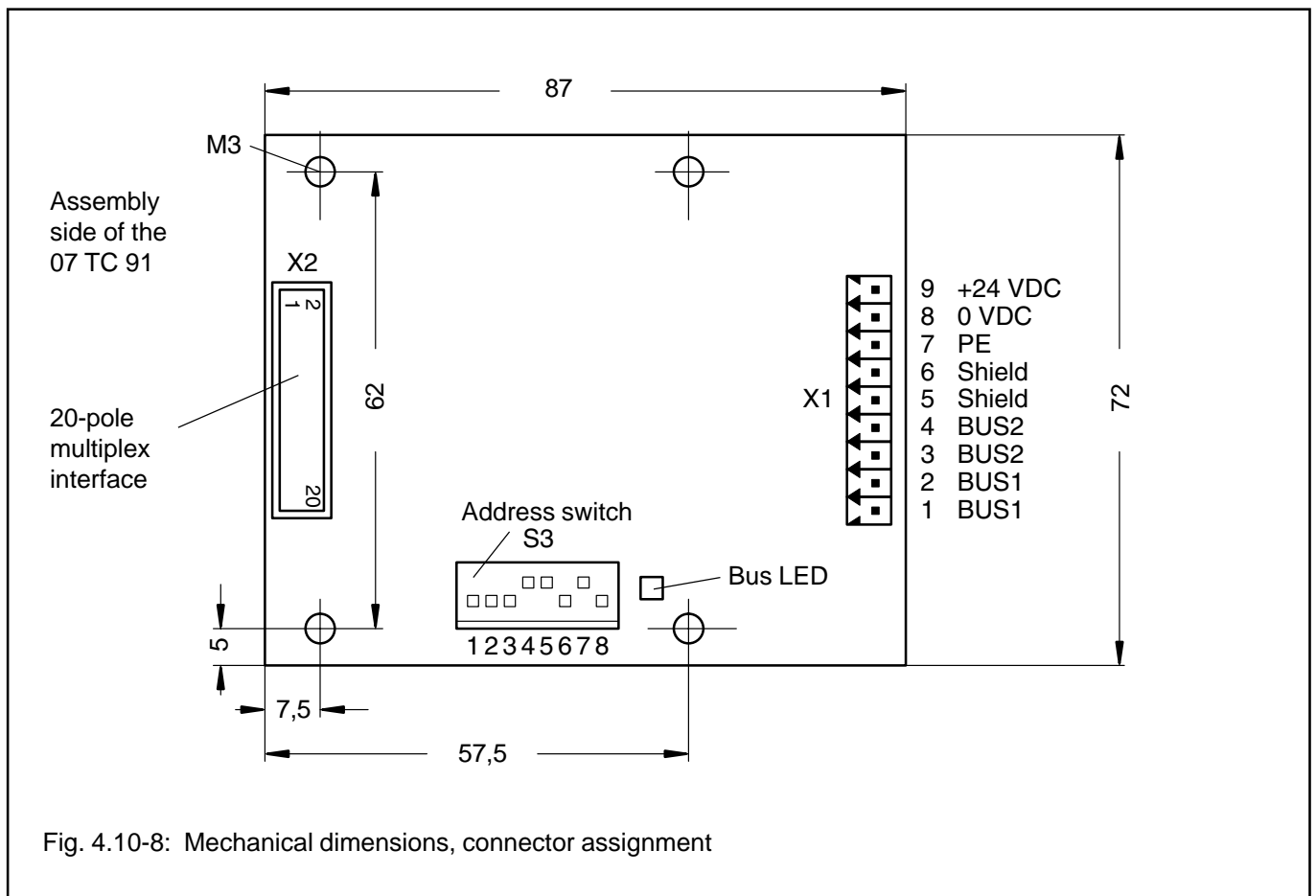

Dimensions

87 mm x 72 mm x 30 mm (length x width x height)

Weight

ca. 0.1 kg

### Ordering data

07 TC 91

GJR5 2527 00 R0101

### Note:

A corresponding counterpart is required for the 9-pole connector basic housing (not supplied as standard accessory). Several manufacturers, e.g. Phönix, Wago, Weidmüller, offer this plug-in component in various versions (straight or bended, as screw-type terminal or cage tension spring terminal).

The Phönix name for the 9-pole connector basic housing (pin grid space 3.81 mm) used for the keyboard controller 07 TC 91 is:

COMBICON basic housing EMCV 1,5/9-G-3,81  
Part No. 1860 715

The corresponding screw-type terminal would be e.g.:  
Phönix MC 1,5/9-ST-3,81GY, Part No. 1883 666.

## Appendix: Calculation of the LED resistors

- The typical current in the column input is 7 mA, maximum 10 mA.
- The line driver is loaded via the switches/pushbuttons with max. 8 column inputs simultaneously.
- The maximum load-carrying capacity of a line driver is 500 mA. If the load caused by the column inputs is subtracted (80 mA max.), max. 420 mA remain for controlling the LEDs.
- A line driver must be able to drive max. 8 LEDs at the same time. For this purpose,  $420 \text{ mA}/8 = 52.5 \text{ mA}$  per LED are available. The 8 column drivers are loadable with max. **50 mA** each.
- The voltage drops (LED + diode + saturation voltage of the drivers) are approx. 4 V. The maximum supply voltage is 30 V. The maximum voltage at the resistor is  $30 \text{ V} - 4 \text{ V} = \mathbf{26 \text{ V}}$ .
- Thus, the minimum LED resistor is

$$R_{\text{LEDmin}} = \frac{26 \text{ V}}{50 \text{ mA}} = \underline{\underline{0.520 \text{ k}\Omega}}$$

- The next higher value of a standard resistor is **560  $\Omega$** . When switched on, the current flowing through this resistor is

$$I_{\text{LEDmax}} = \frac{26 \text{ V}}{560 \Omega} = \underline{\underline{46.4 \text{ mA}}}$$

- Due to the multiplex method, the effective LED current is only  $\frac{1}{4}$  of the impulse current of 46.4 mA max. The maximum brightness of the LEDs corresponds with the brightness of LEDs which are continuously operated with  $46.4 \text{ mA}/4 = 11.6 \text{ mA}$ .
- The maximum power dissipation at the 560  $\Omega$  resistor is calculated with the following formula

$$P_V = \frac{U_{\text{max}} \cdot I_{\text{max}}}{4}$$

$$P_V = \frac{26 \text{ V} \cdot 46.4 \text{ mA}}{4} = \underline{\underline{302 \text{ mW}}}$$

- The following table shows the calculation results for different resistors:

$R_{\text{LED}}$	560 $\Omega$	680 $\Omega$	1 k $\Omega$	1,5 k $\Omega$	2.2 k $\Omega$
Rated im-pulse current $L+ = 24 \text{ V}$	35.7 mA	29.4 mA	20 mA	13.3 mA	9.1 mA
Active LED-current $L+ = 24 \text{ V}$	8.9 mA	7.4 mA	5 mA	3.3 mA	2.3 mA
Max. im-pulse current $L+ = 30 \text{ V}$	46.4 mA	38.2 mA	26 mA	17.3 mA	11.8 mA
Max. power dissipation $L+ = 30 \text{ V}$	302 mW	249 mW	169 mW	113 mW	77 mW
Resistor type	$\geq 0.5 \text{ W}$	$\geq 0.33 \text{ W}$	$\geq 0.25 \text{ W}$	$\geq 0.25 \text{ W}$	$> 0.125 \text{ W}$

### Formulas for calculating the table values:

- Rated impulse current,  $L+ = 24 \text{ V}$

$$I_{\text{imp}} = \frac{24 \text{ V} - 4 \text{ V}}{R_{\text{LED}}}$$

- Active LED current,  $L+ = 24 \text{ V}$

$$I_{\text{wirk}} = \frac{I_{\text{imp}}}{4}$$

- Maximum impulse current,  $L+ = 30 \text{ V}$

$$I_{\text{imp,max}} = \frac{30 \text{ V} - 4 \text{ V}}{R_{\text{LED}}}$$

- Maximum power dissipation

$$P_{\text{max}} = \frac{I_{\text{imp,max}} \cdot (30 \text{ V} - 4 \text{ V})}{4}$$

- Resistor type selected



## 4.12 Digital Input Module 07 DI 93-I

16 input channels 24 V DC, **degree of protection IP67**,  
electrically isolated CS31 system bus connection

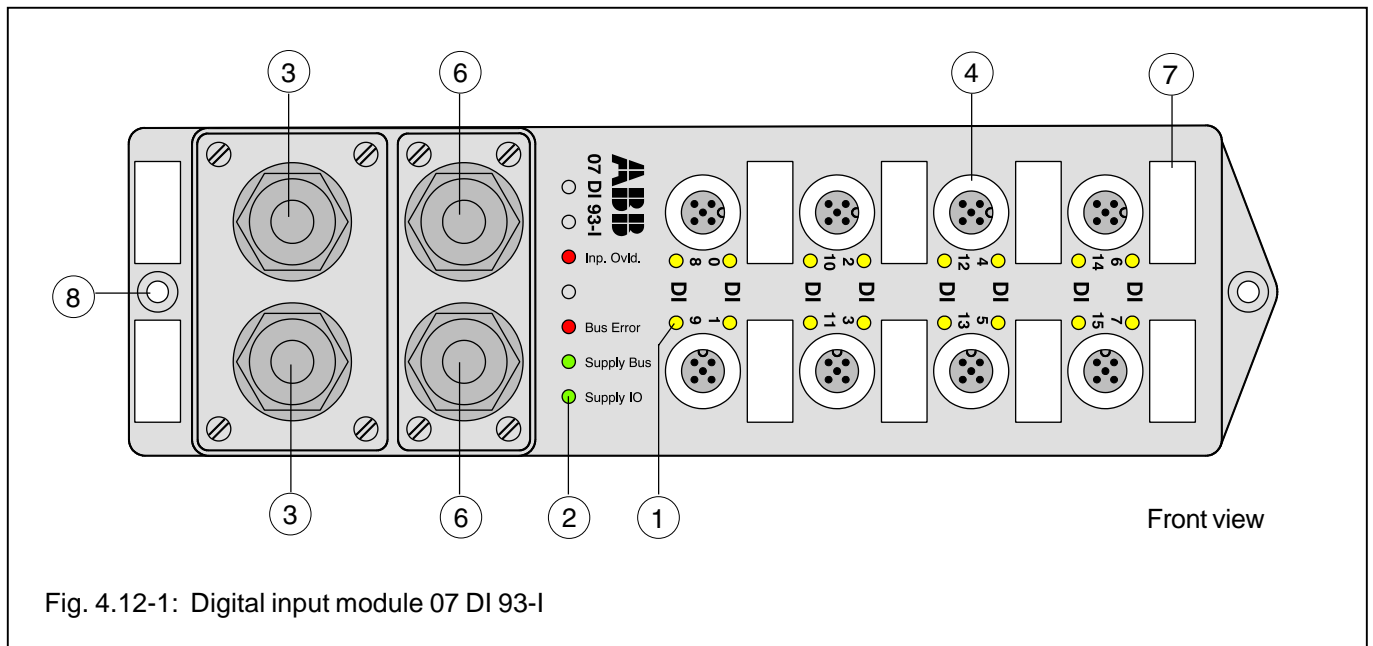

### Contents

Intended purpose .....	4.12-1
Displays and connections at the module housing .....	4.12-1
Electrical connection .....	4.12-1
Dimensioned drawing .....	4.12-3
Addressing .....	4.12-4
I/O configuration .....	4.12-4
Normal operation .....	4.12-4
Diagnosis and displays .....	4.12-5
Technical data .....	4.12-6

### Intended purpose

The digital input module 07 DI 93-I is a remote module on the CS31 system bus. It has 16 input channels with the following features:

- Housing and connection according to IP67 degree of protection.
- The CS31 bus line is looped through from module to module (one PG9 screwed conduit entry each for input and output).
- Each pair of inputs have their own connector and thus can be unplugged individually.
- The inputs
  - allow you to connect sensors with 2-pole and 3-pole technique (switching contacts, initiators etc.)
  - provide a short-circuit/overload-proof supply

voltage for the sensors, with can be loaded with max. 50 mA by each sensor

- have a rated signal current of approx. 8 mA each

The module is mounted with screws.

The CS31 system bus connection is electrically isolated from remaining module components.

The module offers diagnosis functions.

### Displays and connections at the module housing

- ① 16 yellow LEDs to indicate the signal status of the inputs
- ② LEDs "Bus Error", "Input Overload", "Supply Bus" and "Supply I/O" indicating operating conditions and errors
- ③ CS31 bus connector
- ④ 8 connectors for 16 inputs
- ⑥ 24 V DC power supply
- ⑦ Labelling fields
- ⑧ Bore holes for mounting

### Electrical connection

The following pages show all details necessary for the electrical connection.

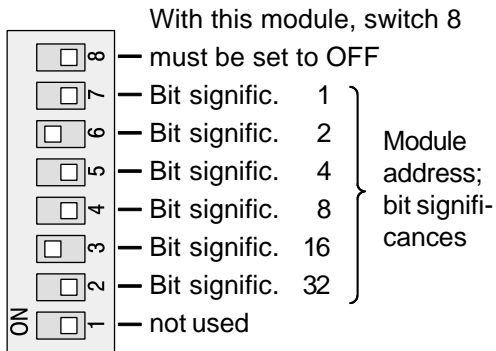

### Setting of the module address

The module address is calculated by the sum of significances of those switches which are set to ON.  
 Example: Switch 3 and 6 ON  
 Module address: 16 + 2 = 18

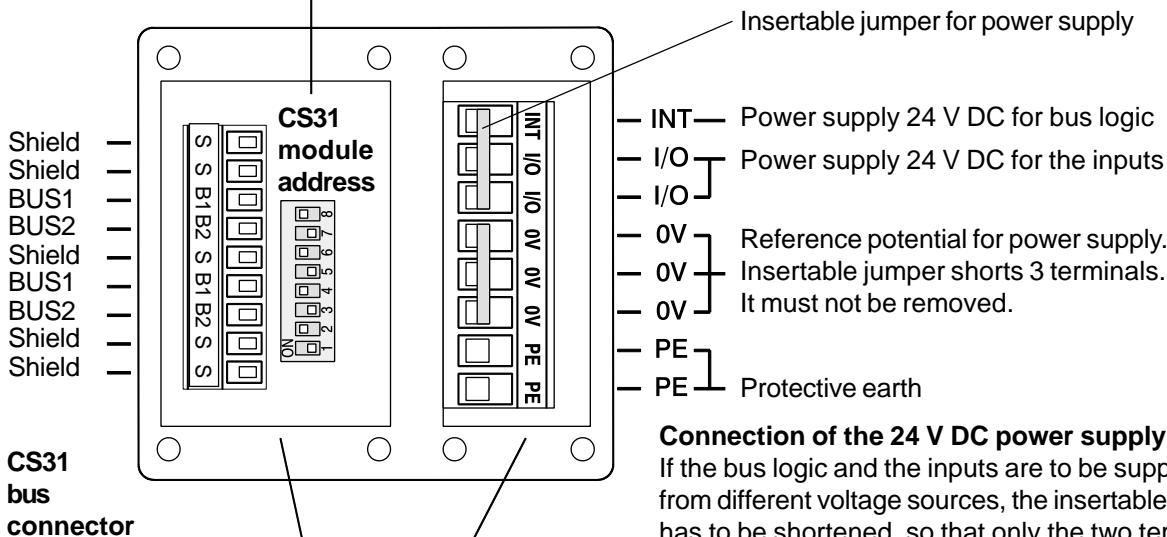

**Connection of the 24 V DC power supply:**  
 If the bus logic and the inputs are to be supplied from different voltage sources, the insertable jumper has to be shortened, so that only the two terminals I/O are short-circuited.

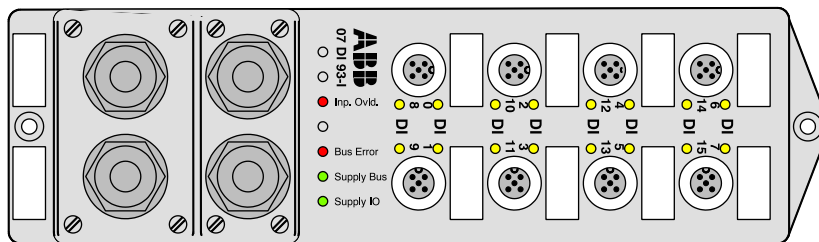

Front view

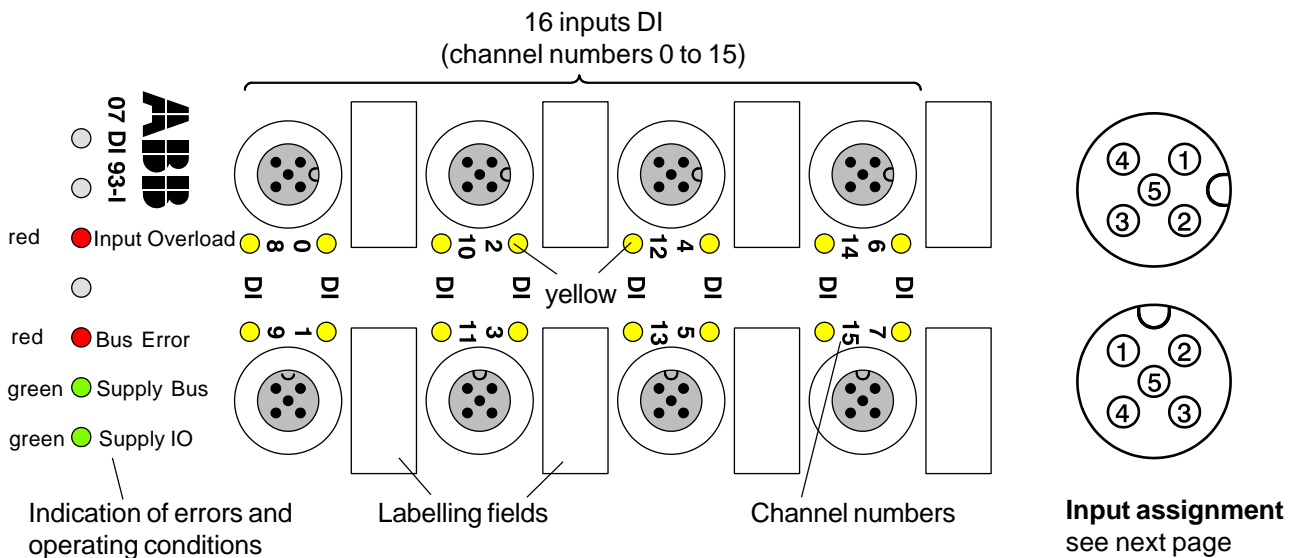
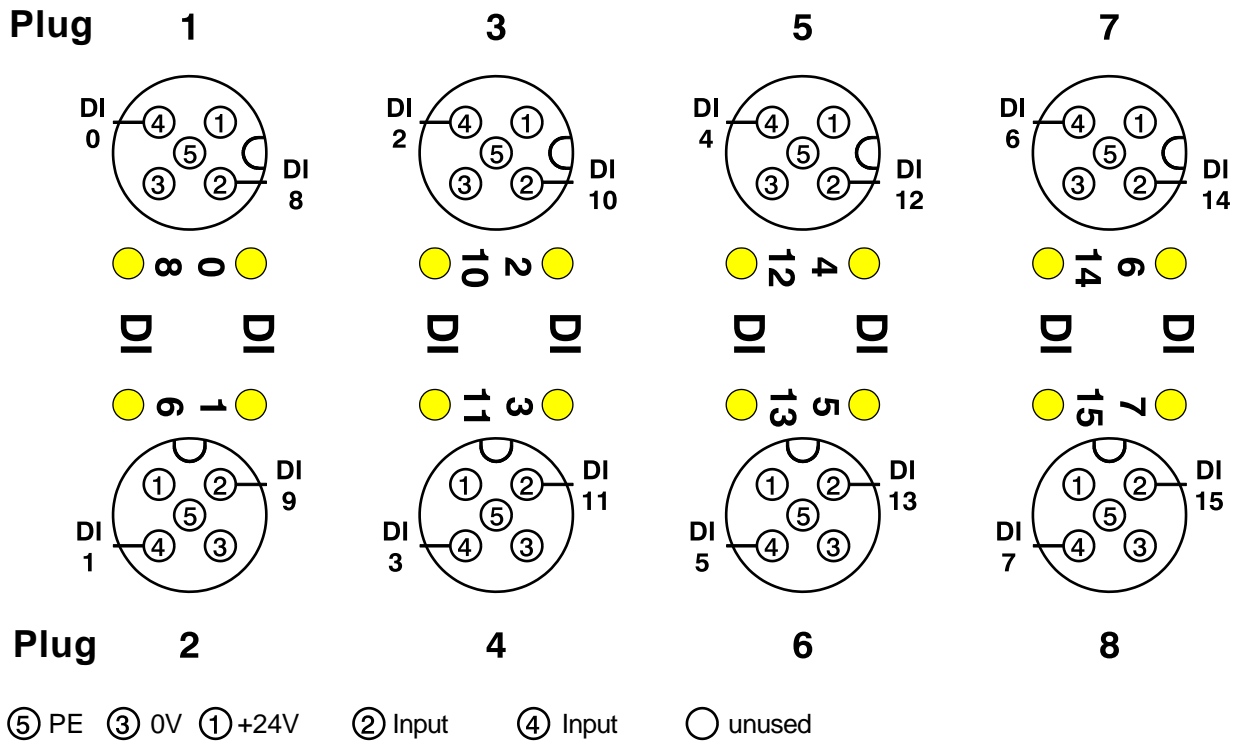
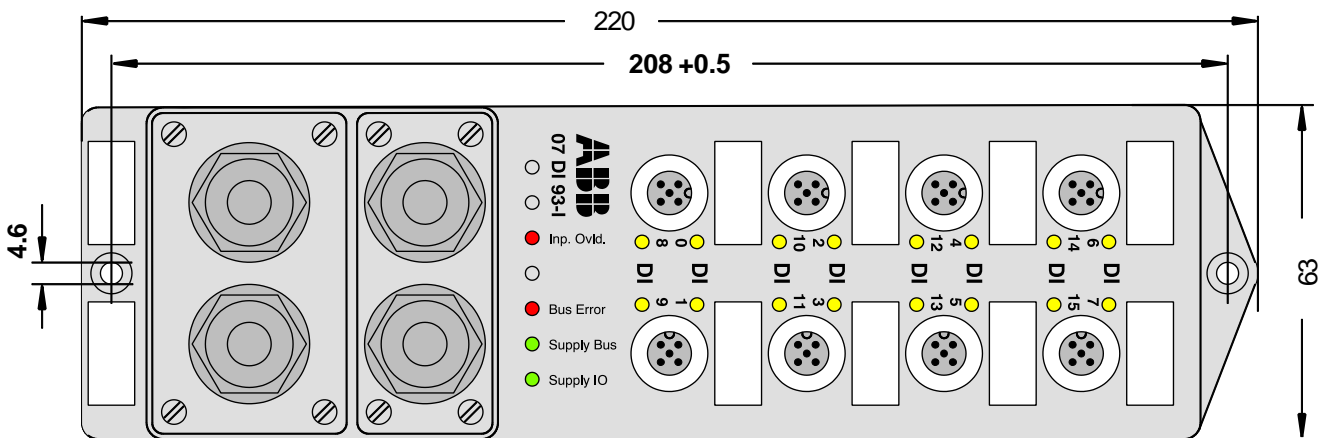

Fig. 4.12-2: Details for the electrical connection of the input module 07 DI 93-I



### 07 DI 93-I

Fig. 4.12-3: Detailed pin assignment of the inputs of the module 07 DI 93-I



#### Front view

The height is 70.5 mm

The dimensions for mounting with screws (assembly holes) are printed in **bold**.  
The height of the module is **70.5 mm**.

Fig. 4.12-4: Outline dimensions of the input module 07 DI 93-I

## Addressing

An address has to be set on each module, so that the central unit can access the inputs correctly.

**A detailed description concerning the item "Addressing" is contained in the chapters "Addressing" of the central units and couplers.**

The module address is set on the DIL switch located under the cover at the top side of the module.

Meaning of the address switches:

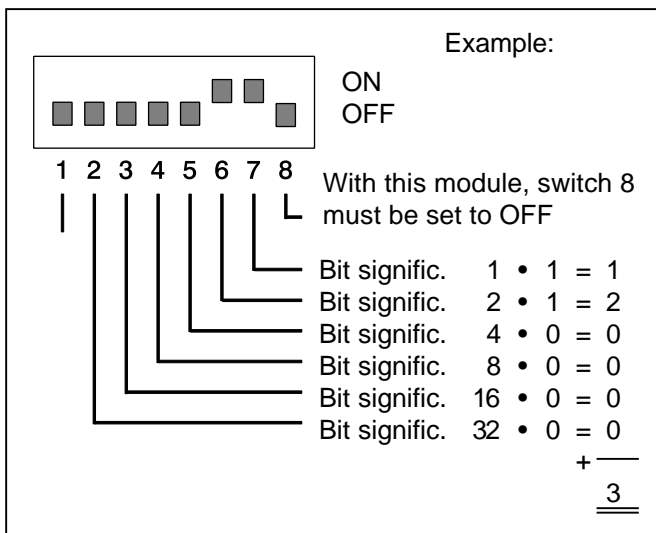
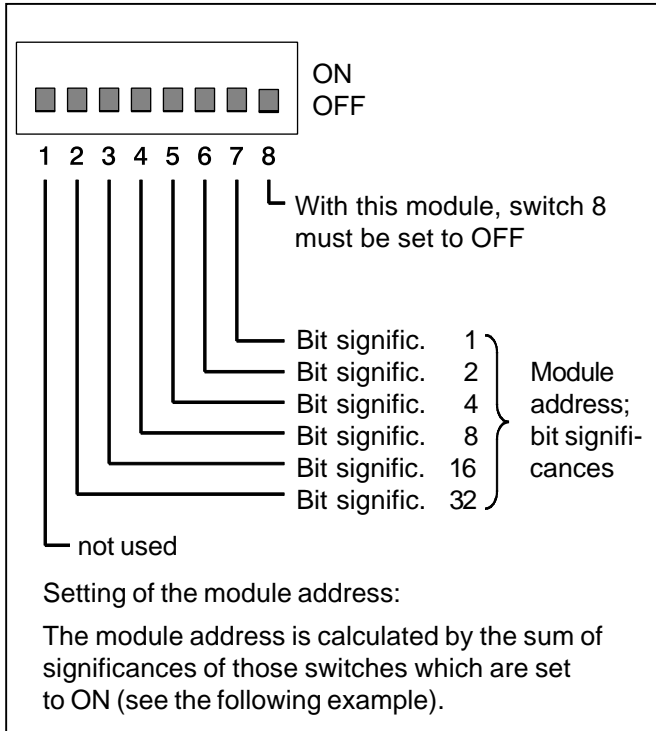

When using the central units 07 KR 91, 07 KT 9x, the possible module addresses range from

0...61.

In connection with the central units 07 KR 91 and 07 KT 9x as bus masters, the following address allocations are valid:

Central units 07 KR 91 / 07 KT 9x		
The DIL switch No. 8 is set to:		
	↓	
Chan.	OFF	
DI 0	E xx,00	With this module the DIL switch No. 8 must be set to OFF.
DI 1	E xx,01	
DI 2	E xx,02	
DI 3	E xx,03	
DI 4	E xx,04	
DI 5	E xx,05	
DI 6	E xx,06	
DI 7	E xx,07	
DI 8	E xx,08	
DI 9	E xx,09	
DI 10	E xx,10	
DI 11	E xx,11	
DI 12	E xx,12	
DI 13	E xx,13	
DI 14	E xx,14	
DI 15	E xx,15	
xx: Group number of the address, set on the DIL switch with the switches 2...7.		

The module uses 16 inputs on the CS31 system bus.

## I/O configuration

With this module, an I/O configuration is not necessary.

## Normal operation

- The module initializes itself after power ON. During initialization process all four LEDs ② are ON.
- After the initialization process, the two red LEDs ② go out again, if the bus is running correctly and the module does not detect any error. The green LEDs "Supply Bus" and "Supply I/O" light up.
- The 16 yellow LEDs ① indicate the signal status of the inputs and outputs.

## Diagnosis and displays

Diagnosis functions:

- Bus Error (on the CS31 system bus)
- Input Overload (overload or short-circuit at the power supply of the sensors)
- Supply Bus (power supply of the bus logic)
- Supply I/O (power supply for the inputs and outputs)

Diagnosis and error table:

Bus Error	Input Overload	Supply Bus	Supply I/O	LED flash.	LED ON	LED OFF	Explanation
<input type="checkbox"/>	<input type="checkbox"/>	<input type="checkbox"/>	<input type="checkbox"/>	<input checked="" type="checkbox"/>	<input type="checkbox"/>	<input type="checkbox"/>	The module is not connected at all, or the 24 V DC power supply is OFF.
<input type="checkbox"/>	<input type="checkbox"/>	<input checked="" type="checkbox"/>	<input checked="" type="checkbox"/>	<input type="checkbox"/>	<input type="checkbox"/>	<input type="checkbox"/>	Power is ON, the bus is running, no error.
<input type="checkbox"/>	<input checked="" type="checkbox"/>	<input checked="" type="checkbox"/>	<input checked="" type="checkbox"/>	<input type="checkbox"/>	<input type="checkbox"/>	<input type="checkbox"/>	Power is ON, there is a short-circuit/overload on at least one +24 V DC power supply connection of an input, the bus is running.
<input checked="" type="checkbox"/>	<input type="checkbox"/>	<input checked="" type="checkbox"/>	<input checked="" type="checkbox"/>	<input type="checkbox"/>	<input type="checkbox"/>	<input type="checkbox"/>	Power is ON, the bus does not run.
<input checked="" type="checkbox"/>	<input checked="" type="checkbox"/>	<input checked="" type="checkbox"/>	<input checked="" type="checkbox"/>	<input type="checkbox"/>	<input type="checkbox"/>	<input type="checkbox"/>	Power is ON, there is a short-circuit/overload on at least one +24 V DC power supply connection of an input, the bus does not run.
<input checked="" type="checkbox"/>	<input checked="" type="checkbox"/>	<input checked="" type="checkbox"/>	<input checked="" type="checkbox"/>	<input type="checkbox"/>	<input type="checkbox"/>	<input type="checkbox"/>	Initialization phase after power ON.

### Behaviour in case of short-circuit or overload at sensors:

The supply connections at the sensor input connectors are connected via a temperature-dependent resistor (PTC thermistor) to the + 24 V DC input of the screw-type ter-

minals. If an overload or a short-circuit occurs with a sensor, the PTC will work as an overload protection. A voltage monitoring circuitry generates an error message in case of undervoltage (the LED "Overload" lights up). The following figure demonstrates the function.

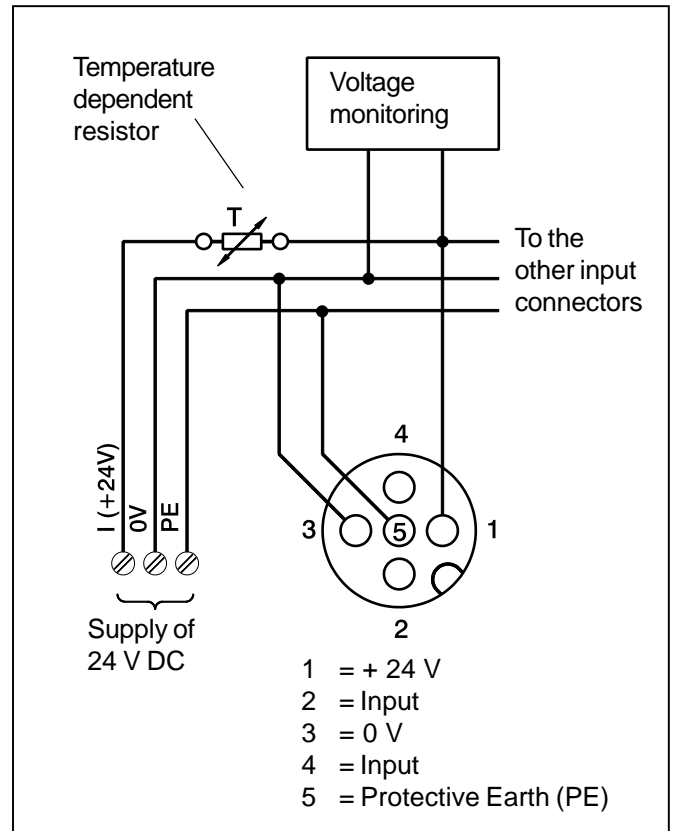

After the short-circuit or overload has been eliminated, the module can operate correctly again. The red LED "Input Overload" goes out.

### Error message to the master:

In case of a short-circuit or an overload, an error message is sent to the master, along with the error code No. 4. In each case, the channel No. 0 is given as faulty, independent of the really involved channel. The error message is kept up for a period of at least 5 seconds, even if the short-circuit or overload has been remedied in a shorter time.

For further information concerning diagnosis, see the descriptions of the central units and couplers used as bus masters.

## Technical Data 07 DI 93-I

In general, the technical system data listed under "System data and system configuration" in chapter 1 of volume 2 of the "Advant Controller 31" system description are valid. Additional data or data which are different from the system data are listed as follows.

### Connectors and terminals

Power supply 24 V DC	Screw-type terminals 1.5 mm <sup>2</sup> inside the housing, PG9 gland for cable
CS31bus line	Screw-type terminals 1.5 mm <sup>2</sup> inside the housing, PG9 gland for cable
16 inputs	8 x 5-pole M12 connectors (female) 2 inputs per connector

### Power supply

Rated supply voltage	24 V DC
Current consumption, without output loads	max. 80 mA
Conductor cross section	max. 1.5 mm <sup>2</sup> (with inserted jumper) max. 2.5 mm <sup>2</sup> (without inserted jumper)

### Inputs

Number of inputs per module	16
Signal level of the inputs	with signal 1 11 - 30 V with signal 0 0 - 5 V
Signal input current with signal 1	approx. 8 mA
Input signal delay	approx. 1 ms
Short-circuit protection for sensors	PTC, $I_K \geq 1.6 \text{ A}$

## Interfaces

Transmission standard between the central unit and input/output modules

EIA RS-485 (CS31 system bus)

Bus transmission time

387  $\mu$ s

## LED indicators

Input signals

1 yellow LED per channel

Bus Error

1 red LED

Input Overload (short-circuit or overload)

1 red LED (lights up, when there is an overload or a short-circuit at the supply voltage for the sensors)

Supply Bus (power supply for bus logic)

1 green LED (lights up, when the supply voltage is  $\geq 18$  V)

Supply IO (power supply for inputs/outputs)

1 green LED (lights up, when the supply voltage is  $\geq 18$  V)

## Mechanical data

Degree of protection according to DIN 40040, IEC 529

IP 67

Dimensions (length x width x height)

220 x 63.0 x 70.5 mm

Mounting dimension

208 mm (+0.5 mm)

Weight

approx. 470 g

## Ordering data

Order No.

Input/output module 07 DI 93-I

GJV3 0756 13 R0202

Accessories:

5-pole M12 plug, male, "straight"

GJV3 0756 17 R0001

5-pole M12 plug, male, "bended"

GJV3 0756 18 R0001

4-pole M12 plug, male, "straight"

GJV3 0756 24 R0001

M12 filler plug (4 plugs are provided with the module)

GJV3 0756 19 R0001

## Note:

In order to meet the degree of protection IP67, suitable cables with certain diameters must be used at the cable glands (bus, I/O connectors, supply voltage): cable diameters for I/O 4.5 mm to 6.5 mm, for supply voltage and CS31 system bus 5 mm to 10 mm. The electrical specifications for the bus cables can be found under the Advant Controller 31 system data.

Unused cable glands have to be sealed with filler plugs.





## 4.13 Digital Output Module 07 DO 93-I

8 output channels 24 V DC/2A, degree of protection IP67, electrically isolated CS31 system bus connection

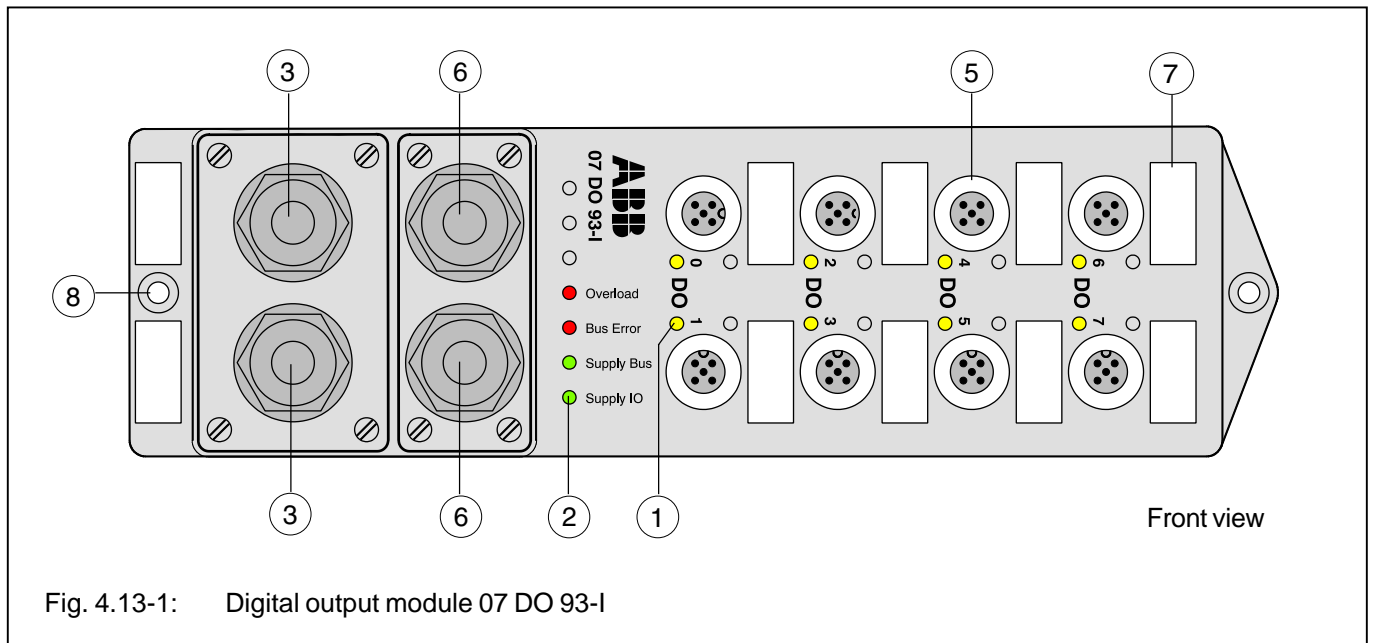

### Contents

Intended purpose .....	4.13-1
Displays and connections at the module housing .....	4.13-1
Electrical connection .....	4.13-1
Dimensioned drawing .....	4.13-3
Addressing .....	4.13-4
I/O configuration .....	4.13-4
Normal operation .....	4.13-4
Diagnosis and displays .....	4.13-5
Technical data .....	4.13-6

### Intended purpose

The digital output module 07 DO 93-I is a remote module on the CS31 system bus. It has 8 output channels with the following features:

- Housing and connection according to IP67 degree of protection.
- The CS31 bus line is looped through from module to module (one PG9 screwed conduit entry each for input and output).
- Each output has its own connector and thus can be unplugged individually.
- The outputs
  - employ semiconductors,
  - have a rated load capability of 2 A and
  - are overload and short-circuit proof.

The module is mounted with screws.

The CS31 system bus connection is electrically isolated from remaining module components.

The module offers diagnosis functions.

### Displays and connections at the module housing

- ① 8 yellow LEDs to indicate the signal status of the outputs
- ② LEDs "Bus Error", "Overload", "Supply Bus" and "Supply I/O" indicating the operating conditions and errors
- ③ CS31 bus connector
- ⑤ 8 connectors for 8 outputs
- ⑥ 24 V DC power supply
- ⑦ Labelling fields
- ⑧ Bore holes for mounting

### Electrical connection

The following pages show all details necessary for the electrical connection.

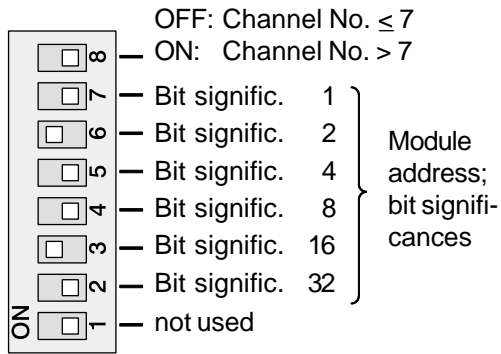

### Setting of the module address

The module address is calculated by the sum of significances of those switches which are set to ON.  
Example: Switches 3 and 6 ON  
Module address: 16 + 2 = 18

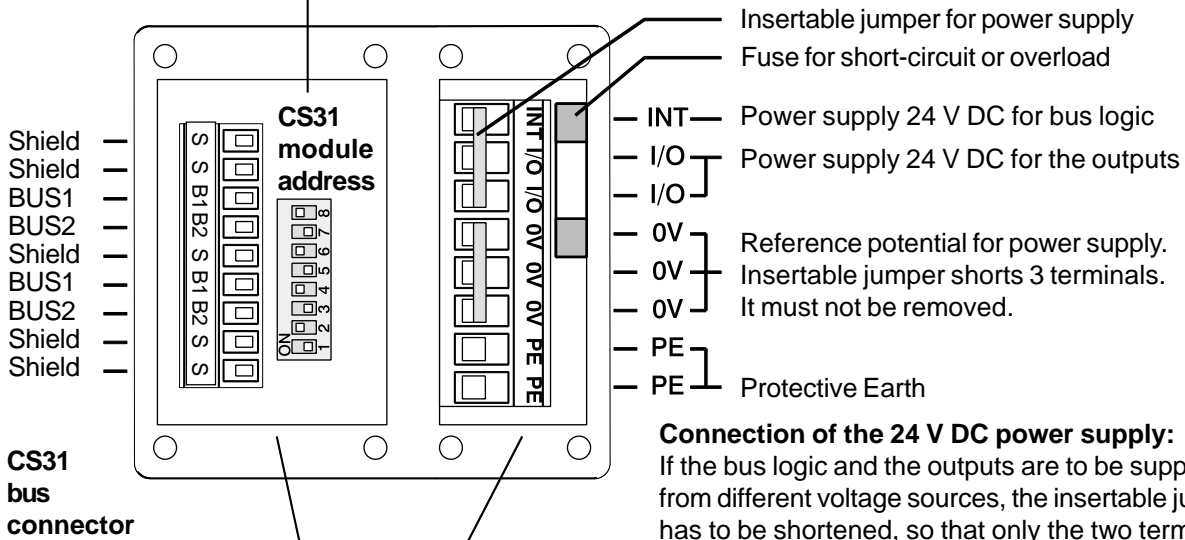

### Connection of the 24 V DC power supply:

If the bus logic and the outputs are to be supplied from different voltage sources, the insertable jumper has to be shortened, so that only the two terminals I/O are short-circuited.

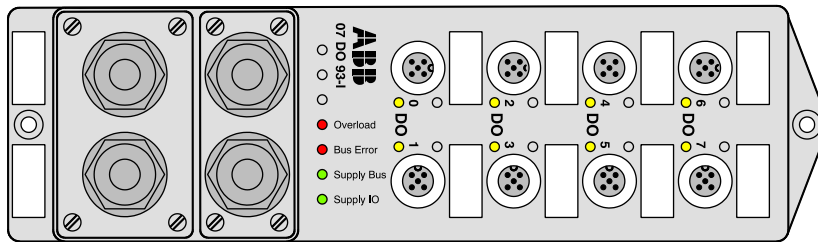

Front view

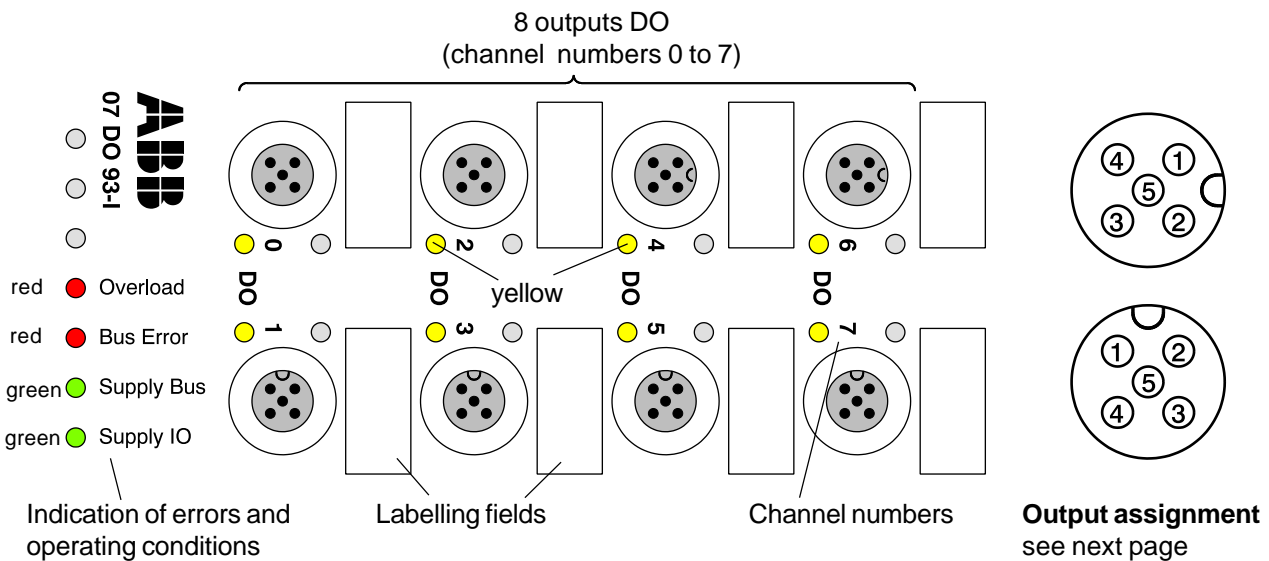
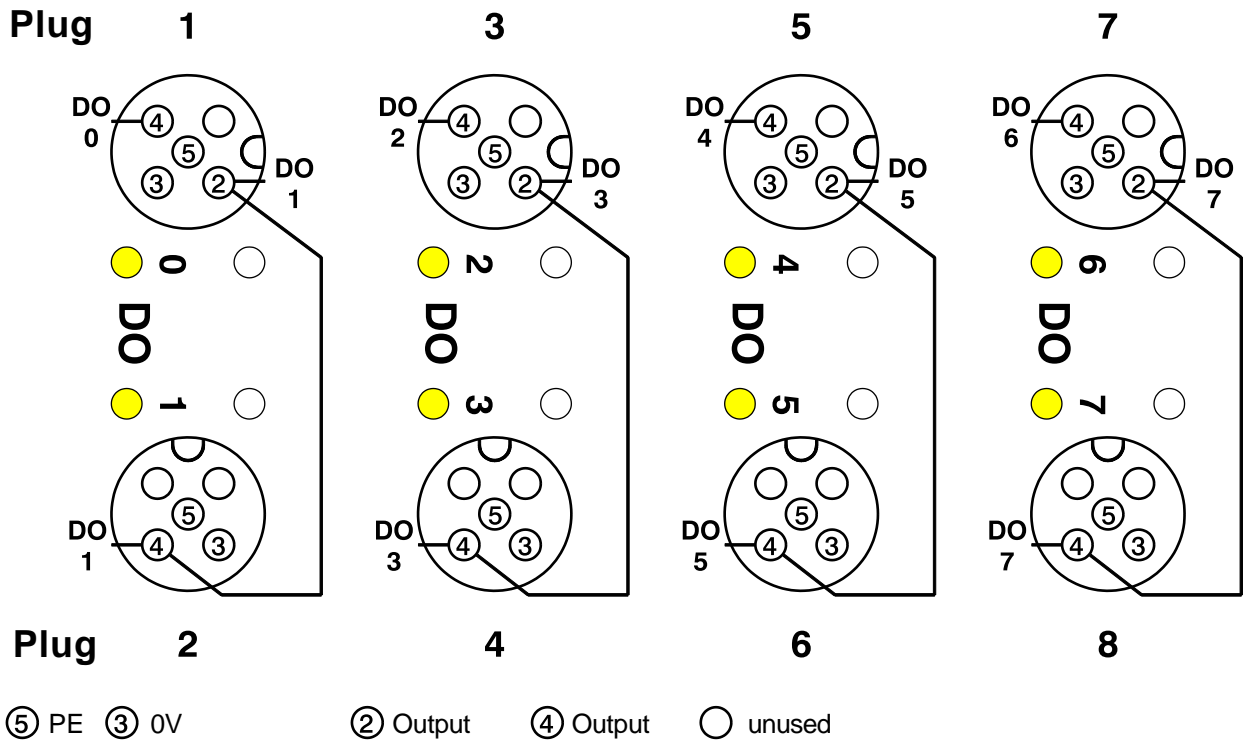
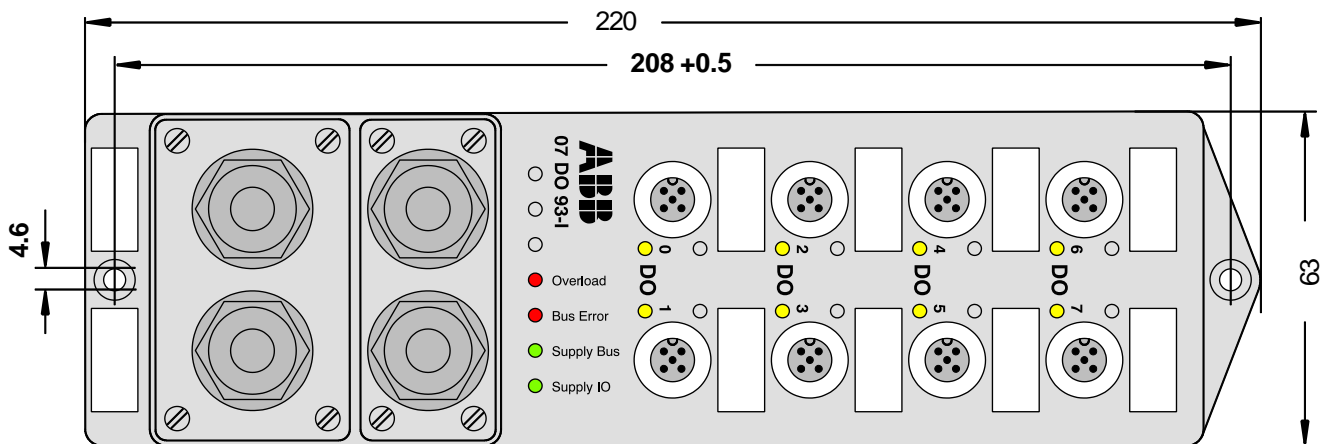

Fig. 4.13-2: Details for the electrical connection of the output module 07 DO 93-I



### 07 DO 93-I

Fig. 4.13-3: Detailed pin assignment of the outputs of the module 07 DO 93-I



**Front view**

The height is 70.5 mm

The dimensions for mounting with screws (assembly holes) are printed in **bold**.  
 The height of the module is **70.5 mm**.

Fig. 4.13-4: Outline dimensions of the output module 07 DO 93-I

## Addressing

An address has to be set on each module, so that the central unit can access the outputs correctly.

**A detailed description concerning the item "Addressing" is contained in the chapters "Addressing" of the central units and couplers.**

The module address is set on the DIL switch located under the cover at the top side of the module.

Meaning of the address switches:

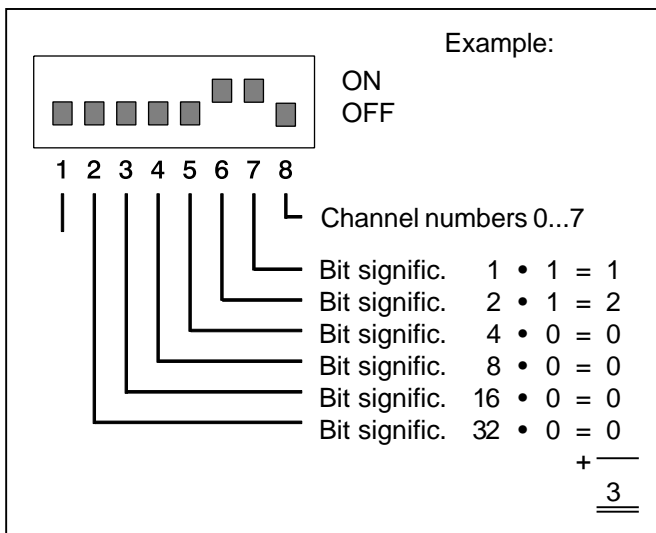
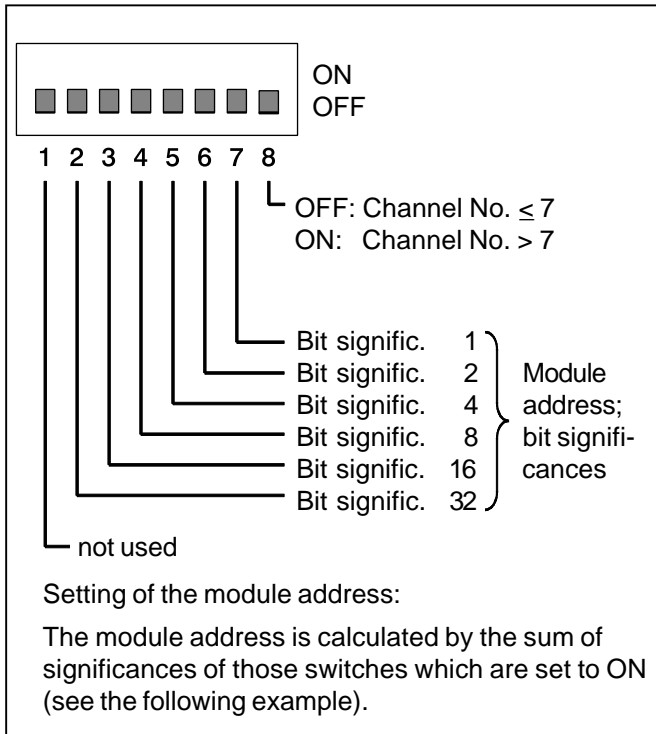

When using the central units 07 KR 91, 07 KT 9x, the possible module addresses range from

0...61.

In connection with the central units 07 KR 91 and 07 KT 9x as bus masters, the following address allocations are valid:

Central units 07 KR 91 / 07 KT 9x			
The DIL switch No. 8 is set to:			
Chan.	OFF	Chan.	ON
DO 0	A xx,00	DO 0	A xx,08
DO 1	A xx,01	DO 1	A xx,09
DO 2	A xx,02	DO 2	A xx,10
DO 3	A xx,03	DO 3	A xx,11
DO 4	A xx,04	DO 4	A xx,12
DO 5	A xx,05	DO 5	A xx,13
DO 6	A xx,06	DO 6	A xx,14
DO 7	A xx,07	DO 7	A xx,15

xx: Group number of the address, set on the DIL switch with the switches 2...7.

The module uses 8 outputs on the CS31 system bus.

## I/O configuration

With this module, an I/O configuration is not necessary.

## Normal operation

- The module initializes itself after power ON. During initialization process all four LEDs ② are ON.
- After the initialization process, the two red LEDs ② go out again, if the bus is running correctly and the module does not detect any error. The green LEDs "Supply Bus" and "Supply I/O" light up.
- The 8 yellow LEDs ① indicate the signal status of the outputs.

## Diagnosis and displays

Diagnosis functions:

- Bus Error (on the CS31 system bus)
- Overload (overload or short-circuit at an output)
- Supply Bus (power supply of the bus logic)
- Supply I/O (power supply for the inputs and outputs)

Diagnosis and error table:

Bus Error	Overload	Supply Bus	Supply I/O	LED flash.	LED ON	LED OFF	Explanation
<input type="checkbox"/>	<input type="checkbox"/>	<input type="checkbox"/>	<input type="checkbox"/>	<input checked="" type="checkbox"/>	<input type="checkbox"/>	<input type="checkbox"/>	The module is not connected at all, or the 24 V DC power supply is OFF.
<input type="checkbox"/>	<input type="checkbox"/>	<input checked="" type="checkbox"/>	<input checked="" type="checkbox"/>	<input type="checkbox"/>	<input type="checkbox"/>	<input type="checkbox"/>	Power is ON, the bus is running, no error.
<input type="checkbox"/>	<input checked="" type="checkbox"/>	<input checked="" type="checkbox"/>	<input checked="" type="checkbox"/>	<input type="checkbox"/>	<input type="checkbox"/>	<input type="checkbox"/>	Power is ON, there is a short-circuit/overload on at least one output, the bus is running.
<input checked="" type="checkbox"/>	<input type="checkbox"/>	<input checked="" type="checkbox"/>	<input checked="" type="checkbox"/>	<input type="checkbox"/>	<input type="checkbox"/>	<input type="checkbox"/>	Power is ON, the bus does not run.
<input checked="" type="checkbox"/>	<input checked="" type="checkbox"/>	<input checked="" type="checkbox"/>	<input checked="" type="checkbox"/>	<input type="checkbox"/>	<input type="checkbox"/>	<input type="checkbox"/>	Power in ON, there is a short-circuit/overload on at least one output, the bus does not run.
<input checked="" type="checkbox"/>	<input checked="" type="checkbox"/>	<input checked="" type="checkbox"/>	<input checked="" type="checkbox"/>	<input type="checkbox"/>	<input type="checkbox"/>	<input type="checkbox"/>	Initialization phase after power ON.

## Behaviour in case of short-circuit or overload at outputs:

If a short-circuit or an overload has occurred on an output channel, the involved channel will be switched off as a reaction on a high temperature of the switching transistor. In certain intervals, the module then tries to switch on the channel again. Before every switching-on trial, the signal at all channels will be interrupted for a period of approx. 20 µs. This is also valid for those channels which are not involved in the overload or short-circuit event.

After the short-circuit or overload has been eliminated, the involved channel can operate immediately again. The red LED "Overload" goes out.

## Error message to the master:

In case of a short-circuit or an overload, an error message is sent to the master, along with the error code No. 4. In each case, the channel No. 0 is given as faulty, independent of the really involved channel. The error message is kept up for a period of at least 5 seconds, even if the short-circuit or overload has been remedied in a shorter time.

For further information concerning diagnosis, see the descriptions of the central units and couplers used as bus masters.

## Technical Data 07 DO 93-I

In general, the technical system data listed under "System data and system configuration" in chapter 1 of volume 2 of the "Advant Controller 31" system description are valid. Additional data or data which are different from the system data are listed as follows.

### Connectors and terminals

Power supply 24 V DC	Screw-type terminals 1.5 mm <sup>2</sup> inside the housing, PG9 gland for cable
CS31 bus line	Screw-type terminals 1.5 mm <sup>2</sup> inside the housing, PG9 gland for cable
8 outputs	8 x 5-pole M12 connectors (female)

### Power supply

Rated supply voltage	24 V DC
Current consumption, without output loads	max. 80 mA
Supply current for the outputs	max. 10 A
Conductor cross section	max. 1.5 mm <sup>2</sup> (with inserted jumper) max. 2.5 mm <sup>2</sup> (without inserted jumper)
Internal fuse (under the cover)	16 A, slow-acting, 5 x 20 mm

### Outputs

Number of outputs per module	8 (overload and short-circuit proof, electrically not isolated)
Signal level of the outputs at signal 1	like L+, max. internal voltage loss 0.1 V
Output load capability	
max. current per output	2 A, 100 % ED
lamp load per output	max. 50 W
total switching current (all outputs together)	max. 10 A
Switching frequency	
with inductive load	max. 1 Hz
with resistive load	max. 100 Hz
Short-circuit and overload protection	electronically
Short-circuit indication	yes, with a red LED
Limitation of output voltage, if an inductive load is switched off	by an integrated suppressor diode

## Interfaces

Transmission standard between the central unit and input/output modules	EIA RS-485 (CS31 system bus)
Bus transmission time	323 $\mu$ s

## LED indicators

Output signals	1 yellow LED per channel
Bus Error	1 red LED
Overload (short-circuit or overload)	1 red LED (lights up when at least one output is short-circuited or overloaded)
Supply Bus (power supply for bus logic)	1 green LED (lights up when the supply voltage is $\geq 18$ V)
Supply IO (power supply for inputs/outputs)	1 green LED (lights up when the supply voltage is $\geq 18$ V)

## Mechanical data

Degree of protection according to DIN 40040, IEC 529	IP 67
Dimensions (length x width x height)	220 x 63.0 x 70.5 mm
Mounting dimension	208 mm (+0.5 mm)
Weight	approx. 470 g

## Ordering data

Input/output module 07 DO 93-I	Order No. GJV3 0756 11 R0202
--------------------------------	---------------------------------

### Accessories:

5-pole M12 plug, male, "straight"	GJV3 0756 17 R0001
5-pole M12 plug, male, "bended"	GJV3 0756 18 R0001
4-pole M12 double plug, male, "straight"	GJV3 0756 24 R0001
M12 filler plug (4 plugs are provided with the module)	GJV3 0756 19 R0001

### Note:

In order to meet the degree of protection IP67, suitable cables with certain diameters must be used at the cable glands (bus, I/O connectors, supply voltage): cable diameters for I/O 4.5 mm to 6.5 mm, for supply voltage and CS31 system bus 5 mm to 10 mm. The electrical specifications for the bus cables can be found under the Advant Controller 31 system data.

Unused cable glands have to be sealed with filler plugs.





## 4.14 Digital Input/Output Module 07 DK 93-I

8 input channels 24 V DC, 4 output channels 24 V DC/2A, **degree of protection IP67**, electrically isolated CS31 system bus connection

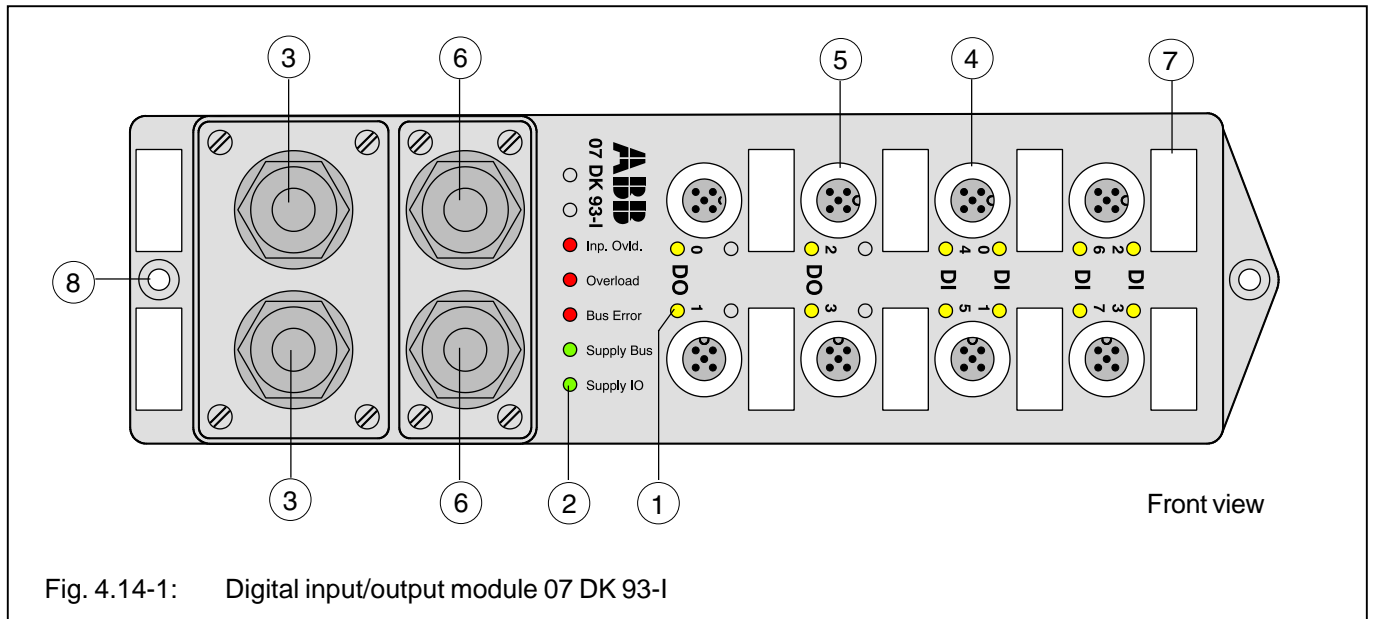

### Contents

Intended purpose .....	4.14-1
Displays and connections at the module housing .....	4.14-1
Electrical connection .....	4.14-1
Dimensioned drawing .....	4.14-3
Addressing .....	4.14-4
I/O configuration .....	4.14-4
Normal operation .....	4.14-4
Diagnosis and displays .....	4.14-5
Technical data .....	4.14-6

### Intended purpose

The digital input/output module 07 DK 93-I is a remote module on the CS31 system bus. It has 8 input and 4 output channels with the following features:

- Housing and connection according to IP67 degree of protection.
- The CS31 bus line is looped through from module to module (one PG9 screwed conduit entry each for input and output).
- Each output and each pair of inputs have their own connector and thus can be unplugged individually.
- The inputs
  - allow you to connect sensors with 2-pole and 3-pole technique (switching contacts, initiators etc.)
  - provide a short-circuit/overload-proof supply voltage for the sensors, which can be loaded with max. 100 mA per channel
  - have a rated signal current of approx. 8 mA each

- The outputs
  - employ semiconductors,
  - have a rated load capability of 2 A and
  - are overload and short-circuit proof.

The module is mounted with screws.

The CS31 system bus connection is electrically isolated from remaining module components.

The module offers diagnosis functions.

### Displays and connections at the module housing

- ① 12 yellow LEDs to indicate the signal status of the inputs and outputs
- ② LEDs "Bus Error", "Overload", "Input Overload", "Supply Bus" and "Supply I/O" indicating the operating conditions and errors
- ③ CS31 bus connector
- ④ 4 connectors for 8 inputs
- ⑤ 4 connectors for 4 outputs
- ⑥ 24 V DC power supply
- ⑦ Labelling fields
- ⑧ Bore holes for mounting

### Electrical connection

The following pages show all details necessary for the electrical connection.

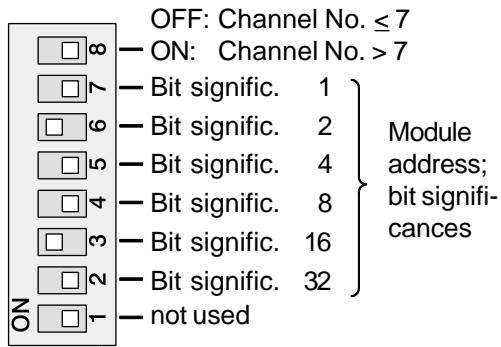

### Setting of the module address

The module address is calculated by the sum of significances of those switches which are set to ON.  
Example: Switch 3 and 6 ON  
Module address: 16 + 2 = 18

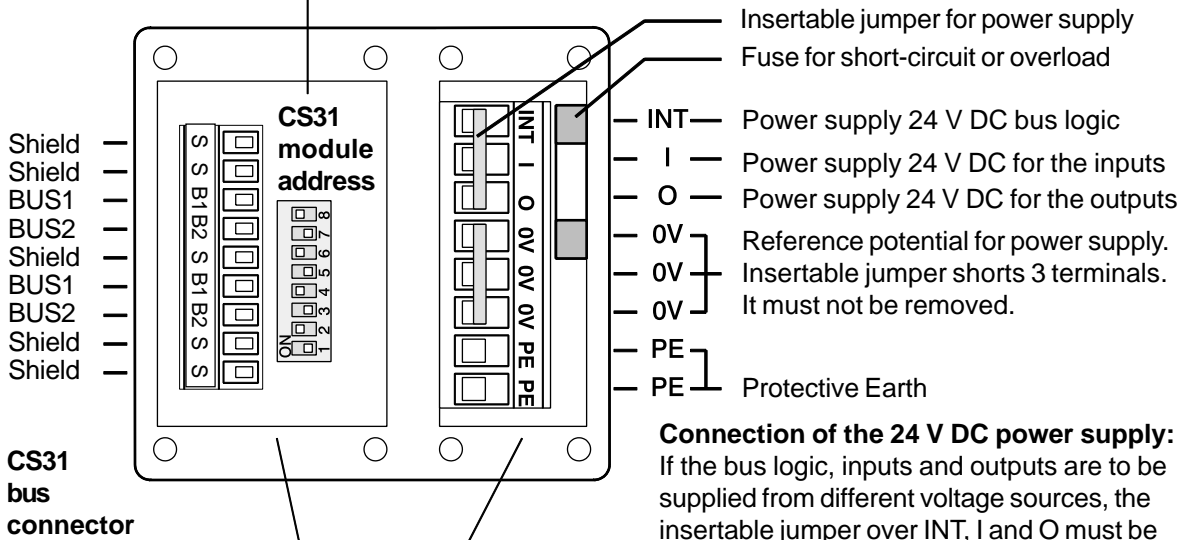

### Connection of the 24 V DC power supply:

If the bus logic, inputs and outputs are to be supplied from different voltage sources, the insertable jumper over INT, I and O must be removed.

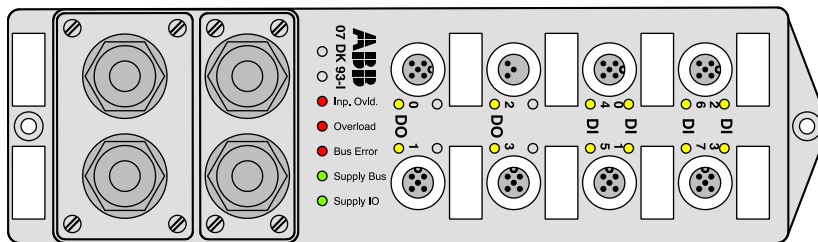

Front view

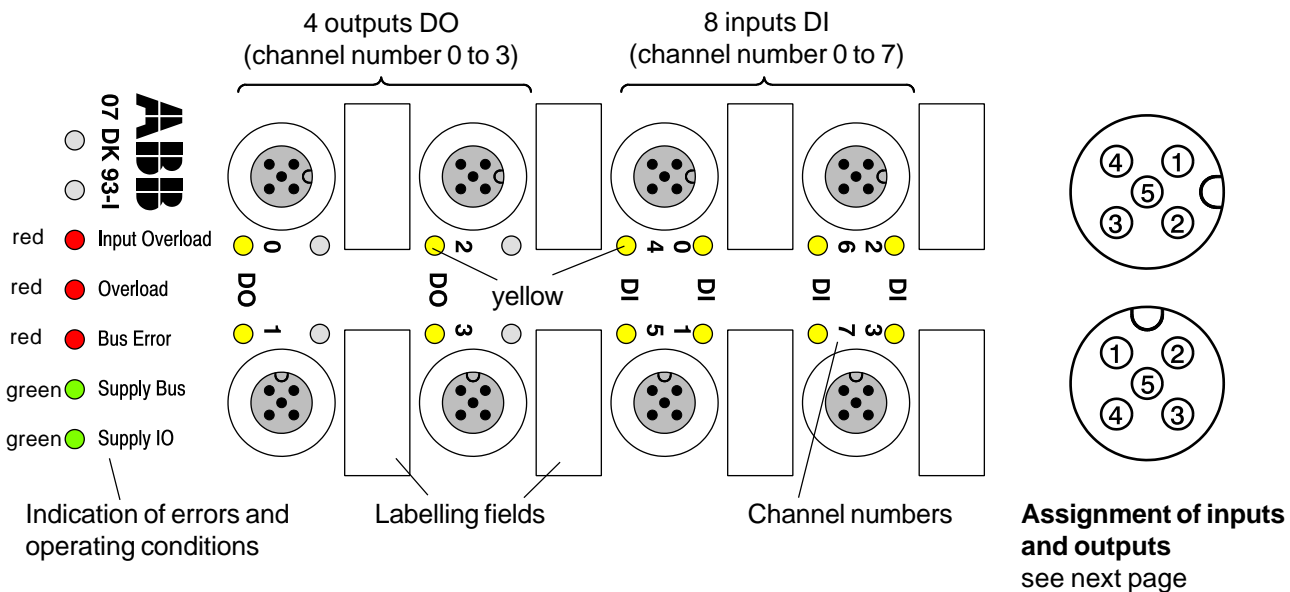
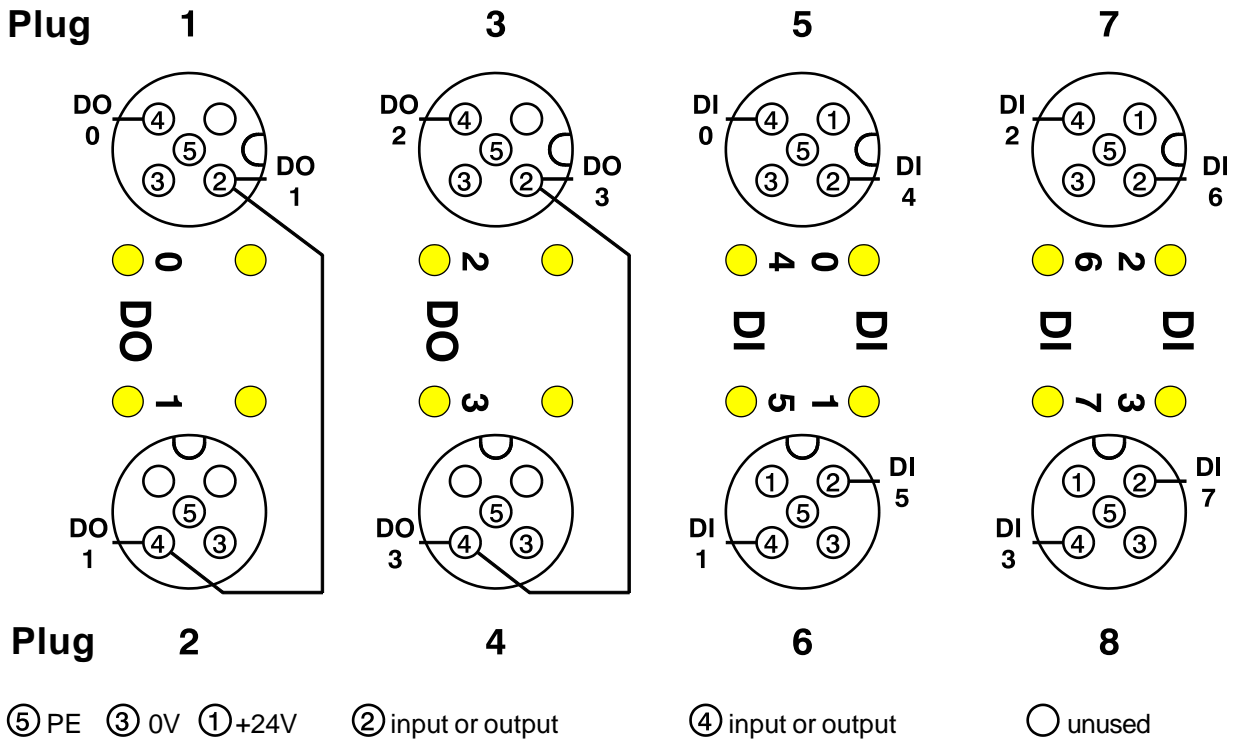
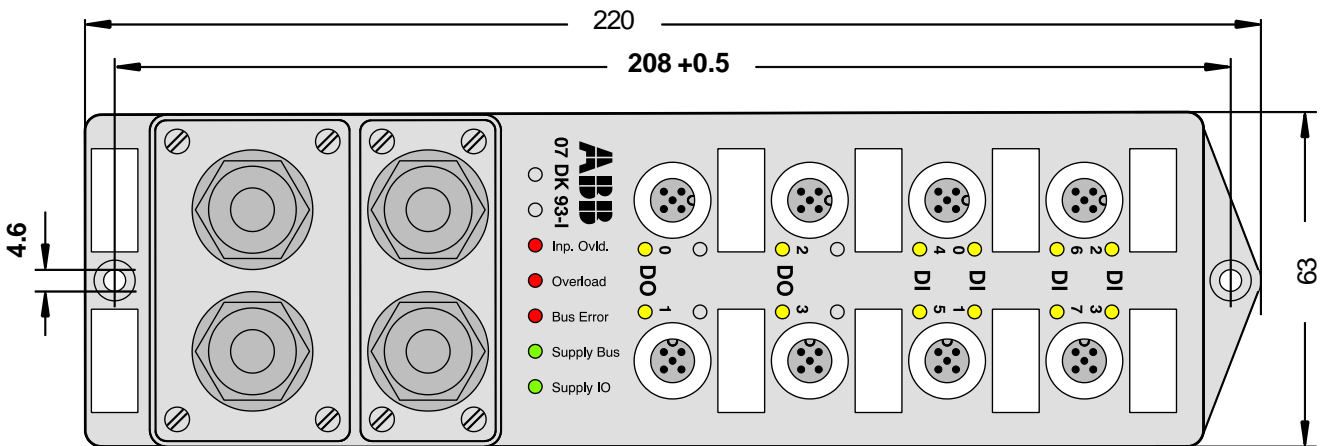

Fig. 4.14-2: Details for the connection of the input/output module 07 DK 93-I



### 07 DK 93-I

Fig. 4.14-3: Detailed pin assignment of the inputs and outputs of the module 07 DK 93-I



The dimensions for mounting with screws (assembly holes) are printed in **bold**.  
 The height of the module is **70.5 mm**.

Fig. 4.14-4: Outline dimensions of the input/output module 07 DK 93-I

## Addressing

An address has to be set on each module, so that the central unit can access the inputs and outputs correctly.

**A detailed description concerning the item "Addressing" is contained in the chapters "Addressing" of the central units and couplers.**

The module address is set on the DIL switch located under the cover at the top side of the module.

Meaning of the address switches:

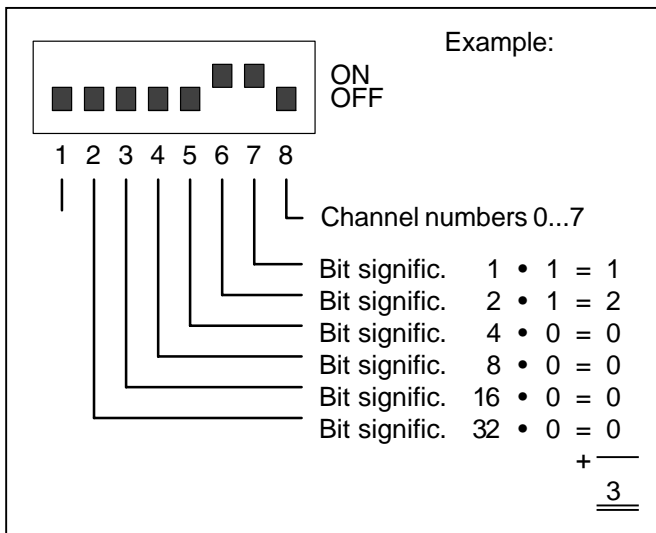
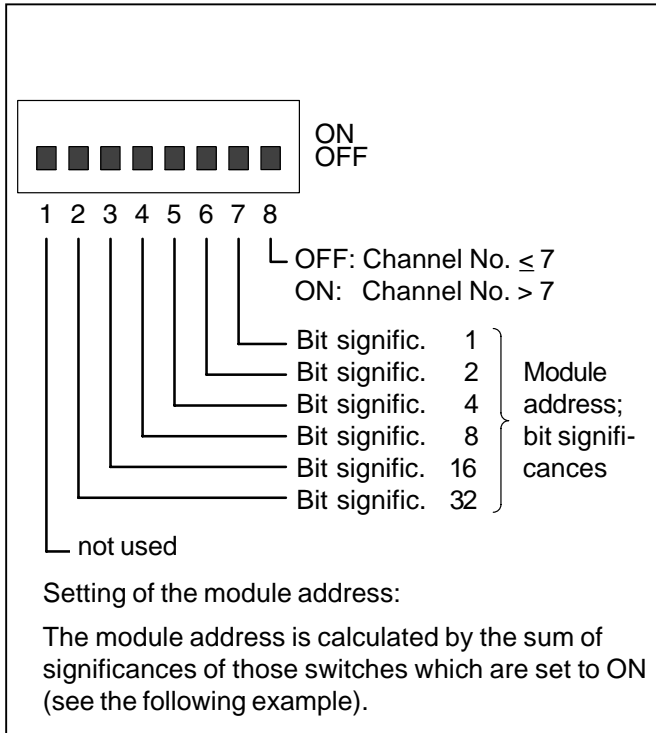

When using the central units 07 KR 91, 07 KT 9x, the possible module addresses range from 0...61.

In connection with the central units 07 KR 91 and 07 KT 9x as bus masters, the following address allocations are valid:

Central units 07 KR 91 / 07 KT 9x

The DIL switch No. 8 is set to:

Chan.	OFF	Chan.	ON
DI 0	E xx,00	DI 0	E xx,08
DI 1	E xx,01	DI 1	E xx,09
DI 2	E xx,02	DI 2	E xx,10
DI 3	E xx,03	DI 3	E xx,11
DI 4	E xx,04	DI 4	E xx,12
DI 5	E xx,05	DI 5	E xx,13
DI 6	E xx,06	DI 6	E xx,14
DI 7	E xx,07	DI 7	E xx,15
DO 0	A xx,00	DO 0	A xx,08
DO 1	A xx,01	DO 1	A xx,09
DO 2	A xx,02	DO 2	A xx,10
DO 3	A xx,03	DO 3	A xx,11

xx: Group number of the address, set on the DIL switch with switches 2...7.

The module uses 8 inputs and 8 outputs on the CS31 system bus.

## I/O configuration

With this module, an I/O configuration is not necessary.

## Normal operation

- The module initializes itself after power ON. During initialization process all five LEDs ② are ON.
- After the initialization process, the three red LEDs ② go out again, if the bus is running correctly and the module does not detect any error. The green LEDs "Supply Bus" and "Supply I/O" light up.
- The 12 yellow LEDs ① indicate the signal status of the inputs and outputs.

## Diagnosis and displays

Diagnosis functions:

- Bus Error (on the CS31 system bus)
- Overload (overload or short-circuit at an output)
- Input Overload (overload or short-circuit at the power supply of the sensors)
- Supply Bus (power supply of the bus logic)
- Supply I/O (power supply for the inputs and outputs)

Diagnosis and error table:

Bus Error	Overload	Input Overload	Supply Bus	Supply I/O	LED flash. / LED ON / LED OFF	Explanation
<input type="checkbox"/>	<input type="checkbox"/>	<input type="checkbox"/>	<input type="checkbox"/>	<input type="checkbox"/>	LED OFF	The module is not connected at all, or the 24 V DC power supply is OFF.
<input type="checkbox"/>	<input type="checkbox"/>	<input type="checkbox"/>	<input checked="" type="checkbox"/>	<input checked="" type="checkbox"/>	LED ON	Power is ON, the bus is running, no error.
<input type="checkbox"/>	<input checked="" type="checkbox"/>	<input type="checkbox"/>	<input checked="" type="checkbox"/>	<input checked="" type="checkbox"/>	LED flash.	Power is ON, there is a short-circuit/overload on at least one output, the bus is running.
<input type="checkbox"/>	<input type="checkbox"/>	<input checked="" type="checkbox"/>	<input checked="" type="checkbox"/>	<input checked="" type="checkbox"/>	LED flash.	Power is ON, there is a short-circuit/overload on at least one +24 V DC power supply connection of an input, the bus is running.
<input checked="" type="checkbox"/>	<input type="checkbox"/>	<input type="checkbox"/>	<input checked="" type="checkbox"/>	<input checked="" type="checkbox"/>	LED OFF	Power is ON, the bus does not run.
<input checked="" type="checkbox"/>	<input checked="" type="checkbox"/>	<input type="checkbox"/>	<input checked="" type="checkbox"/>	<input checked="" type="checkbox"/>	LED flash.	Power is ON, there is a short-circuit/overload on at least one output, the bus does not run.
<input checked="" type="checkbox"/>	<input checked="" type="checkbox"/>	<input checked="" type="checkbox"/>	<input checked="" type="checkbox"/>	<input checked="" type="checkbox"/>	LED ON	Initialization phase after power ON.

### Behaviour in case of short-circuit or overload at sensors:

The supply connections at the sensor input connectors are connected via a temperature-dependent resistor (PTC thermistor) to the +24 V DC input of the screw-type terminals. If an overload or a short-circuit occurs with a sensor, the PTC will work as an overload protection. A voltage monitoring circuitry generates an error message in case of undervoltage (the LED "Input Overload" lights up). The following figure demonstrates the function.

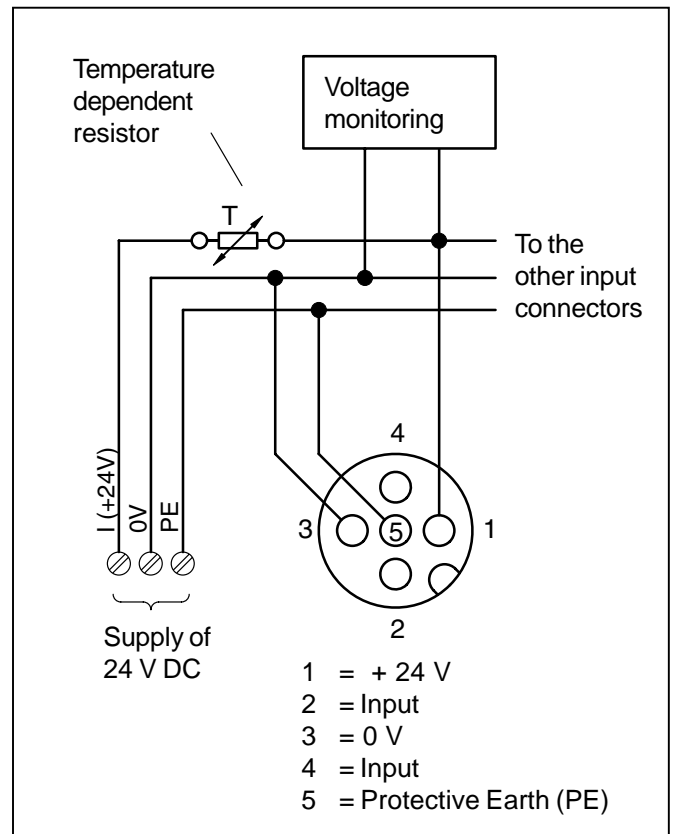

After the short-circuit or overload has been eliminated, the module can operate correctly again. The red LED "Input Overload" goes out.

### Behaviour in case of short-circuit or overload at outputs:

If a short-circuit or an overload has occurred on an output channel, the involved channel will be switched off as a reaction on a high temperature of the switching transistor. In certain intervals, the module then tries to switch on the channel again. Before every switching-on trial, the signal at all channels will be interrupted for a period of approx. 20  $\mu$ s. This is also valid for those channels which are not involved in the overload or short-circuit event.

After the short-circuit or overload has been eliminated, the involved channel can operate immediately again. The red LED "Overload" goes out.

### Error message to the master:

In case of a short-circuit or an overload, an error message is sent to the master, along with the error code No. 4. In each case, the channel No. 0 is given as faulty, independent of the really involved channel. The error message is kept up for a period of at least 5 seconds, even if the short-circuit or overload has been remedied in a shorter time.

For further information concerning diagnosis, see the descriptions of the central units and couplers used as bus masters.

## Technical Data 07 DK 93-I

In general, the technical system data listed under "System data and system configuration" in chapter 1 of volume 2 of the "Advant Controller 31" system description are valid. Additional data or data which are different from the system data are listed as follows.

### Connectors and terminals

Power supply 24 V DC	Screw-type terminals max. 1.5 mm <sup>2</sup> inside the housing, PG9 gland for cable
CS31 bus line	Screw-type terminals max. 1.5 mm <sup>2</sup> inside the housing, PG9 gland for cable
8 inputs	4 x 5-pole M12 connectors (female), 2 inputs per connector
4 outputs	4 x 5-pole M12 connectors (female)

### Power supply

Rated supply voltage	24 V DC
Current consumption, without output loads	max. 80 mA
Supply current for the outputs	max. 8 A
Conductor cross section	max. 1.5 mm <sup>2</sup> (with inserted jumper) max. 2.5 mm <sup>2</sup> (without inserted jumper)
Internal fuse (under the cover)	10 A, slow-acting, 5 x 20 mm

### Inputs

Number of inputs per module	8
Signal level of the inputs	with signal 1 11 - 30 V with signal 0 0 - 5 V
Signal input current with signal 1	approx. 8 mA
Input signal delay	approx. 1 ms
Short-circuit protection for sensors	PTC, $I_k \geq 1.6$ A

### Outputs

Number of outputs per module	4 (overload and short-circuit proof, electrically not isolated)
Signal level of the outputs at signal 1	like L+, max. internal voltage loss 0.1 V
Output load capability	
max. current per output	2 A, 100 % ED
lamp load per output	max. 50 W
total switching current	max. 8 A
Switching frequency	with inductive load max. 1 Hz with resistive load max. 100 Hz
Short-circuit and overload protection	electronically
Short-circuit indication	yes, with a red LED
Limitation of output voltage, if an inductive load is switched off	by an integrated suppressor diode

## Interfaces

Transmission standard between the central unit and input/output modules	EIA RS-485 (CS31 system bus)
Bus transmission time	387 $\mu$ s

## LED indicators

Input signals	1 yellow LED per channel
Output signals	1 yellow LED per channel
Bus Error	1 red LED
Overload (short-circuit or overload)	1 red LED (lights up when at least one output is short-circuited or overloaded)
Input Overload (short-circuit or overload)	1 red LED (lights up when there is an overload or a short-circuit at the supply voltage for the sensors)
Supply Bus (power supply for bus logic)	1 green LED (lights up when the supply voltage is $\geq 18$ V)
Supply IO (power supply for inputs/outputs)	1 green LED (lights up when the supply voltage is $\geq 18$ V)

## Mechanical data

Degree of protection according to DIN 40040, IEC 529	IP 67
Dimensions (length x width x height)	220 x 63.0 x 70.5 mm
Mounting dimension	208 mm (+0.5 mm)
Weight	approx. 470 g

## Ordering data

	Order No.
Input/output module 07 DK 93-I	GJV3 0756 23 R0202
Accessories:	
5-pole M12 plug, male, "straight"	GJV3 0756 17 R0001
5-pole M12 plug, male, "bended"	GJV3 0756 18 R0001
4-pole M12 double plug, male, "straight"	GJV3 0756 24 R0001
M12 filler plug (4 plugs are provided with the module)	GJV3 0756 19 R0001

## Note:

In order to meet the degree of protection IP67, suitable cables with certain diameters must be used at the cable glands (bus, I/O connectors, supply voltage): cable diameters for I/O 4.5 mm to 6.5 mm, for supply voltage and CS31 system bus 5 mm to 10 mm. The electrical specifications for the bus cables can be found under the Advant Controller 31 system data.

Unused cable glands have to be sealed with filler plugs.





# 5 Analog modules

---

<b>5.1</b>	<b>General information for the use of analog modules</b> .....	5.1-1
<b>5.2</b>	<b>07 AI 91:</b> Analog input module, 8 inputs, configurable for temperature sensors or as voltage inputs, 12 bit resolution .....	5.2-1
<b>5.4</b>	<b>07 AC 91:</b> Analog input/output module, 16 inputs/outputs, configurable for $\pm 10$ V, 0...10 V, 0...20 mA, 8/12 bit resolution, 2 operating modes .....	5.4-1



## 5.1 General information for the use of analog modules

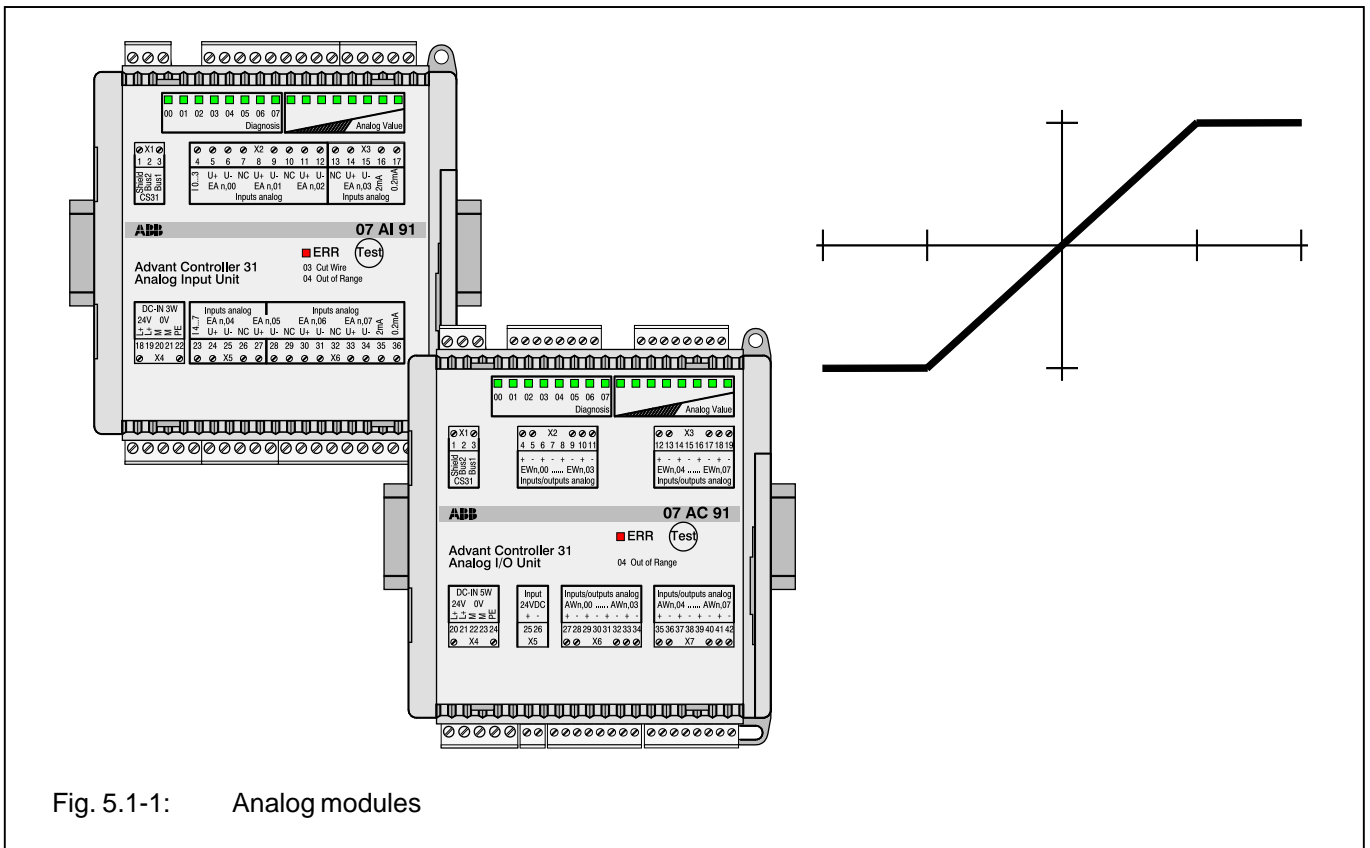

Fig. 5.1-1: Analog modules

### Contents

5.1.1	Analog input/output modules .....	5.1-1
5.1.2	Position of the relevant data bits in the 16-bit word .....	5.1-1
5.1.3	Conversion characteristics for analog modules .....	5.1-3

#### 5.1.1 Analog input/output modules

All analog input modules perform an internal analog-digital conversion. After the conversion, the analog value is represented with 8 or 12 bits, depending on the resolution. For processing and storing this relevant bits (bits which contain the analog information), a 16-bit word is available.

All analog output modules perform an internal digital-analog conversion. The digital value before the conversion (consisting of 8 or 12 relevant bits) is stored in a 16-bit word.

#### 5.1.2 Position of the relevant data bits in the 16-bit word

The figure on the next page shows the position of the relevant data bits of modules with a resolution of 8 or 12 bits.

The 50 % value means either

- Analog value 5 V in the range of 0...10 V or -10 V...+10 V
- Analog value 10 mA in the range 0...20 mA
- Analog value 12 mA in the range 4...20 mA (The distance between 4 and 20 mA is 16 mA. 50 % of 16 mA is 8 mA. The real analog input or output value is then 12 mA, after adding the offset of 4 mA.)

The following pages show in detail:

- the conversion characteristics of the analog inputs and outputs referring to
  - the resolution (8 bits or 12 bits)
  - the analog signal range
- tables showing the significances of the bits in the 16-bit word

**Bit No. in the 16-bit word**

15	14	13	12	11	10	9	8	7	6	5	4	3	2	1	0
-100 %	50 %	25 %	12.5 %	6.25 %	3.13 %	1.56 %	0.78 %	0.39 %	0	0	0	0	0	0	0

**8-bit resolution, value range 0...+ 100 %,**

in the range of - 100...+ 100 % bit 7 is 0, the sign is assigned to bit 15

15	14	13	12	11	10	9	8	7	6	5	4	3	2	1	0
-100 %	50 %	25 %	12.5 %	6.25 %	3.13 %	1.56 %	0.78 %	0.39 %	0.20 %	0.10 %	0.05 %	0.02 %	0	0	0

**12-bit resolution, value range 0...+ 100 % and -100...+100 %,**

the sign is assigned to bit 15

Fig.: Position of the relevant bits in the 16-bit word with a resolution of 8 bits and 12 bits

### 5.1.3 Conversion characteristics for analog modules

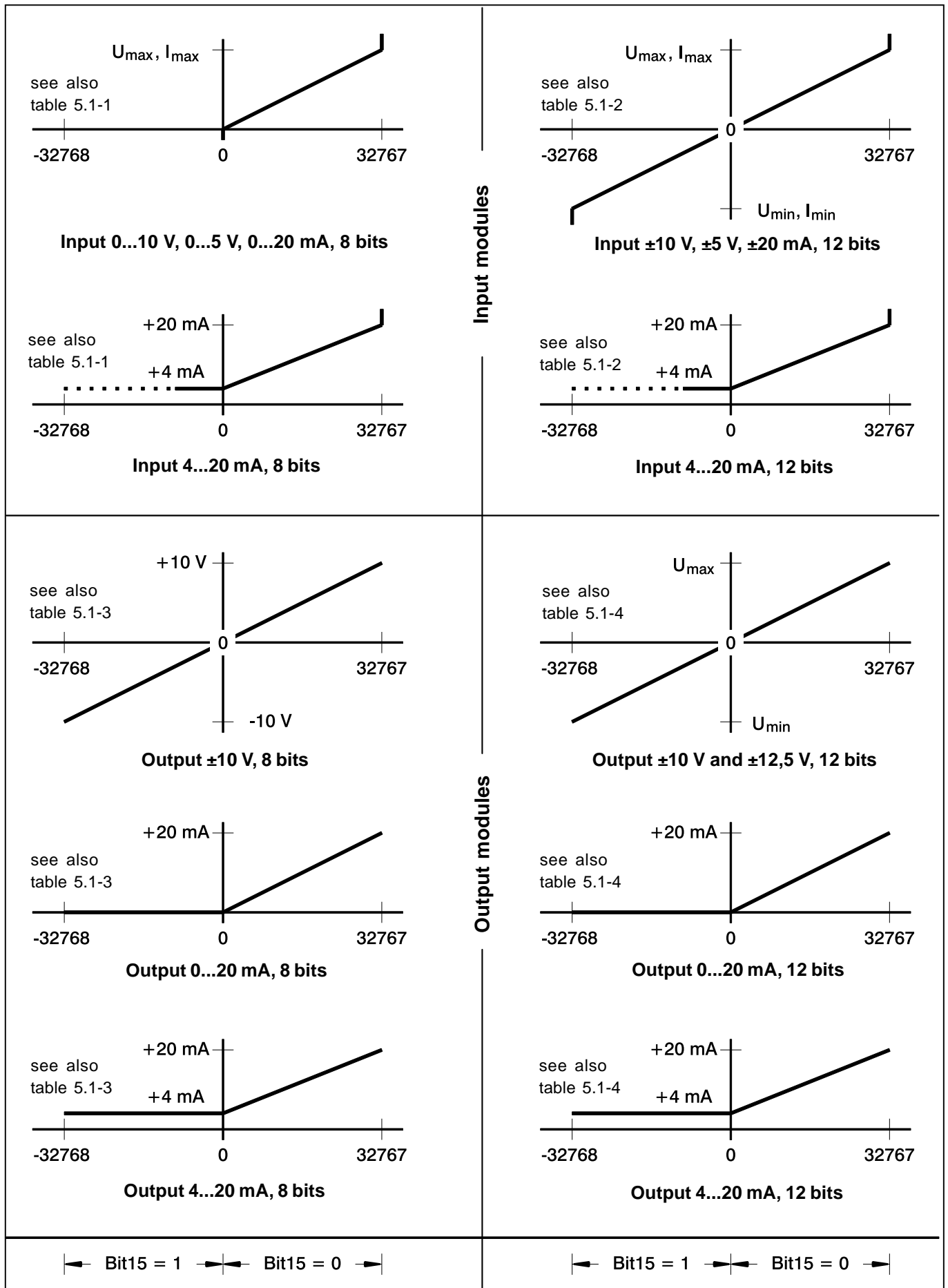

Meas. range	0 V...+10 V	0...5 V	0...20 mA	4...20 mA
Resolution	40 mV	20 mV	+ 0.08 mA	+ 0.062 mA
Max. value	+ 9.96 V	+ 4.98 V	+ 19.92 mA	+ 19.94 mA
Min. value	0 V	0 V	0 mA	4.0 mA
Offset	0 V	0 V	0 mA	4.0 mA
16-bit word				
Bit 15	0 V	0 V	0 mA	0 mA *)
Bit 14	+ 5 V	+ 2.5 V	+ 10 mA	+ 8 mA
Bit 13	+ 2.5 V	+ 1.25 V	+ 5 mA	+ 4 mA
Bit 12	+ 1.25 V	+ 0.62 V	+ 2.5 mA	+ 2 mA
Bit 11	+ 0.62 V	+ 0.31 V	+ 1.25 mA	+ 1 mA
Bit 10	+ 0.31 V	+ 0.15 V	+ 0.62 mA	+ 0.5 mA
Bit 09	+ 0.15 V	+ 0.08 V	+ 0.31 mA	+ 0.25 mA
Bit 08	+ 0.08 V	+ 0.04 V	+ 0.15 mA	+ 0.125 mA
Bit 07	+ 0.04 V	+ 0.02 V	+ 0.08 mA	+ 0.062 mA
Bit 06	0 V	0 V	0 mA	0 mA
Bit 05	0 V	0 V	0 mA	0 mA
Bit 04	0 V	0 V	0 mA	0 mA
Bit 03	0 V	0 V	0 mA	0 mA
Bit 02	0 V	0 V	0 mA	0 mA
Bit 01	0 V	0 V	0 mA	0 mA
Bit 00	0 V	0 V	0 mA	0 mA

Table 5.1-1 Significances of the bits in the 16-bit word for analog **input** modules with a **8-bit** resolution, 07 KR 91, 07 KT 9x as master

Meas. range	±10 V	±5 V	±20 mA	4...20 mA
Resolution	5 mV	2.5 mV	0.010 mA	+ 0.008 mA
Max. value	+ 10 V	+ 5 V	+ 20 mA	+ 20 mA
Min. value	- 10 V	- 5 V	- 20 mA	+ 4.0 mA
Offset	0 V	0 V	0 mA	+ 4.0 mA
16-bit word				
Bit 15	- 10 V	- 5 V	- 20 mA	0 mA *)
Bit 14	+ 5 V	+ 2.5 V	+ 10 mA	+ 8 mA
Bit 13	+ 2.5 V	+ 1.25 V	+ 5 mA	+ 4 mA
Bit 12	+ 1.25 V	+ 0.62 V	+ 2.5 mA	+ 2 mA
Bit 11	+ 0.62 V	+ 0.31 V	+ 1.25 mA	+ 1 mA
Bit 10	+ 0.31 V	+ 0.15 V	+ 0.62 mA	+ 0.5 mA
Bit 09	+ 0.15 V	+ 0.08 V	+ 0.31 mA	+ 0.25 mA
Bit 08	+ 0.08 V	+ 0.04 V	+ 0.15 mA	+ 0.125 mA
Bit 07	+ 0.04 V	+ 0.02 V	+ 0.08 mA	+ 0.062 mA
Bit 06	+ 0.02 V	+ 0.01 V	+ 0.04 mA	+ 0.031 mA
Bit 05	+ 0.01 V	+ 0.005 V	+ 0.02 mA	+ 0.015 mA
Bit 04	+ 0.005 V	+ 0.0025 V	+ 0.01 mA	+ 0.008 mA
Bit 03	0 V	0 V	0 mA	0 mA
Bit 02	0 V	0 V	0 mA	0 mA
Bit 01	0 V	0 V	0 mA	0 mA
Bit 00	0 V	0 V	0 mA	0 mA

Tabelle 5.1-2 Significances of the bits in the 16-bit word for analog **input** modules with a **12-bit** resolution, 07 KR 91, 07 KT 9x as master

\*) For input modules the most significant bit is 0, if  $I \geq 4$  mA and 1, if  $I < 4$  mA.

Meas. range	±10 V	0...20 mA	4...20 mA
Resolution	80 mV	0.08 mA	+ 0.062 mA
Max. value	+ 9.92 V	+ 19.92 mA	+ 19.94 mA
Min. value	- 10 V	0 mA	+ 4.0 mA
Offset	0 V	0 mA	+ 4.0 mA
16-bit word			
Bit 15	- 10 V	- 20 mA <sup>4)</sup>	- 16 mA <sup>5)</sup>
Bit 14	+ 5 V	+ 10 mA	+ 8 mA
Bit 13	+ 2.5 V	+ 5 mA	+ 4 mA
Bit 12	+ 1.25 V	+ 2.5 mA	+ 2 mA
Bit 11	+ 0.62 V	+ 1.25 mA	+ 1 mA
Bit 10	+ 0.31 V	+ 0.62 mA	+ 0.5 mA
Bit 09	+ 0.15 V	+ 0.31 mA	+ 0.25 mA
Bit 08	+ 0.08 V	+ 0.15 mA	+ 0.125 mA
Bit 07	0 V	+ 0.08 mA	+ 0.062 mA
Bit 06	0 V	0 mA	0 mA
Bit 05	0 V	0 mA	0 mA
Bit 04	0 V	0 mA	0 mA
Bit 03	0 V	0 mA	0 mA
Bit 02	0 V	0 mA	0 mA
Bit 01	0 V	0 mA	0 mA
Bit 00	0 V	0 mA	0 mA

Table 5.1-3 Significances of the bits in the 16-bit word for analog **output** modules with a **8-bit** resolution, 07 KR 91, 07 KT 9x as master

Meas. range	±10 V	±12,5 V	0...20 mA	4...20 mA
Resolution	5 mV	6 mV	0.01 mA	+ 0.008 mA
Max. value	+ 9.995 V	+ 12.49 V	+ 19.99 mA	+ 19.99 mA
Min. value	- 10 V	- 12.5 V	0 mA	+ 4.0 mA
Offset	0 V	0 V	0 mA	+ 4.0 mA
16-bit word				
Bit 15	- 10 V	- 12.5 V	- 20 mA <sup>4)</sup>	- 16 mA <sup>5)</sup>
Bit 14	+ 5 V	+ 6.25 V	+ 10 mA	+ 8 mA
Bit 13	+ 2.5 V	+ 3.12 V	+ 5 mA	+ 4 mA
Bit 12	+ 1.25 V	+ 1.56 V	+ 2.5 mA	+ 2 mA
Bit 11	+ 0.62 V	+ 0.77 V	+ 1.25 mA	+ 1 mA
Bit 10	+ 0.31 V	+ 0.39 V	+ 0.62 mA	+ 0.5 mA
Bit 09	+ 0.15 V	+ 0.19 V	+ 0.31 mA	+ 0.25 mA
Bit 08	+ 0.08 V	+ 0.1 V	+ 0.15 mA	+ 0.125 mA
Bit 07	+ 0.04 V	+ 0.05 V	+ 0.08 mA	+ 0.062 mA
Bit 06	+ 0.02 V	+ 0.025 V	+ 0.04 mA	+ 0.031 mA
Bit 05	+ 0.01 V	+ 0.012 V	+ 0.02 mA	+ 0.015 mA
Bit 04	+ 0.005 V	+ 0.006 V	+ 0.01 mA	+ 0.008 mA
Bit 03	0 V	0 V	0 mA	0 mA
Bit 02	0 V	0 V	0 mA	0 mA
Bit 01	0 V	0 V	0 mA	0 mA
Bit 00	0 V	0 V	0 mA	0 mA

Table 5.1-4 Significances of the bits in the 16-bit word for analog **output** modules with a **12-bit** resolution, 07 KR 91, 07 KT 9x as master

<sup>4)</sup> If bit 15 = 1, the output current is 0 mA.

<sup>5)</sup> If bit 15 = 1, the output current is 4 mA.





## 5.2 Analog Input Module 07 AI 91

8 inputs, configurable for temperature sensors or as voltage inputs,  
24 V DC, CS31 system bus

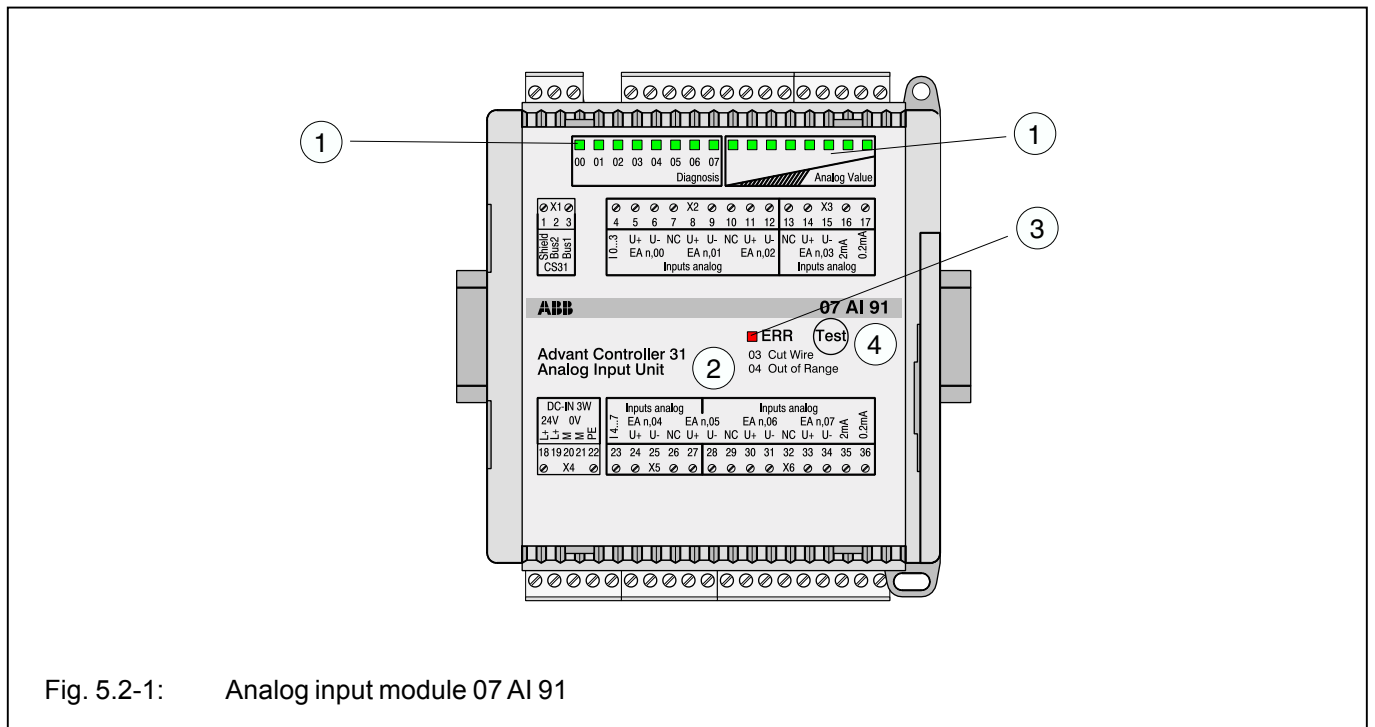

Fig. 5.2-1: Analog input module 07 AI 91

### Contents

Intended purpose .....	5.2- 1
Displays and operating elements on the front panel .....	5.2- 1
Electrical connection .....	5.2- 1
Configuration .....	5.2- 3
Measuring ranges of input channels .....	5.2- 4
Addressing .....	5.2- 9
Normal operation .....	5.2- 9
Diagnosis and displays .....	5.2- 9
Technical data .....	5.2-11
Front panel foil and outside dimensions .....	5.2-15

### Intended purpose

The analog input module 07 AI 91 is used as a remote module at the CS31 system bus. It has 8 analog input channels with the following features:

- The channels can be configured in pairs for the connection of the following temperature or voltage sensors:
  - ± 10 V / ± 5 V / ± 500 mV / ± 50 mV
  - 4...20 mA (with external 250 Ω resistor)
  - Pt100 / Pt1000 with linearization
  - Thermocouples types J, K and S with linearization
  - Only electrically isolated sensors may be used.
- The range of ± 5 V can also be used for measuring 0...20 mA with an additional external 250 Ω resistor.

- The configuration of the input channels as well as the setting of the module address are performed with the DIL switches.

The 07 AI 91 uses **one** module address (group number) in the word input range. Each of the 8 channels use 16 bits. The unit is powered with 24 V DC. The CS31 system bus connection is electrically isolated from the rest of the unit. The module offers a number of diagnosis functions (see chapter "Diagnosis and displays"). The diagnosis functions perform a self-calibration for all channels.

### Displays and operating elements on the front panel

- 8 green LEDs for channel selection and diagnosis, 8 green LEDs for analog value display of one channel
- List of diagnosis information relating to the LEDs, when used for diagnosis display
- Red LED for error messages
- Test button

### Electrical connection

The module is mounted on a DIN rail (15 mm high) or with 4 screws. The following figure shows the electrical connection of the input module.

## Connection examples for temperature sensors

The terminals **SHIELD** of the CS31 system bus and **PE** of the power supply have **no** connection inside the module

Electrical isolation

The analog part and the power input (L+ and M) are **not** electrically isolated from each other

DC/DC converter for the supply of the analog part

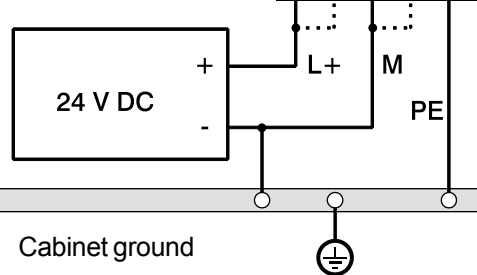

Cabinet ground

**Caution:** The process supply voltage must be included in the grounding concept of the control system (e.g. grounding of the minus terminal)

CS31 system bus

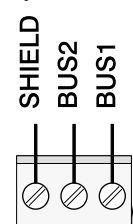

Temperature-dependent resistors

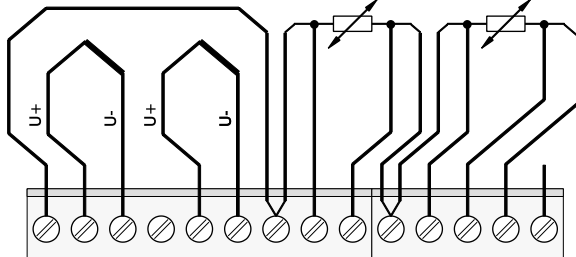

Unused channels have to be bridged as follows:

**Pt100** with 120 Ω  
**Pt1000** with 1200 Ω  
**others** with jumper wire

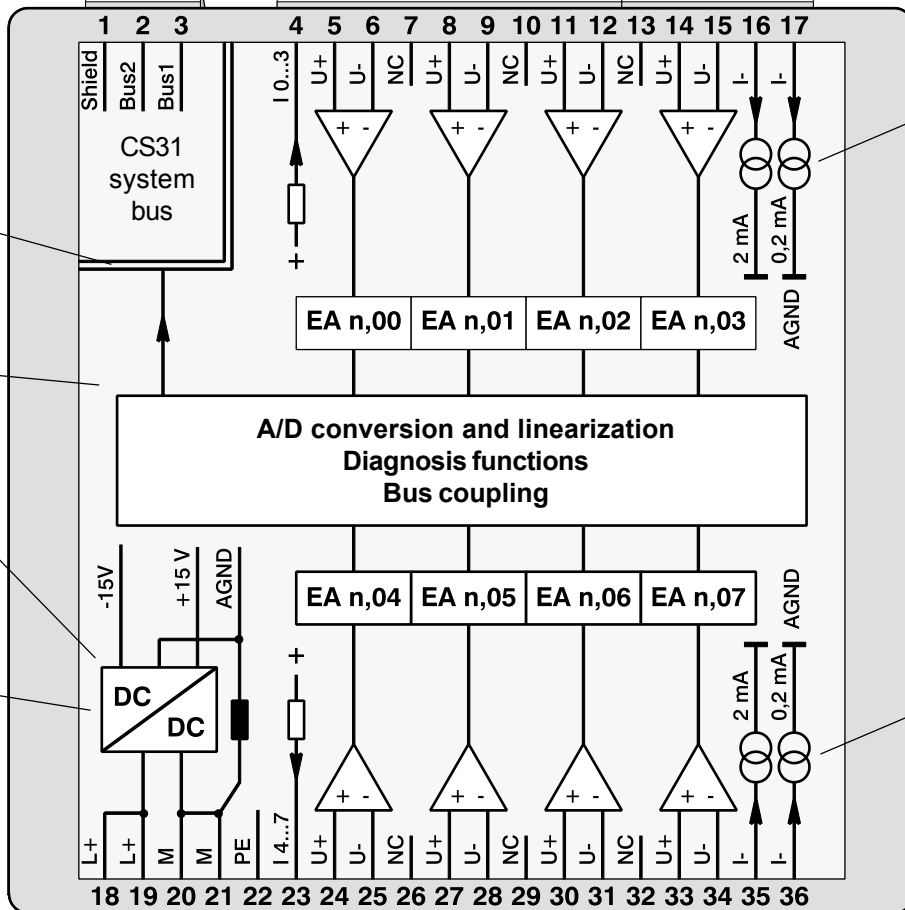

Only one of these two current sinks may be used at the same time. The used sink may only be used for channels EA 00...03.

Only one of these two current sinks may be used at the same time. The used sink may only be used for channels EA 04...07.

Unused channels have to be bridged as follows:

**Pt100** with 120 Ω  
**Pt1000** with 1200 Ω  
**others** with jumper wire

**The connections of all temperature and voltage sensors must be electrically isolated from their mounting environment.**

The cable shields of the temperature sensors are grounded to the cabinet at the entry into the cabinet.

The setting of the module address as well as the configuration of the analog channels are performed with the DIL switches (see next page).

Fig. 5.2-2: Electrical connection of the analog input module 07 AI 91

## Configuration of input channels and setting of the module address at the CS31 bus

The measuring ranges for the analog channels are set in pairs (i.e. always for two channels together) using DIL switches 1 and 2. The setting of address DIL switch determines the module address, the analog value representation and the line frequency suppression (50 Hz, 60 Hz or none).

The switches are located under the slide cover on the right side of the module housing. The following figure shows the possible settings.

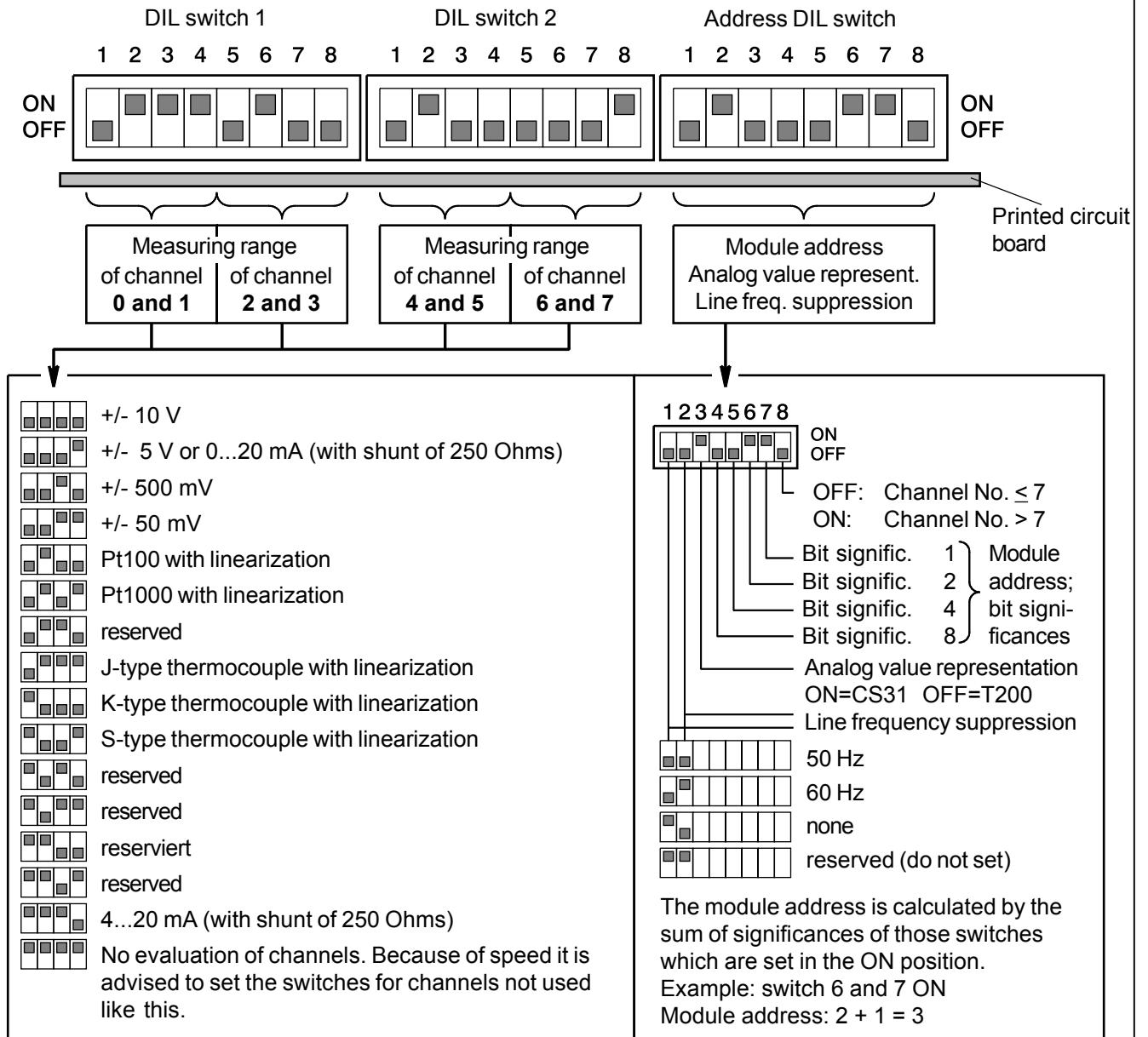

Specifications for the platinum temperature sensors are:

<b>Pt100</b>	= platinum 100 Ω at 0 °C	measuring range -50...400 °C	constant current 2 mA
<b>Pt1000</b>	= platinum 1000 Ω at 0 °C	measuring range -50...400 °C	constant current 0.2 mA

Specifications for the thermocouples are:

Type <b>J</b> = <b>Fe-CuNi</b>	0...1200 °C	iron / copper-nickel	+ = Fe	- = CuNi
Type <b>K</b> = <b>NiCr-NiAl</b>	0...1372 °C	nickel-chromium / nickel-aluminium	+ = NiCr	- = NiAl
Type <b>S</b> = <b>Pt10Rh-Pt</b>	0...1600 °C	platinum-10% rhodium / platinum	+ = Pt10Rh	- = Pt

Fig. 5.2-3: Configuration of the input channels and setting of module address at the CS31 system bus

## Measuring ranges of the input channels

All input signals are evaluated as differential signals. The sensor signal is connected with two poles to the inputs U+ and U- (example see Fig. 5.2-2). The relationship between input signal and the output numerical value is shown in figs. 5.2-7 and 5.2-8. All channels not used must be short-circuited (see also bridging of unused channels at Pt100/Pt1000 channels).

**± 10 V / ± 5 V / ± 500 mV / ± 50 mV**

The set measuring range resulting from the A/D conversion is displayed in the following number range:

-32760 ... 0 ... +32760

If input voltages overflow the measuring range, the overflow number of +32767 is output. If the input voltage underflows the measuring range, the underflow number of -32767 is output. In both cases, an error message is sent via the CS31 system bus.

All unused channels must be short-circuited.

**4...20 mA / 0...20 mA**

The following configurations must be set:

Measuring range	Setting
4...20 mA	4...20 mA
0...20 mA	± 5 V

Both channel input terminals must be externally bridged with a shunt of 250 Ω.

Unused inputs for 0...20 mA must be short-circuited. In this case, they do not need a shunt. Unused inputs for 4...20 mA can be circuited in parallel with another 4...20 mA input channel without requiring an extra shunt. In this way, error messages (underflow) can be avoided.

### Pt 100 / Pt 1000

When resistance thermometers are used, a constant current must flow through the shunt to build the necessary voltage drop for the evaluation. For this purpose the module provides two constant current sinks.

The two following figures show the connection of Pt100 and Pt1000 resistance thermometers. In these configurations the module performs a linearization of the Pt100/Pt1000 characteristic curves. The integrated current sinks of 2 mA and 0.2 mA is also considered in these measuring circuits. This way their tolerances are compensated.

The following allocation applies to the constant current sinks:

For resistance thermometers connected to terminals 5 to 15 (channels EA n,00 to EA n,03), only one of the two sinks may be used on terminals 16 or 17 (2 mA or 0.2 mA).

Setting for Pt100 with linearization:

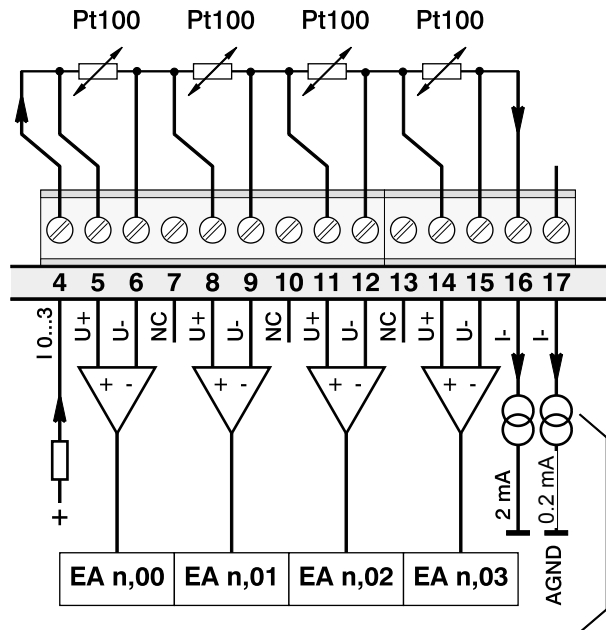

Only one of the two sinks may be used at the same time. The used sink may only be used for channels EA 00...03.

Fig. 5.2-4: Connection of Pt100 sensors

Setting for Pt1000 with linearization:

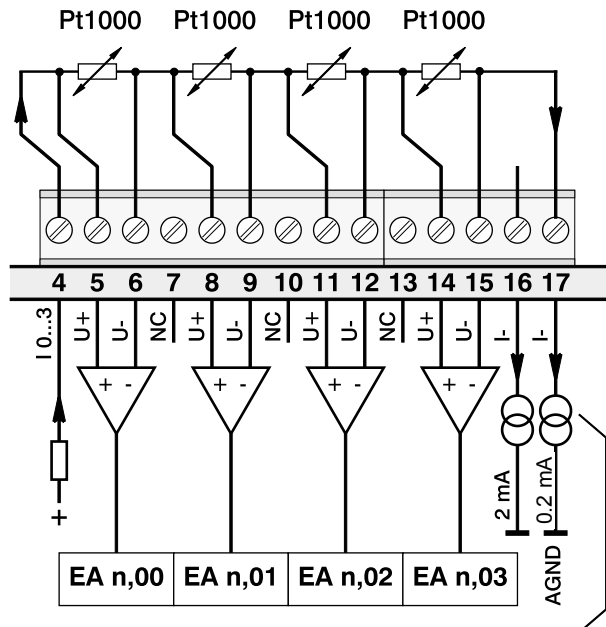

Only one of the two sinks may be used at the same time. The used sink may only be used for channels EA 00...03.

Fig. 5.2-5: Connection of Pt1000 sensors

For resistance thermometers connected to terminals 24 to 34 (channels EA n,04 to EA n,07), only one of the two sinks may be used for terminals 35 or 36 (2 mA or 0.2 mA).

Simultaneous operation of Pt100 and Pt1000 sensors is possible when one group (i.e. Pt100) is connected to the upper terminal bank and the other (i.e. Pt1000) is connected to the lower terminal bank.

Terminals 7, 10, 13, 26, 29 and 32 (marked NC) can be used as connecting points for the current loop (see also Fig. 5.2-2).

The measuring range of **-50°C...400°C** is assigned linearly to the number range of **-1022...+8190** (see also Figs. 5.2-7 and 5.2-8).

If input voltages overflow the measuring range, the overflow number of +32767 is output. If the input voltage underflows the measuring range, the underflow number of -32767 is output. In both cases, an error message is sent via the CS31 system bus.

In case of open circuit (wire break in the current loop), the numeric value of -32767 is displayed. In case of wire breakage (in a sensor circuit), the numeric value +32767 is displayed. Both cases cause an error message via the CS31 system bus.

If unused Pt100/Pt1000 channels are bridged, the wire bridge simulates 0 Ω, the measuring value for very low temperature. This causes the error message "range underflow". To avoid such error messages, bridge unused Pt100/Pt1000 channels as follows:

- Pt 100 with a resistor of 120 Ω
- Pt 1000 with a resistor of 1200 Ω

### Connection of other temperature-dependent resistors

Basically all temperature-dependent resistors can be connected in place of the Pt100/Pt1000 sensors. For a configuration you can use the settings  $\pm 5\text{ V}$ ,  $\pm 500\text{ mV}$  and  $\pm 50\text{ mV}$ . If necessary, the linearization of the resistance characteristic must be performed in the PLC user program. The integrated current sinks can be used, however, consider the following:

- The voltage drop of all resistors connected in series must not exceed
  - 7 V** (when using the current sink of 0.2 mA),
  - 2,5 V** (when using the current sink of 2 mA)
- The tolerance of the integrated current sinks of  $\pm 1.5\%$  must be considered in the tolerance calculations for the temperature measurement (no compensation as for Pt100/Pt1000).

### Thermocouples types J, K, and S

Thermocouples are connected to terminals U+ and U-, either directly or via compensating wires to both poles. Be sure to observe polarity.

The reference junction temperature sensor is integrated in the module near the terminals. When evaluating the absolute temperature, the terminals are considered as the reference junction.

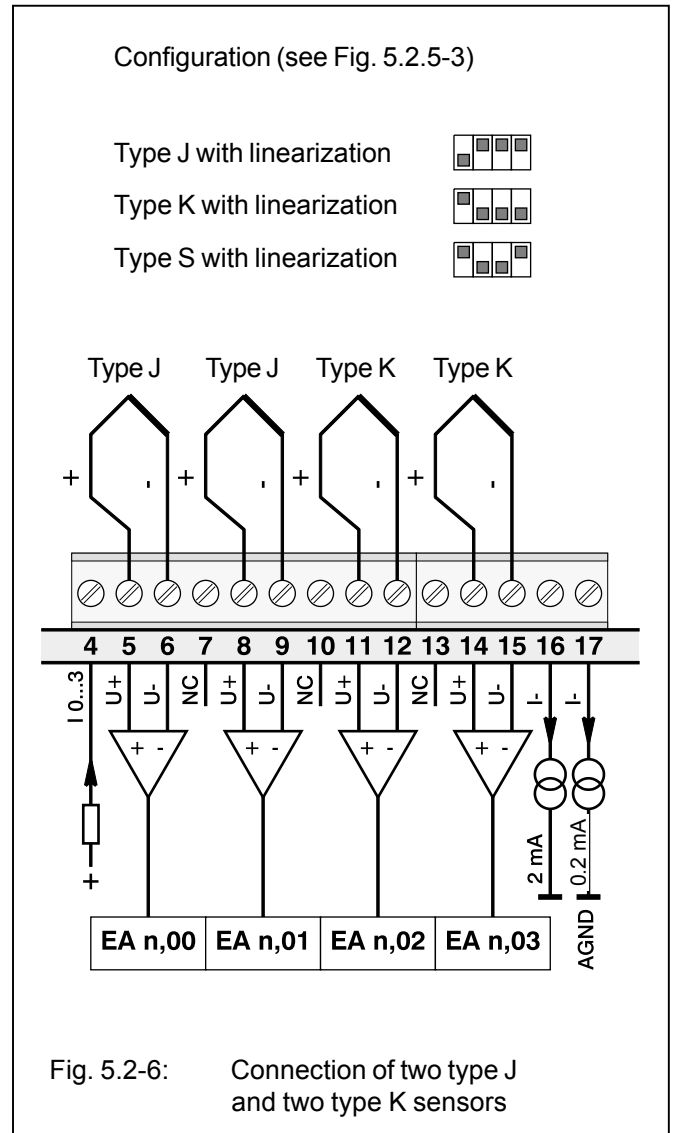

The thermoelectric voltage generated by the thermocouples is converted into binary values inside the module and then linearized according to the thermocouple type. In order to get the absolute temperature, the temperature of the reference junction is added.

The measuring value is allocated linearly to the numeric values as follows (see also Figs. 5.2-7 and 5.2-8):

- Type J:** 0°C...1200°C number range 0...24576
- Type K:** 0°C...1372°C number range 0...28096
- Type S:** 0°C...1600°C number range 0...32760

If input voltages overflow the measuring range, the overflow number of +32767 is output. If the input voltage underflows the measuring range, the underflow number of -32767 is output. In both cases, an error message is sent via the CS31 system bus. Temperatures below 0°C are considered as "underflow".

A wire break will cause the numerical value of -32767 as well as an error message via the CS31 system bus.

All channels not used must be short-circuited.

Note:

Since L type thermocouples (iron/constantan, Fe-CuNi according to DIN 43710) are similar to J type thermocouples, they also can be used in the temperature range of 0...900 °C. The slightly greater thermo emf generated by the L type thermocouple, however, pretends a little higher temperature. The following table illustrates this fact (all temperature data is referred to a reference temperature of 0 °C):

Temperature at the measuring point	Temperature evaluated by the module, if an L type thermocouple is used instead of a J type thermocouple
25 °C	25.63 °C
50 °C	51.23 °C
100 °C	101.89 °C
200 °C	203.13 °C
400 °C	405.69 °C
600 °C	609.78 °C
900 °C	920.41 °C

## Configuration of unused channels

No evaluation of the channels



Compare with configuration, Fig. 5.2-3

If the channels (in pairs) are not needed, we suggest to exclude them from the evaluation (acquisition of measuring values and processing within the software). The processing of the remaining channels is then faster. Unused channels must be short-circuited.

**Relationship between measuring values and the location of bits in a 16 bit word**

The measuring ranges for analog channels are configured in pairs (always together for two channels, see Fig. 5.2-3). When above or below a measuring range (out of range) or

when recognizing an open circuit, the numerical values +32767 or -32767 respectively will be displayed.

The following two illustrations show the evaluation functions of the module.

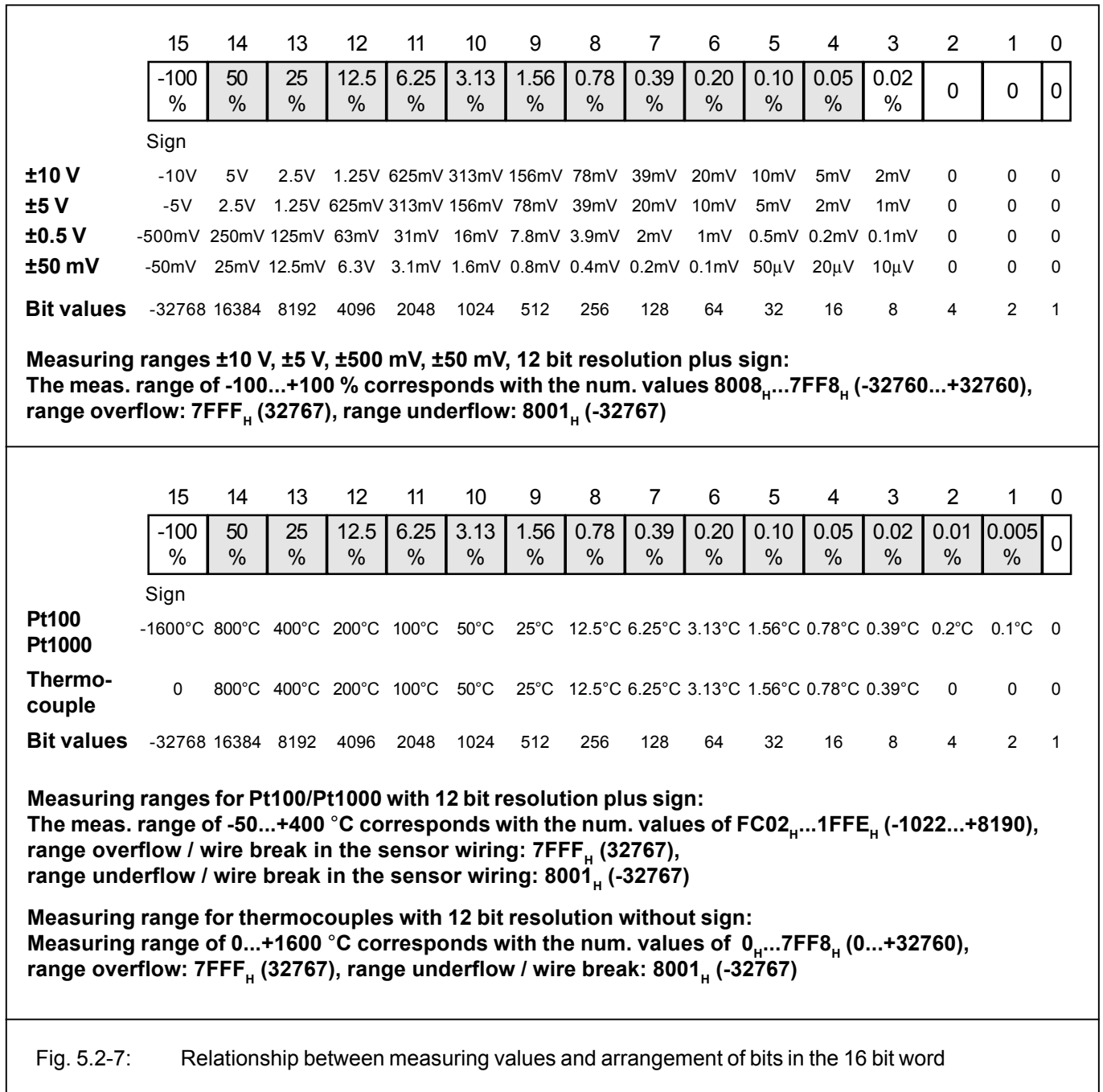

# Relationship between measuring value and numerical value, voltage and temperature inputs

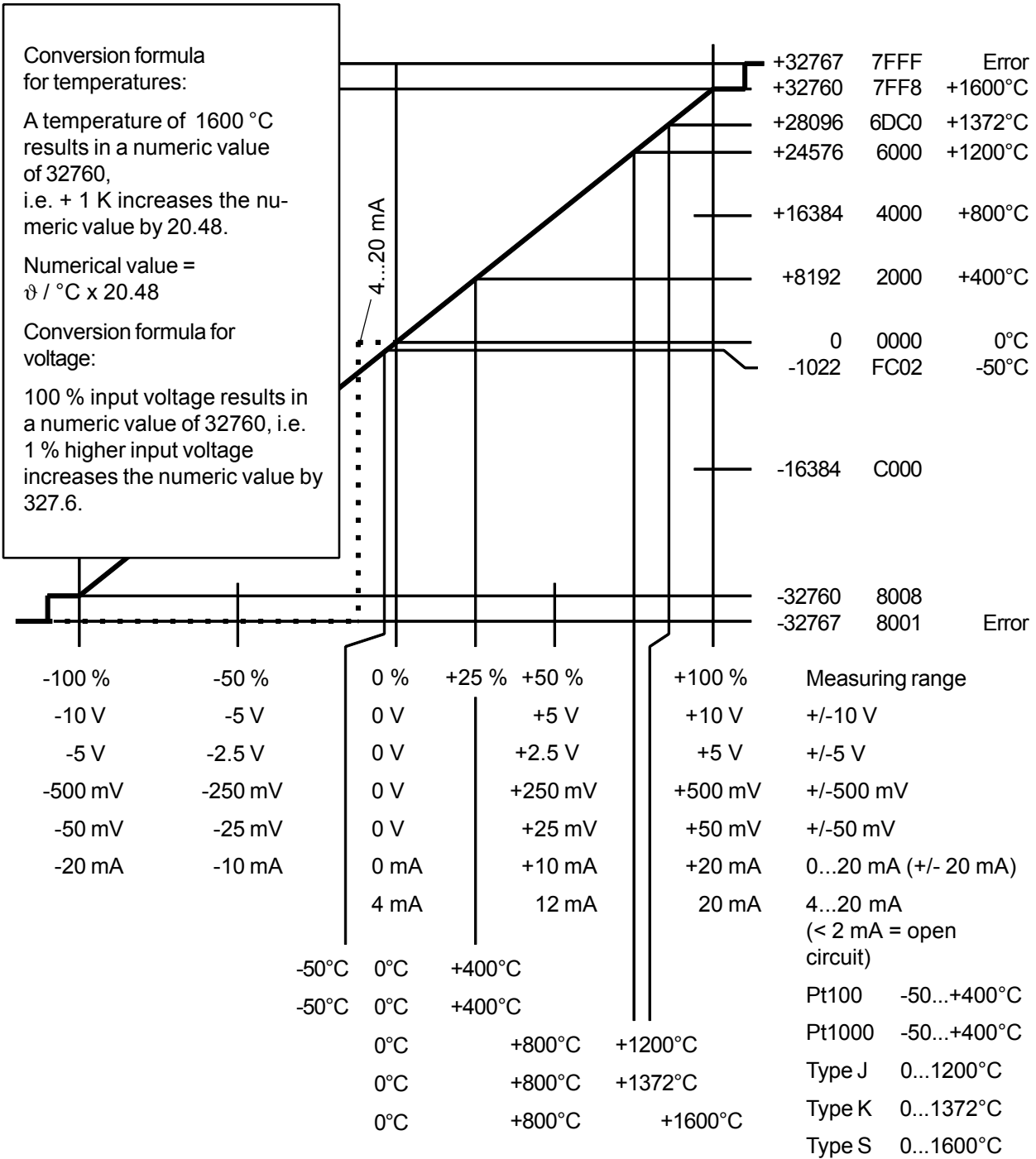

Specifications for platinum resistance thermometers are:

- Pt100** = platinum 100 Ω bei 0 °C measuring range -50...400 °C constant current 2 mA
- Pt1000** = platinum 1000 Ω bei 0 °C measuring range -50...400 °C constant current 0.2 mA

Specifications for thermocouples (pairs) are:

- |                           |             |                                    |            |          |
|---------------------------|-------------|------------------------------------|------------|----------|
| Type J = <b>Fe-CuNi</b>   | 0...1200 °C | iron / copper-nickel               | + = Fe     | - = CuNi |
| Type K = <b>NiCr-NiAl</b> | 0...1372 °C | nickel-chromium / nickel-aluminium | + = NiCr   | - = NiAl |
| Type S = <b>Pt10Rh-Pt</b> | 0...1600 °C | platinum-10% rhodium / platinum    | + = Pt10Rh | - = Pt   |

Fig. 5.2-8: Relationship between measuring value and numerical value



## Addressing

Each module must have an address installed to enable the central unit to correctly access the inputs and outputs.

**A detailed description about "Addressing" can be found in the chapter "Addressing" for the central processing unit and couplers.**

The address setting must be performed at the DIL switch under the slide cover on the right side of the module housing (see Fig. 5.2-3). If central units 07 KR 91, 07 KT 9x are used as bus master, the following address allocations apply:

Central units      07 KR 91 / 07 KT 9x			
The address switch DIL No. 8 is set to <b>OFF</b> :			
Channel	Address in PLC program	Channel	Address in PLC program
EA n,00	EW n,00	EA n,04	EW n,04
EA n,01	EW n,01	EA n,05	EW n,05
EA n,02	EW n,02	EA n,06	EW n,06
EA n,03	EW n,03	EA n,07	EW n,07
The address switch DIL No. 8 is set to <b>ON</b> :			
Channel	Address in PLC program	Channel	Address in PLC program
EA n,00	EW n,08	EA n,04	EW n,12
EA n,01	EW n,09	EA n,05	EW n,13
EA n,02	EW n,10	EA n,06	EW n,14
EA n,03	EW n,11	EA n,07	EW n,15
n: Group number of address, set with address DIL switch with switches 5...8. Addresses for 07 KR 91 / 07 KT 92 / 07 KT 93 as bus master: 00...05, as of 07 KT 94: 00...05 and 08...15.			

The module uses 8 analog inputs at the CS31 system bus.

## Normal operation

- The module initializes automatically after the power has been switched on. During this time all LEDs are switched on.

- If the CS31 system bus does not yet run, the red error LED will flash. Should an error occur during initialization, the error LED will also light up.

## Diagnosis and displays

Module 07 AI 91 offers the following diagnosis functions:

- Detection of open circuit at connection for Pt100/ Pt1000 resistance thermometers or thermocouples
- Storing and making this information available when recalled (kind of error and error location)
- Recognition of an internal module error
- Recognition of a transmission error

If one of these errors occur, the red Error LED will light up. **The error message is then sent to the central unit or to the coupler.**

For central units 07 KR 91 / 07 KT 9x the errors will be displayed as follows:

- Open circuits (cut wire)
 

Error class 4	(FK4)	M 255.14
Error number:	09	-> MW 255.08
Unit type:	01	-> MW 255.09
Group number:		-> MW 255.10
Channel number:		-> MW 255.11
- Range exceeded (out of range)
 

Error class 4	(FK4)	M 255.14
Error number:	10 dec.	-> MW 255.08
Unit type:	01	-> MW 255.09
Group number:		-> MW 255.10
Channel number:		-> MW 255.11

Using the test button, all diagnosis functions can be separately selected for each channel. Pressing the test button for the first time selects channel 0 and LED 0 will flash.

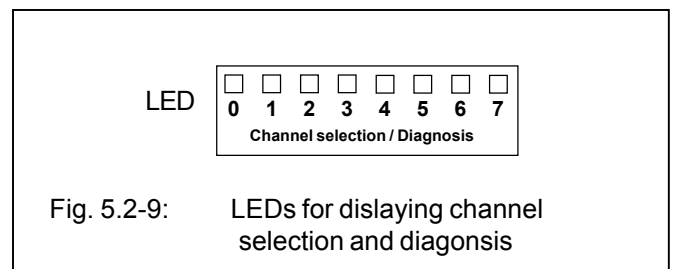

When releasing the test button, the error information for this channel is displayed by the green LEDs 0 to 7 for about 3 seconds.

Explanation of LEDs when lighting up:

- 0 not used
- 1 not used
- 2 not used
- 3 Open circuit (cut wire)
- 4 Range exceeded (out of range)
- 5 not used
- 6 not used
- 7 not used

Explanations for the LEDs ② are also printed on the front panel.

The error messages at the module and at the central unit go out as soon as the error has been corrected, when no more faults have been detected **and** when the error correction has been acknowledged.

**Acknowledgement of an error after error correction:**

- by pressing the test button for about 5 seconds, or
- using the PC, or
- using the PLC program of the central unit.

With each pressing and releasing of the test button, the procedure is repeated for the other input channels.

After checking the last channel by again pressing the test button, an LED test is performed. All LEDs of the module must light up. After that, the setting of the address DIL switch (module address at the CS31 system bus) is displayed for about 5 seconds. LED 0 shows the position of switch 1 (LEDs 0...7 are assigned to switches 1...8).

**Display of an analog value**

When the test button is not pressed, 8 LEDs display the analog value of the selected channel.

Explanation:

- all LEDs OFF -> minimum value
- all LEDs ON -> maximum value

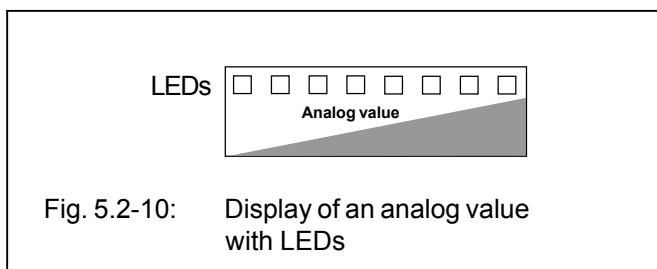

Minimum and maximum values are:

Configuration	Min. value all LEDs OFF	Max. value all LEDs ON
+/- 10 V	-10 V	+10 V
+/- 5 V	-5 V	+5 V
+/- 500 mV	-500 mV	+500 mV
+/- 50 mV	-50 mV	+50 mV
+/- 20 mA	-20 mA	+20 mA
0 V / 0 mA = 4 LEDs ON		
4...20 mA	4 mA	20 mA
12 mA = 4 LEDs ON		
Pt100 Pt1000	-50 °C -50 °C	+400 °C +400 °C
0 °C = 1 LED ON		
Thermoc. type J Thermoc. type K Thermoc. type S	0 °C 0 °C 0 °C	+1600 °C +1600 °C +1600 °C
800 °C = 4 LEDs ON		
Fig. 5.2-11: Min. and max. values for analog display		

## Technical Data for 07 AI 91

In general, the technical system data listed under "System data and system configuration" in chapter 1 of volume 2 of the "Advant Controller 31" system description are valid. Additional data or data which are different from the system data are listed as follows.

### Technical data for the complete module

Permissible temperature range during operation	0...55 °C
Rated supply voltage	24 V DC
Max. current consumption	max. 0.15 A
Max. power dissipation	max. 3 W
Protection against reversed polarity of power connection	yes
Conductor cross section for the removable connectors	max. 2.5 mm <sup>2</sup>
Number of analog input channels	8
Electrical isolation	CS31 system bus interface from the rest of the unit
Addressing and configuration	Coding switch under right housing cover
Diagnosis	see chapter "Diagnosis and displays"
Operation and error displays	total of 17 LEDs, see chapter "Diagnosis and displays"

### Technical data for analog inputs (applies to all settings)

Number of channels per module	8 (each configurable in pairs)
Electrical isolation	from CS31 system bus
Line frequency suppression	can be configured for 50 Hz, 60 Hz, or none
Input delay	0 (no RC combination)
Line frequency hum suppression (software filter)	20.0 ms at 50-Hz suppression 16.7 ms at 60-Hz suppression
Permissible input overvoltage	max. +/- 30 V
Updating period per channel incl. input delay and conversion time	
- suppression 50/60 Hz	typ. 100 ms
- no suppression	typ. 30 ms
- when using thermocouples and suppression 50/60 Hz	typ. 150 ms

The total updating time is reduced when not all channels are used (configuration see Fig. 5.2-3).

### Voltage inputs

Input resistance	> 1 MΩ
Measuring ranges (nominal values)	+/- 10 V, +/- 5 V, +/- 500 mV, +/- 50 mV
Resolution	12 bit + sign
Total error	≤ ±0.5 % of full scale
Channels not used	must be bridged

## Current inputs 0...20 mA / 4...20 mA

By bridging the input terminals with a shunt, the voltage input can also be used for input currents. The following specifications are valid:

Current range	0...20 mA	4...20 mA
Selected measuring range	+/- 5 V	4...20 mA
Required external shunt	250 $\Omega$	250 $\Omega$
Destruction limits of the shunt	depends on its load capabilities	
Total error	$\leq \pm 0.5$ % of full scale $\pm$ tolerance of the shunt	
Channels not used	must be bridged	

## Pt100/Pt1000 input

Evaluation range with linearization	-50°C...+400°C	
Resistance of the sensors within the evaluation range		
Pt100	80.31 $\Omega$ ...247.04 $\Omega$	
Pt1000	803.1 $\Omega$ ...2470.4 $\Omega$	
Resolution	12 bit + sign (1 LSB = 0.1°C)	
Permissible total line resistance of both current-carrying lines	max. 50 $\Omega$ per sensor (in 4-wire configuration)	
Evaluation error within the range of -50...+400°C (linearity, linearization, temperature range, resolution, adjustment)	Pt100:	+/- 0.5 % of full scale
	Pt1000:	+/- 1.0 % of full scale
Constant current sinks for the sensors		
Pt100	2 mA	
Pt1000	0.2 mA	
Power dissipation in the sensor		
Pt100	meas. value = 0°C	0.4 mW
	meas. value = 400°C	1.0 mW
Pt1000	meas. value = 0°C	0.04 mW
	meas. value = 400°C	0.1 mW
No-load voltage of the current output	< +15 V	
Permissible total voltage drop at the sensors and lines circuited in series	max. 7.0 V (current sink 0.2 mA is used) max. 2.5 V (current sink 2.0 mA is used)	
Cable length, if cables have been laid in parallel		
shielded	max. 50 m	
two-core shielded and cross section $\geq 0.5$ mm <sup>2</sup>	max. 200 m	

## Unused input channels:

If unused Pt100/Pt1000 channels are bridged, the wire bridge with 0  $\Omega$  simulates the measuring value of a very low temperature. This will cause the error message "range underflow". To avoid such error messages, bridge unused Pt100/Pt1000 channels as follows:

Pt 100	with a resistor of 120 $\Omega$
Pt 1000	with a resistor of 1200 $\Omega$

## Connection of other temperature-dependent resistors:

Basically all temperature-dependent resistors (PTC, NTC) can be connected instead of Pt100/Pt1000 sensors. For the configuration use the settings  $\pm 5$  V,  $\pm 500$  mV and  $\pm 50$  mV. If necessary, the linearization of the resistor curves must be performed in the PLC user program. The installed current sinks can be used, however, note the following:

- The voltage drop of all series connected resistors must not exceed  
**7 V** (when using current sinks of 0.2 mA),  
**2.5 V** (when using current sinks of 2 mA).
- The tolerance of the installed current sinks ( $\pm 1.5\%$ ) must be added in the tolerance calculation for the temperature measurements (no compensation as for Pt100/Pt1000).

### Input by thermocouples

Possible thermocouples	types J, K and S		
Evaluation range with linearization			
Type J	Fe-CuNi	0°C...+1200°C	at 0...57.942 mV
Type K	NiCr-NiAl	0°C...+1372°C	at 0...41.269 mV
Type S	Pt10Rh-Pt	0°C...+1600°C	at 0... 9.585 mV

The module has an internal reference junction. The temperature value of this junction is added to the temperature measured by the thermocouple.

Resolution 12 bit + sign (1 LSB = 0.4°C)

Evaluation error within the range of 0...+1600°C  
 (linearity, linearization, temperature range,  
 resolution, adjustment) +/- 0.5 % of full scale

Cable length, if cables have been laid in parallel  
 shielded max. 50 m  
 two-core shielded and cross section  $\geq 0.5 \text{ mm}^2$  max. 200 m

Unused channels have to be short-circuited

### Connection to the CS31 system bus

Interface standard EIA RS-485

Electrical isolation versus supply voltage and inputs

### Mechanical data

Mounting on DIN rail according to DIN EN 50022-35, 15 mm deep.  
 The DIN rail is positioned centrally between the upper  
 and the lower edges of the module.

Mounting with screws by 4 screws M4

Width x height x depth 120 x 140 x 85 mm

Wiring method removable terminal blocks with screw-type terminals  
 conductor cross section max. 2.5 mm<sup>2</sup>

Weight 450 g

Installation dimensions see Fig. 5.2-13

### Installation instructions

Installation position vertical, connector terminals must point upward and  
 downward

Cooling The natural convection cooling must not be blocked  
 by cable ducts or other components installed in the  
 cabinet.

**Ordering data**

Module 07 AI 91

Scope of delivery:

Order No. GJR5 2516 00 R0202

Analog input module 07 AI 91

1 3-pole terminal block

3 5-pole terminal blocks

2 9-pole terminal blocks

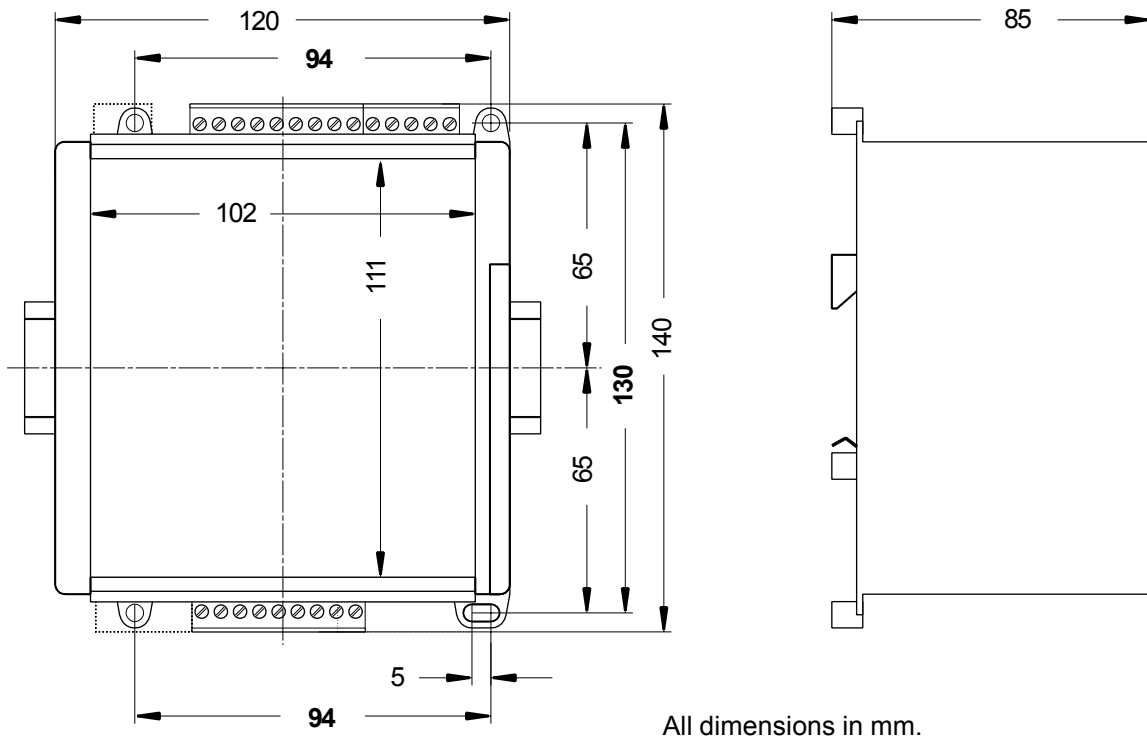
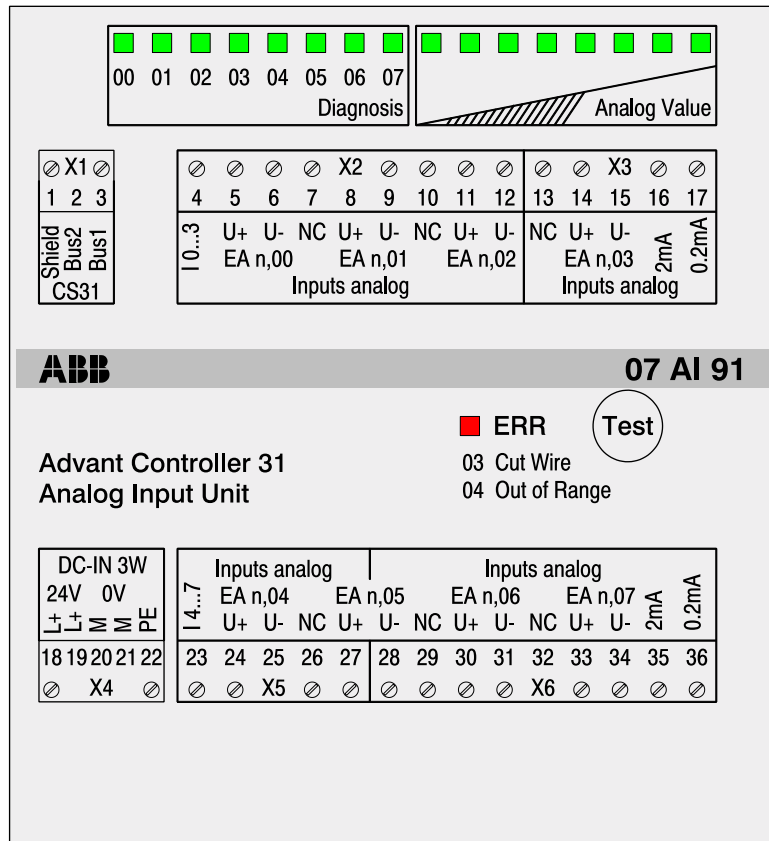

**The depth of the device is 85 mm. If a DIN rail is used for the installation, the depth must be increased by the depth of the rail.**

Fig. 5.2-13: 07 AI 91, Front panel foil, **dimensions for installation holes are in bold print**





## 5.4 Analog Input/Output Module 07 AC 91

16 inputs/outputs, configurable for  $\pm 10$  V, 0...10 V, 0...20 mA, 8/12 bit resolution, 2 operating modes, CS31 system bus

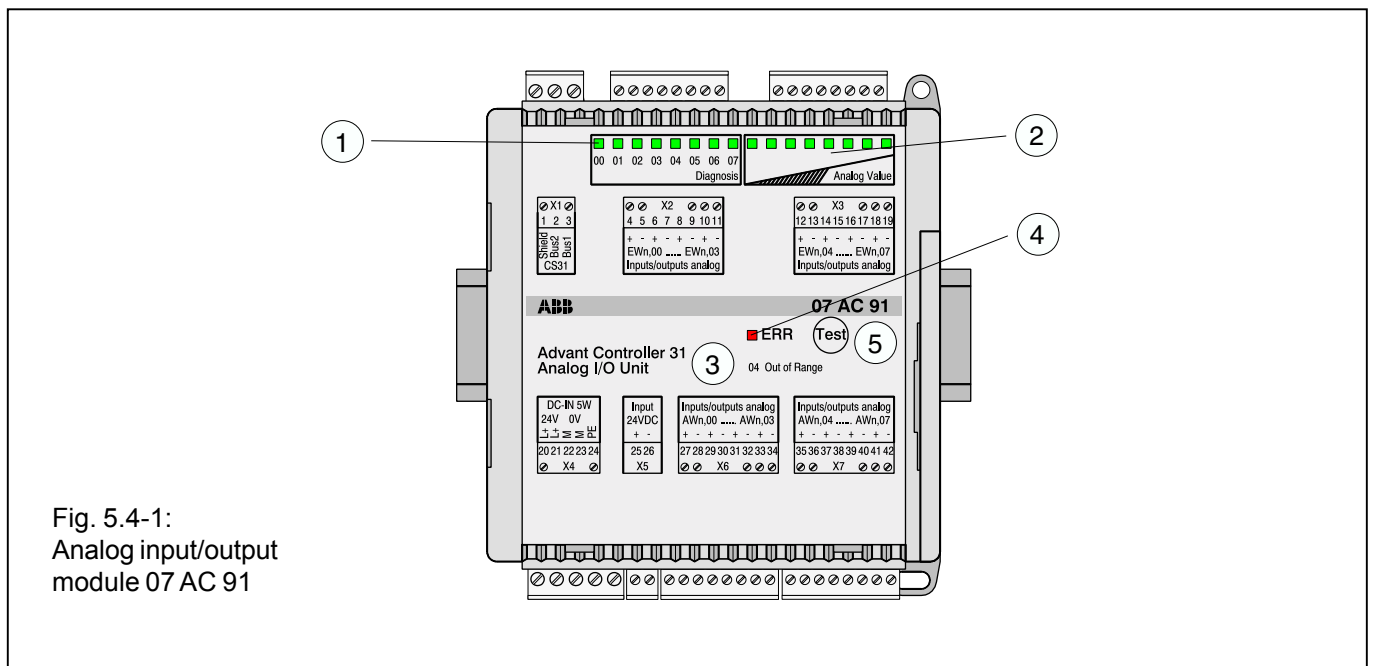

Fig. 5.4-1:  
Analog input/output  
module 07 AC 91

### Contents

Intended purpose .....	5.4- 1
Display and operating elements on the front panel .....	5.4- 1
Electrical connection .....	5.4- 1
Configuration .....	5.4- 3
Measuring ranges of analog channels .....	5.4- 4
Addressing .....	5.4- 6
Normal operation .....	5.4- 6
Diagnosis and displays .....	5.4- 6
Technical data .....	5.4- 8
Front panel foil and outside dimensions .....	5.4-11

### Intended purpose

The analog input/output module 07 AC 91 is used as a remote module on the CS31 system bus. It contains 16 analog input/output channels that can be configured in two operating modes:

- Operating mode "12 bits":  
8 input channels, individually configurable  $\pm 10$  V or 0...20 mA, 12 bit resolution plus  
8 output channels, individually configurable  $\pm 10$  V or 0...20 mA, 12 bit resolution
- Operating mode "8 bits":  
16 channels, configurable in pairs as inputs or outputs, 0...10 V oder 0...20 mA, 8 bit resolution
- The configuration is set with DIL switches.

- The PLC offers an interconnection element ANAI4\_20 for measuring signals of 4...20 mA (refer to 907 PC 331, connection element library).
- The module 07 AC 91 uses up to **eight** input words on the CS31 system bus plus up to **eight** output words. In the operating mode "8 bits", 2 analog values are packed into one word.
- The operating voltage of the unit is 24 V DC. The CS31 system bus connection is electrically isolated from the rest of the module.
- The module offers a number of diagnosis functions (see chapter "Diagnosis and displays").

### Displays and operating elements on the front panel

- ① 8 green LEDs for channel selection and diagnosis
- ② 8 green LEDs for analog value display of a channel
- ③ List of diagnosis information relating to the LEDs, when they are used for diagnosis display
- ④ Red LED for error messages
- ⑤ Test button

### Electrical connection

The module can be installed on a DIN rail (15 mm high) or with 4 screws. The figure on the next page shows the electrical connection for the input/output module.

**Operating mode "12 bits":** 8 analog inputs (terminals 4 to 19) and 8 analog outputs (terminals 27 to 42), configurable for  $\pm 10$  V or 0...20 mA, resolution 12 bits

**Operating mode "8 bits":** 16 analog channels configurable in pairs as inputs or outputs for 0...10 V or 0...20 mA, resolution 8 bits

The terminals **SHIELD** of the CS31 system bus and **PE** of the supply voltage are **not** electrically connected.

Electrical isolation

The analog part and the supply voltage (L+ and M) are **not** electrically isolated.

DC/DC converter for the supply of the analog part and the digital part

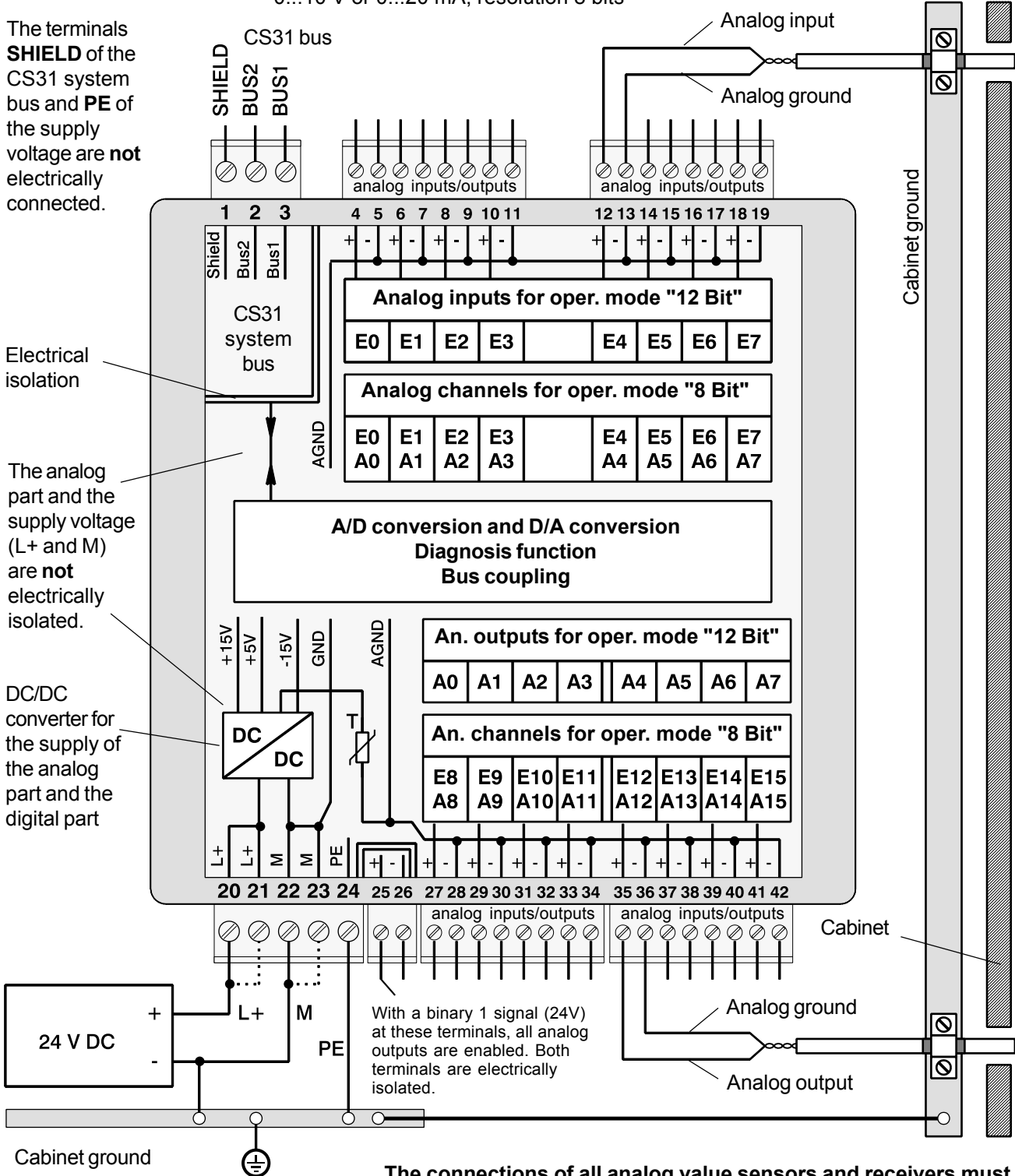

Cabinet ground

**Caution:** The process voltage must be included in the grounding concept of the control system (e.g. grounding of the minus terminal).

**The connections of all analog value sensors and receivers must be electrically isolated from their installation environment.** The cable shields of the analog wiring must be connected to cabinet ground where they enter the cabinet.

Setting of the module address and configuration of the analog channels is done with the DIL switches (see next page).

Bild 5.4-2: Electrical connection of the analog input/output module 07 AC 91

# Configuration of analog channels and settings of the module address on the CS31 bus

The 16 analog channels can be configured in two operating modes with DIL switches (located under the slide cover on the right side of the module housing (see following figure):

**Operating mode "12 bits":** 8 analog inputs (terminals 4 to 19) plus 8 analog outputs (term. 27 to 42), configurable for ±10 V or 0...20 mA, solution 12 bits

**Operating mode "8 bits":** 16 analog channels configurable in pairs as inputs or outputs for 0...10 V or 0...20 mA, solution 8 bits

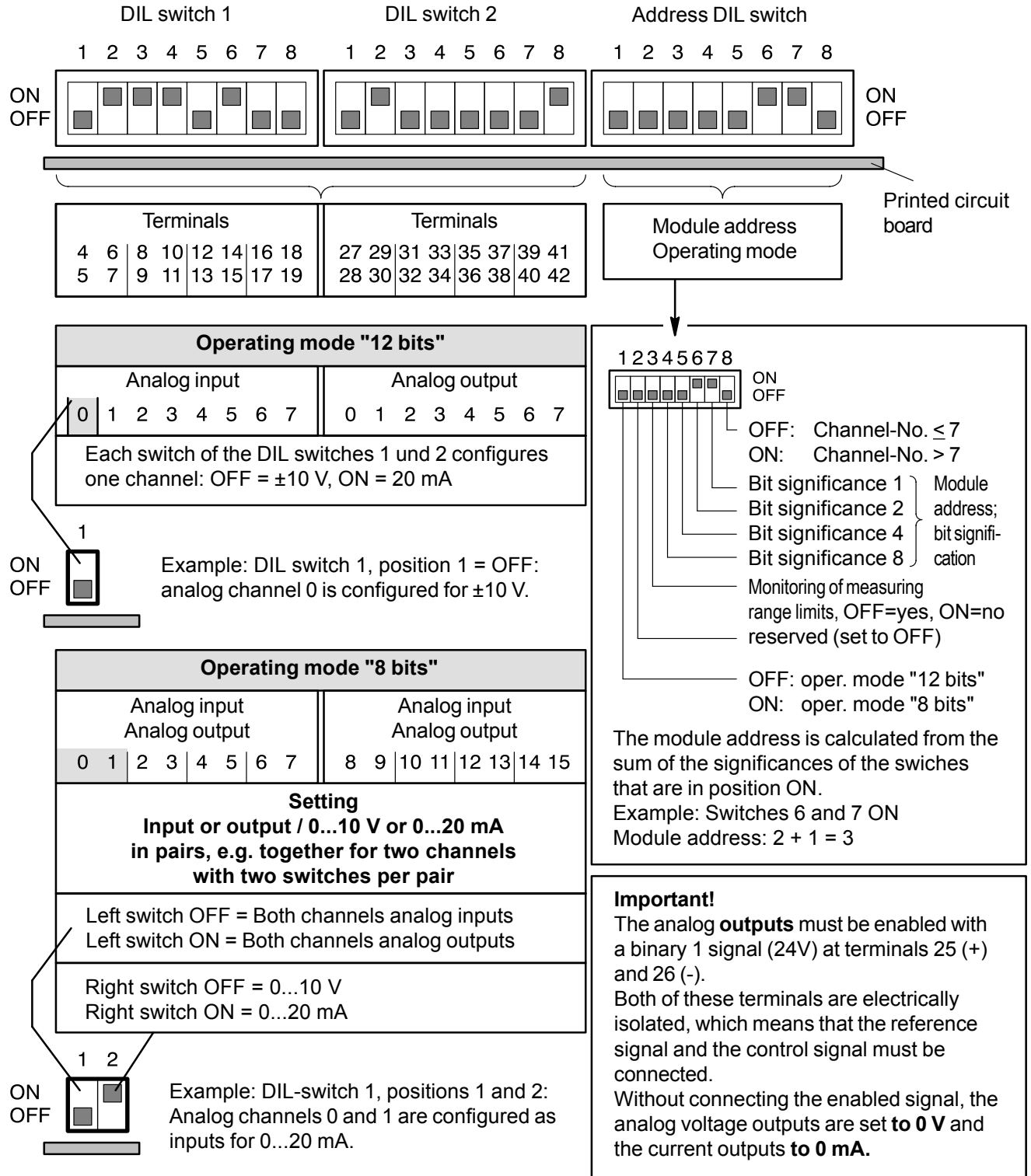

Fig. 5.4-3: Configuration of the analog channels and setting of the module address on the CS31 system bus

**Operating mode "12 bits":**

For configuration see preceding page. If input values overflow or underflow the measuring range, the values 32767 or -32767 are output.

Resolution in the control system:

All measured values will be converted with a resolution of 12 bits which are either 11 bits + sign or 12 bits without sign.

Examples:

Measuring range	Range of numerical display
-10 V...0...10 V	-32760 <sub>D</sub> ...0...32760 <sub>D</sub> 8008 <sub>H</sub> ...0000 <sub>H</sub> ...7FF8 <sub>H</sub>
0...20 mA	0...32760 <sub>D</sub> 0000...7FF8 <sub>H</sub>

The relationship between analog signal and converted numerical value is shown in the following figure.

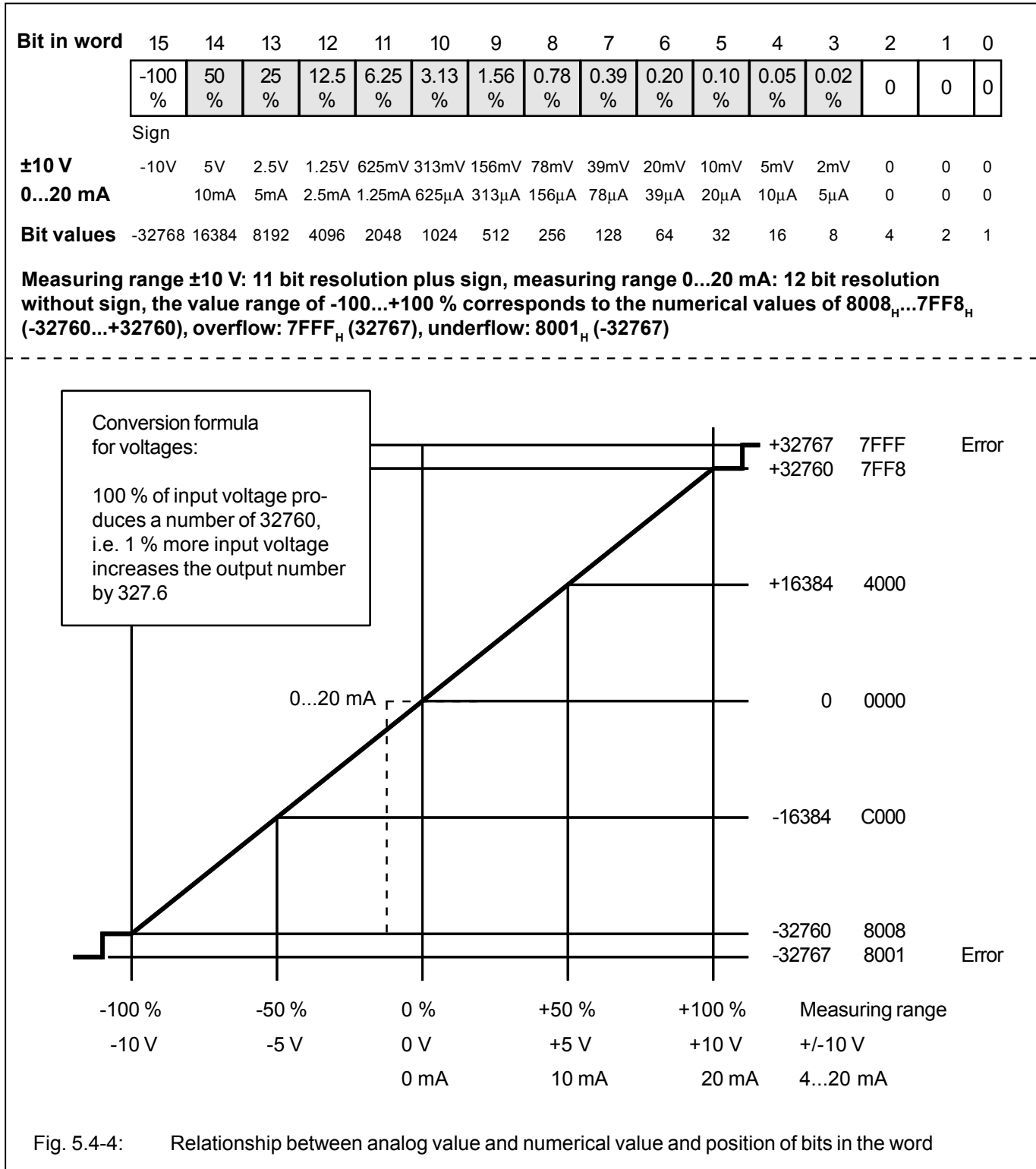

Fig. 5.4-4: Relationship between analog value and numerical value and position of bits in the word

**Operating mode "8 bits":**

For configuration please see second preceding page.

Resolution in the control system:

The converted analog values of two analog channels are packed into a word with 8 bit each (low byte and high byte).

The smallest difference that can be detected on the analog side (e.g. 40 mV in the range of 0...10 V) results in a change of the numeric value by 1 in the PLC program.

Examples:

0...10 V      0<sub>D</sub>...255<sub>D</sub>  
                   00<sub>H</sub>...FF<sub>H</sub>  
 0...20 mA    0<sub>D</sub>...255<sub>D</sub>  
                   00<sub>H</sub>...FF<sub>H</sub>

The relationship between analog signal and converted numerical value is shown in the following figure.

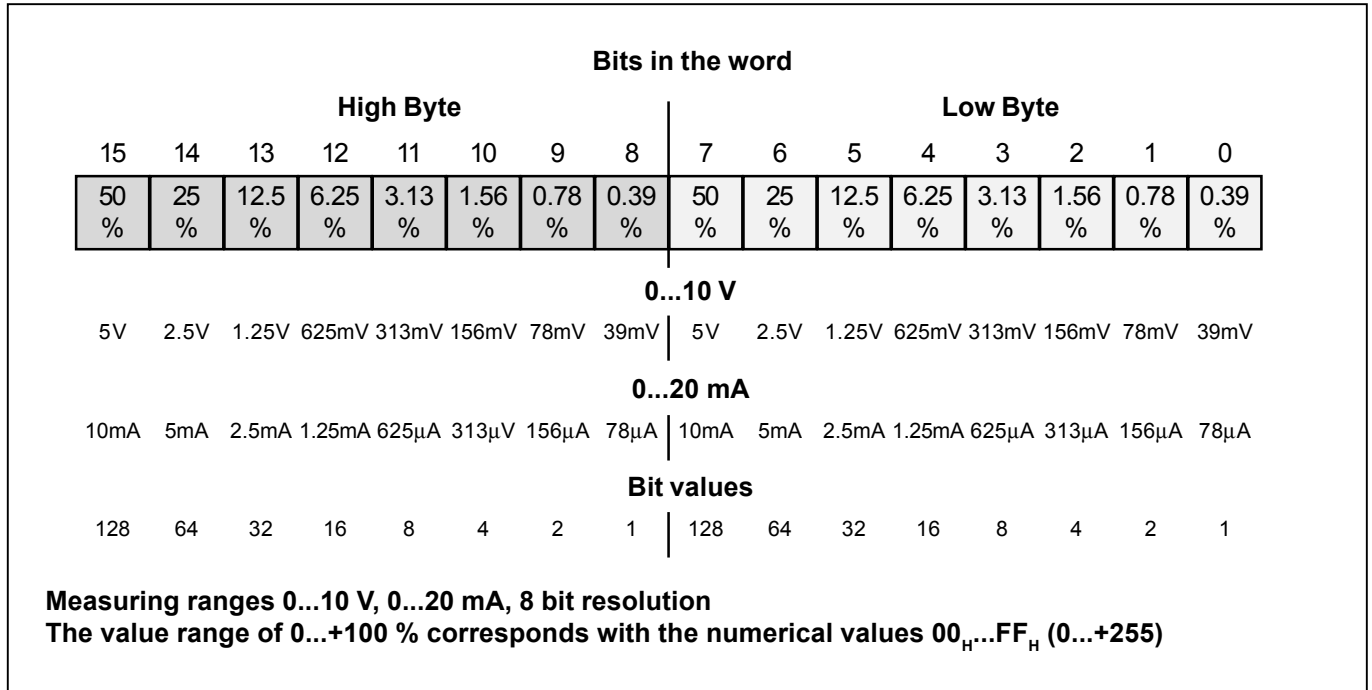

Conversion formula for voltages:  
 100 % of input voltage produces a number of 255, i. e. 1 % more input voltage increases the output number by 2.55

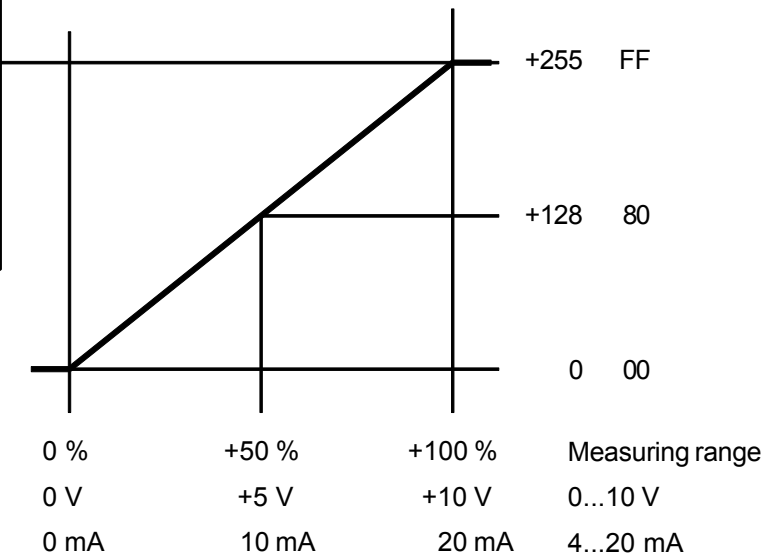

Fig. 5.4-5: Relationship between analog value and numerical value and position of bits in the word

## Addressing

Each module must have an address installed to enable the central unit to correctly access the inputs and outputs.

**A detailed description about "Addressing" can be found in the chapter "Addressing" for the central processing unit and couplers.**

The setting of the address must be done with the DIL switch located under the slide cover on the right side of the module housing (see Fig. 5.4-3). When using central units 07 KR 91, 07 KT 9x as bus master, the following address allocations result:

Central units 07 KR 91 / 07 KT 9x			
<b>Operating mode "12 bits",</b> Address DIL switch <b>No. 1</b> in <b>OFF</b> position			
Channel	Address in PLC program	Channel	Address in PLC program
E0	EW n,00	A0	AW n,00
E1	EW n,01	A1	AW n,01
E2	EW n,02	A2	AW n,02
E3	EW n,03	A3	AW n,03
E4	EW n,04	A4	AW n,04
E5	EW n,05	A5	AW n,05
E6	EW n,06	A6	AW n,06
E7	EW n,07	A7	AW n,07
<b>Operating mode "8 bits",</b> Address DIL switch <b>No. 1</b> in <b>ON</b> position			
Channel	Address in PLC program	Channel	Address in PLC program
E00	EW n,00 Lo	A00	AW n,00 Lo
E01	EW n,00 Hi	A01	AW n,00 Hi
E02	EW n,01 Lo	A02	AW n,01 Lo
E03	EW n,01 Hi	A03	AW n,01 Hi
E04	EW n,02 Lo	A04	AW n,02 Lo
E05	EW n,02 Hi	A05	AW n,02 Hi
E06	EW n,03 Lo	A06	AW n,03 Lo
E07	EW n,03 Hi	A07	AW n,03 Hi
E08	EW n,04 Lo	A08	AW n,04 Lo
E09	EW n,04 Hi	A09	AW n,04 Hi
E10	EW n,05 Lo	A10	AW n,05 Lo
E11	EW n,05 Hi	A11	AW n,05 Hi
E12	EW n,06 Lo	A12	AW n,06 Lo
E13	EW n,06 Hi	A13	AW n,06 Hi
E14	EW n,07 Lo	A14	AW n,07 Lo
E15	EW n,07 Hi	A15	AW n,07 Hi
n: Group number of the address, set at address DIL switch with switches 5...8. Addresses for 07 KR 91 / 07 KT 92 / 07 KT 93 as bus master: 00...05, as of 07 KT 94 also 08...15. Lo = low byte, Hi = high byte			

As shown in the table, the module occupies 8 analog inputs and 8 analog outputs on the CS31 system bus.

If the module is configured in operating mode "8 bits" only for inputs or only for outputs, only 8 analog inputs or 8 analog outputs are used on the CS31 system bus. In this case, not occupied input or output addresses can be used by other modules.

If the address DIL switch **No. 8** is switched to **ON**, all channel numbers change by 08, i.e. address AW n,00 changes to AW n,08, etc. This applies for the address assignments for inputs and outputs in both operation modes.

## Normal operation

- After the supply voltage was switched on, the module initializes automatically. During initialization process all LEDs are switched on.
- If the CS31 system bus does not (yet) run, the red error LED will light up. If an error occurs during the initialization process, the red error LED will also light up.

## Diagnosis and displays

The module 07 AC 91 offers the following diagnosis functions:

- Analog value is out of measuring range
- Storing this information and possibility for recall (kind of error and location of error)

If an error occurs, the red LED lights up. **The error message will be transmitted to the central unit or the coupler.**

In the central units 07 KR 91 / 07 KT 9x, the errors are displayed as follows:

- Out of range  
Error classification 4 (FK4) M 255.14  
Error recognition: 10 dec. -> MW 255.08  
Module type: \* 01/03/05 -> MW 255.09  
Group number: -> MW 255.10  
Channel number: -> MW 255.11

In the initial state after initialization, channel 0 is selected and the corresponding analog value is displayed (see also figures 5.4-6 and 5.4-7).

- \* 01 if only inputs are configured
- 03 if only outputs are configured
- 05 if inputs and outputs are configured

Diagnosis functions can be selected individually for each channel with the test button. The initial actuation of the test button selects channel 0. The diagnosis LEDs 0 to 3 display the channel number in hexadecimal code.

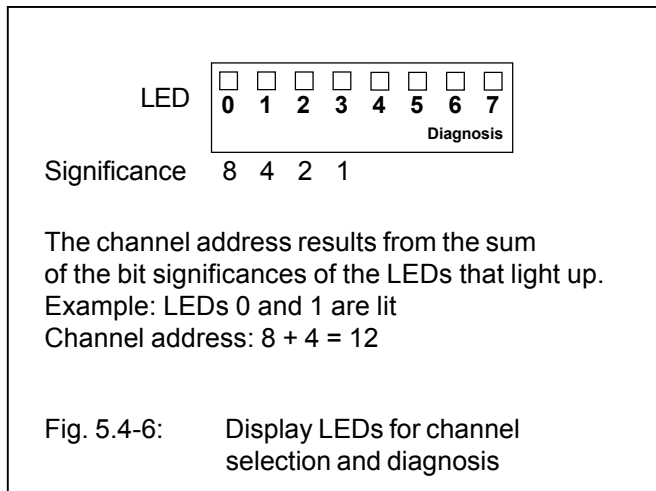

After releasing the test button, the diagnosis information of this channel is displayed for about 3 seconds by the green LEDs 0 to 7.

Explanation of lit LEDs:

- 0 not used
- 1 not used
- 2 not used
- 3 not used
- 4 Out of range
- 5 not used
- 6 not used
- 7 not used

Explanations for the LEDs are also printed in English on the front panel.

The error messages on the module and on the central unit go out again as soon as the error has been corrected, no new errors have been recognized **and** the error correction was acknowledged.

**Acknowledging an error after error correction:**

- by pressing the test button for about 5 seconds, or
- with the PC, or
- with the PLC program in the central unit

The current input has a self-protecting feature for the measuring range 0...20 mA. If the current gets too high, the current input shunt is switched off and the value for "overflow" is output. Re-activation is attempted again in increments of approx. 1 second to facilitate the correct measurement as soon as the current regains acceptable limits.

With each successive pressing and releasing of the test button, the process is repeated for the other channels.

After interrogating the last channel and pressing the test button once more, an LED test is initiated. All LEDs of the module must light up. Following this, the position of the DIL address switch is displayed for about 3 seconds (module address on the CS31 system bus). In this case, LED 0 shows the position of switch 1 (LEDs 0...7 are assigned to switches 1...8).

**Display of an analog value**

When the test button is not pressed, the analog value of the selected channel is displayed with 8 LEDs.

Explanation:

- all LEDs OFF -> minimum value
- all LEDs ON -> maximum value

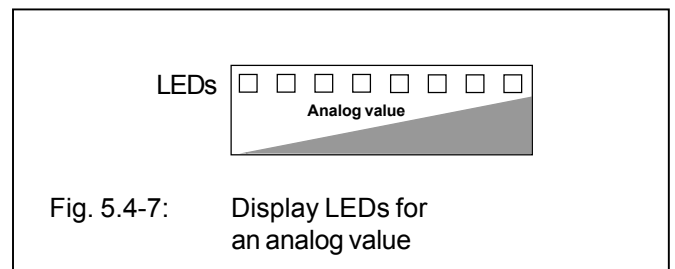

Minimum and maximum values are:

Configuration	Min. value all LEDs OFF	Max. value all LEDs ON
+/- 10 V	-10 V	+10V
0...10 V	0 V	+10 V
0...20 mA	0 mA	+20 mA

Fig. 5.4-8: Minimum and maximum values for the analog display

Example:

Configuration ±10 V and 0 V at E0

Display:

## Technical data for 07 AC 91

In general, the technical system data listed under "System data and system configuration" in chapter 1 of volume 2 of the "Advant Controller 31" system description are valid. Additional data or data which are different from the system data are listed as follows.

### Technical data for the complete unit

Permissible temperature range during operation	0...55 °C
Rated supply voltage	24 V DC
Max. current consumption	0.2 A
Max. power dissipation	5 W
Protection against reversed polarity of power connection	yes
Number of binary inputs	1 as enabling input for the analog outputs
Number of analog input channels	8 or 16, depending on the operating mode
Number of analog output channels	8 or 16, depending on the operating mode
Electrical isolation	CS31 system bus interface from the rest of the unit, 1 binary input from the rest of the unit
Address setting and configuration	Coding switch under the cover located on the right side of the housing
Diagnosis	see chapter "Diagnosis and displays"
Operation and error displays	a total of 17 LEDs, see chapter "Diagnosis and displays"
Method of connections supply terminals, CS31 system bus all other terminals	removable screw-type terminal blocks max. 1 x 2.5 mm <sup>2</sup> or max. 2 x 1.5 mm <sup>2</sup> max. 1 x 1.5 mm <sup>2</sup>
Max. length of the analog cables, two-core shielded and cross section $\geq 0.5$ mm <sup>2</sup>	100 m
Conversion error of the analog values (non-linearity, factory calibration and resolution)	typ. 0.5 %, max. 1 %
Max. permissible potential difference between terminal M (minus of the supply voltage) and terminals AGND (minus of analog inputs and outputs)	$\pm 1$ V
Common reference potential for all analog signals	AGND (minus terminal of analog inputs and outputs)
Electrical isolation of analog signals	none (see also Fig. 5.4-2).

### Technical data of the binary input (enabling input for analog outputs)

The analog outputs must be enabled by a binary 1 signal (24V) at terminals 25 (+) and 26 (-).

Signal level	0 signal (-30...+5 V)	voltage outputs are at 0 V, current outputs are at 0 mA
	1 signal (+13...+30 V)	analog outputs are active
Electrical isolation		yes, i.e. the reference potential and the control signal must be connected



### Technical data of analog inputs

Number of channels per module,	oper. mode "12 bits"	8
Number of channels per module,	oper. mode "8 bits"	up to 16
Configurability	oper. mode "12 bits"	±10 V, 0...20 mA (each channel can be configured individually)
Configurability (pairs)	oper. mode "8 bits"	0...10 V, 0...20 mA (channels can be configured in pairs)
Signalization of input signals		see diagnosis
Input resistance per channel	voltage input	> 100 kΩ
	current input	approx. 330 Ω

The current input has a self-protecting feature. If the current gets too high, the current input shunt is switched off and the value for "overflow" is output. Re-activation is attempted again in increments of approx. 1 second to facilitate the correct measurement as soon as the current regains acceptable limits.

Time constant of the input filter		470 μs for voltage, 100 μs for current	
Conversion cycle (over 8 inputs + 8 outputs)		8 ms	
Resolution	range ±10 V	oper. mode "12 bit"	5 mV (11 bit plus sign)
	range 0...20 mA	oper. mode "12 bit"	5 μA (12 bit without sign)
Resolution	range 0...10 V	oper. mode "8 bit"	40 mV (8 bit without sign)
	range 0...20 mA	oper. mode "8 bit"	80 μA (8 bit without sign)
Relationship between input signal and hexcode operating mode "12 bits"		-100 %...0...100 % =	8008 <sub>H</sub> ...0000 <sub>H</sub> ...7FF8 <sub>H</sub> (-32760...0...32760 decimal)
Relationship between input signal and hexcode operating mode "8 bits"		0...100 % =	00 <sub>H</sub> ...FF <sub>H</sub> (0...255 decimal)
Voltage inputs not used		can be bridged to increase noise immunity	
Current inputs not used		are low in ohms, can remain open	

### Technical data of analog outputs

Number of channels per unit,	oper. mode "12 bits"	8
Number of channels per unit,	oper. mode "8 bits"	up to 16
Configurability	oper. mode "12 bits"	±10 V, 0...20 mA (each channel can be configured individually)
Configurability (pairs)	oper. mode "8 bits"	0...10 V, 0...20 mA (channels can be configured in pairs)
Signalization of output channels		see diagnosis
Output loadability as voltage output (output)		max. +20 mA (source, current flows out of the output)
		max. -10 mA (sink, current flows into the output)
Output load resistance (burden), if current output		0...500 Ω
Resolution		see "analog inputs"
Relationship between output signal and hexcode		see "analog inputs"
Outputs not used		remain open

## Connection to the CS31 system bus

Interface standard	EIA RS-485
Electrical isolation	from the rest of the unit

## Mechanical data

Mounting on DIN rail	according to DIN EN 50022-35, 15 mm deep. The DIN rail is positioned centrally between the upper and the lower edges of the module.
Mounting with screws	by 4 screws M4
Width x height x depth	120 x 140 x 85 mm
Wiring method	removable terminal blocks with screw-type terminals
supply terminals, CS31 system bus	max. 1 x 2.5 mm <sup>2</sup> or max. 2 x 1.5 mm <sup>2</sup>
all other terminals	max. 1 x 1.5 mm <sup>2</sup>
Weight	450 g
Installation dimensions	see Fig. 5.4-9

## Installation instructions

Installation position	vertical, connector terminals must point upward and downward
Cooling	The natural convection cooling must not be blocked by cable ducts or other components installed in the cabinet.

## Ordering data

Module 07 AC 91	Order No. GJR5 2523 00 R0101
Scope of delivery	Analog input and output module 07 AC 91 1 2-pole terminal block (grid space 3.81 mm) 1 3-pole terminal block (grid space 5.08 mm) 1 5-pole terminal block (grid space 5.08 mm) 4 8-pole terminal blocks (grid space 3.81 mm)

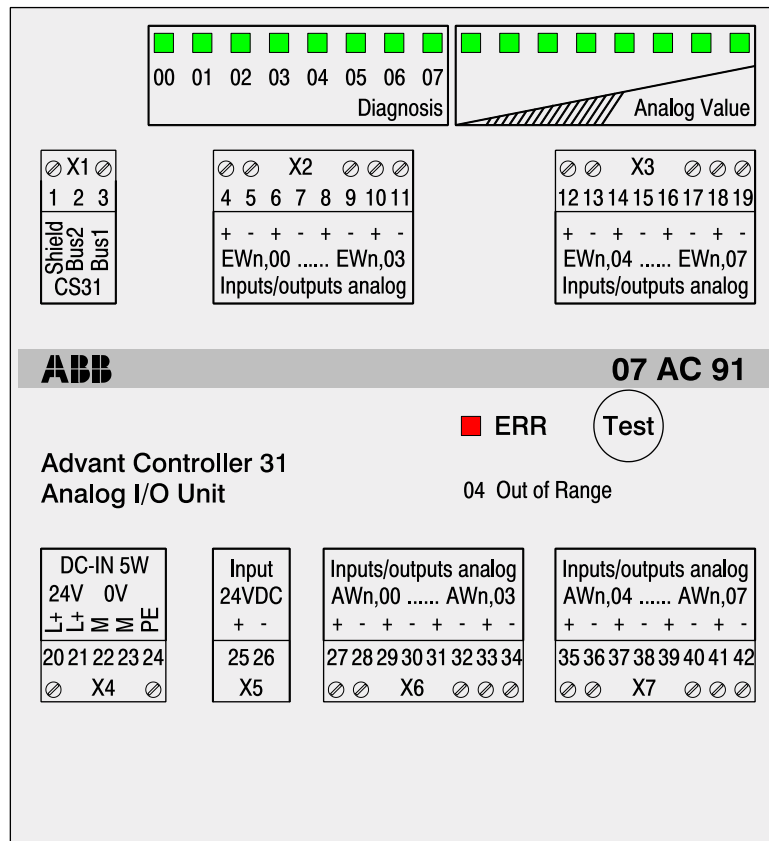

The imprint on the front panel foil shows the address assignment in operating mode "12bits"

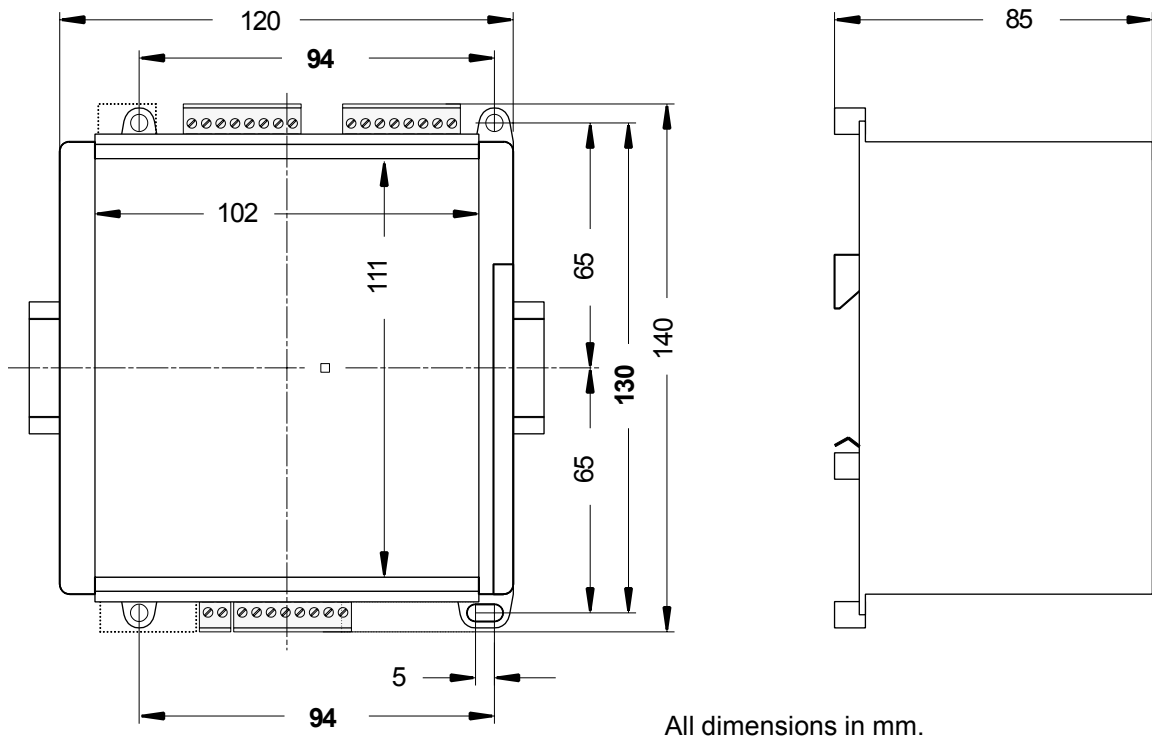

**The depth of the device is 85 mm. If a DIN rail is used for the installation, the depth must be increased by the depth of the rail.**

Fig. 5.4-9: 07 AC 91, Front panel foil and outside dimensions, dimensions for mounting holes are shown in bold print



# 7 Communication modules

---

7.1	<b>07 KP 90:</b>	Communication module, communication via RCOM protocol .....	7.1-1
7.2	<b>07 MK 92:</b>	Communication module, connecting external units .....	7.2-1
7.3	<b>07 KP 93:</b>	Communication module, with 2 serial MODBUS-RTU interfaces .....	7.3-1
7.4			
7.5			



## 7.1 Communication module 07 KP 90 R303

### Communication via RCOM protocol

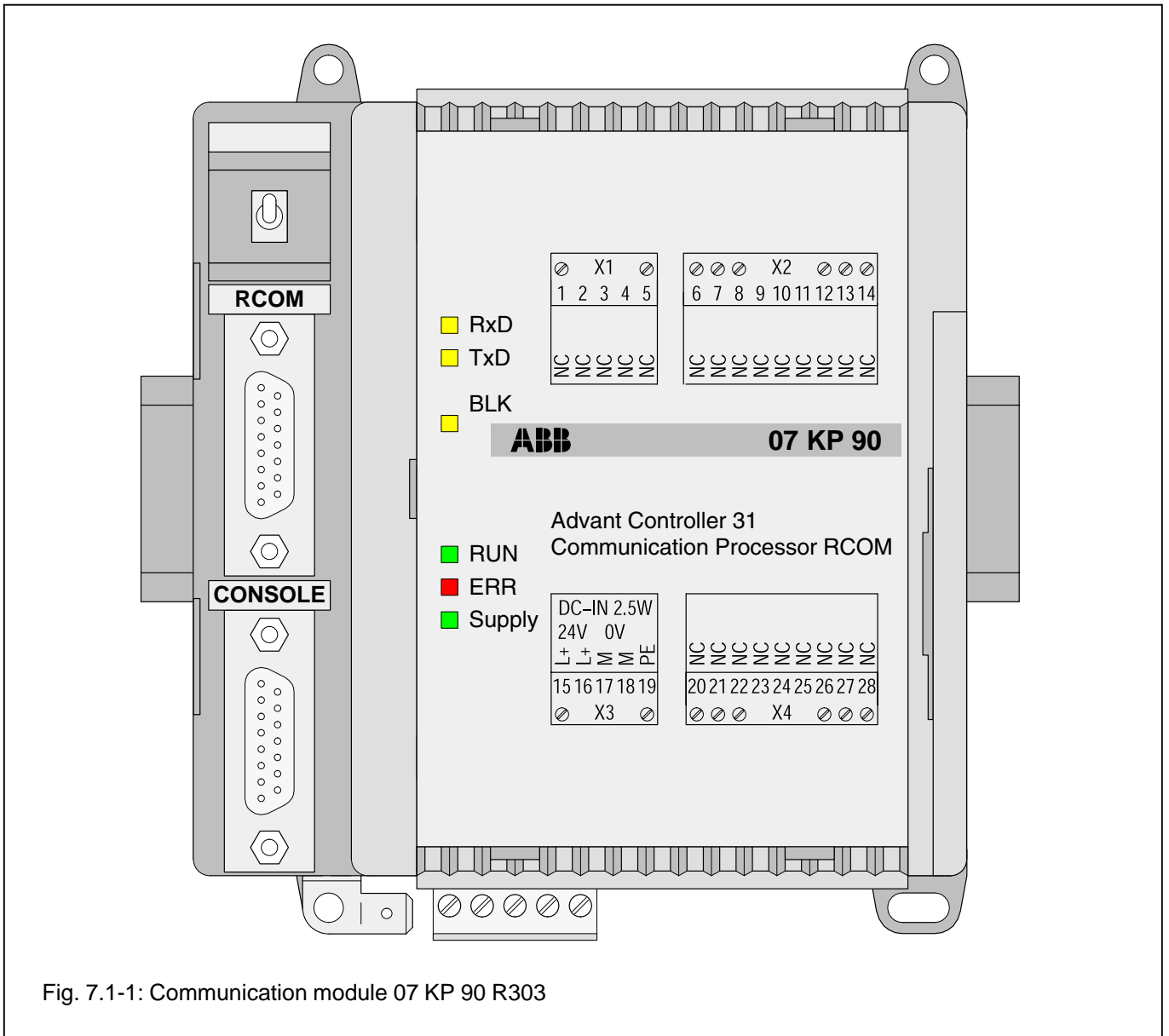

Fig. 7.1-1: Communication module 07 KP 90 R303

### Contents

7.1.1	Brief description .....	7.1-1
7.1.2	Features .....	7.1-2
7.1.3	Structure of the front panel elements .....	7.1-3
7.1.4	Electrical connection .....	7.1-4
7.1.4.1	Application example .....	7.1-5
7.1.4.2	Connection of the supply voltage .....	7.1-6
7.1.4.3	Electrical isolation and earthing instructions .....	7.1-6
7.1.4.4	Serial interfaces .....	7.1-8
7.1.4.5	Networking interface .....	7.1-9
7.1.5	Diagnosis .....	7.1-10
7.1.6	Technical data .....	7.1-11
7.1.7	System cables and adaptors .....	7.1-14

### 7.1.1 Brief description

The 07 KP 90 R303 RCOM communication module can be connected as an expansion unit to basic units such as 07 KR 91 R353, 07 KT 92 to 07 KT 97 of the decentralized automation system Advant Controller 31.

The 07 KP 90 R303 communication module permits communication via the RCOM protocol. Using this protocol it permits data exchange

- between ABB MasterPiece 200 control systems, ABB Procontic T200 systems and Advant Controller 31 systems or
- between Advant Controller 31 systems amongst themselves.

One advantage is that RCOM (**R**emote **C**OMmunication) permits large distances to be spanned.

Communication can be performed via various transmission media, such as:

- leased or private dedicated lines
- existing cable paths,
- telephone lines (dial-up connections).

Adaptation to the required transmission path can be performed by selection of various modems (e.g. VF or current loop modems, telephone modems, multidrop modems).

An RCOM network always consists of the master and one or more slaves, with the following data transmission options:

- master transmits data to a slave,
- master reads data from a slave,
- event-driven transmission: a slave can store process events with a time stamp and transfer them to the master on request (event polling).

### 7.1.2 Features

- The RCOM 07 KP 90 R303 communication module can be planned as RCOM master or slave.
- A network may have up to 254 RCOM slaves (max. 8 slaves if using MasterPiece 200, max. 30 slaves in case of dial-up mode).

- The RCOM protocol is compatible with MP200/1 with DSCA 180A. All RCOM services are available (cold start, warm start, normalization, clock synchronization, write data, read data, event polling).
- The RCOM interface for connection of the modem complies with EIA RS-232. It can also be used as an EIA RS-485 interface.
- An additional operator interface (CONSOLE) complying with EIA RS-232 is provided as a commissioning aid (indication of the communication sequence, planning telephone numbers etc.)
- Software clock; time can be used in the PLC program.
- Differences between RCOM and RCOM+, see "System technology / External couplers / 07 KP 90".

All other features of RCOM which are not mentioned in the chapter "Differences" apply correspondingly for RCOM+.

- The function block RCOM+ can be used with the communication module **07 KP 90 from index b up**.

The communication sequence is planned with function blocks from the RCOM-BIB.LIB library.



### 7.1.3 Structure of the front panel elements

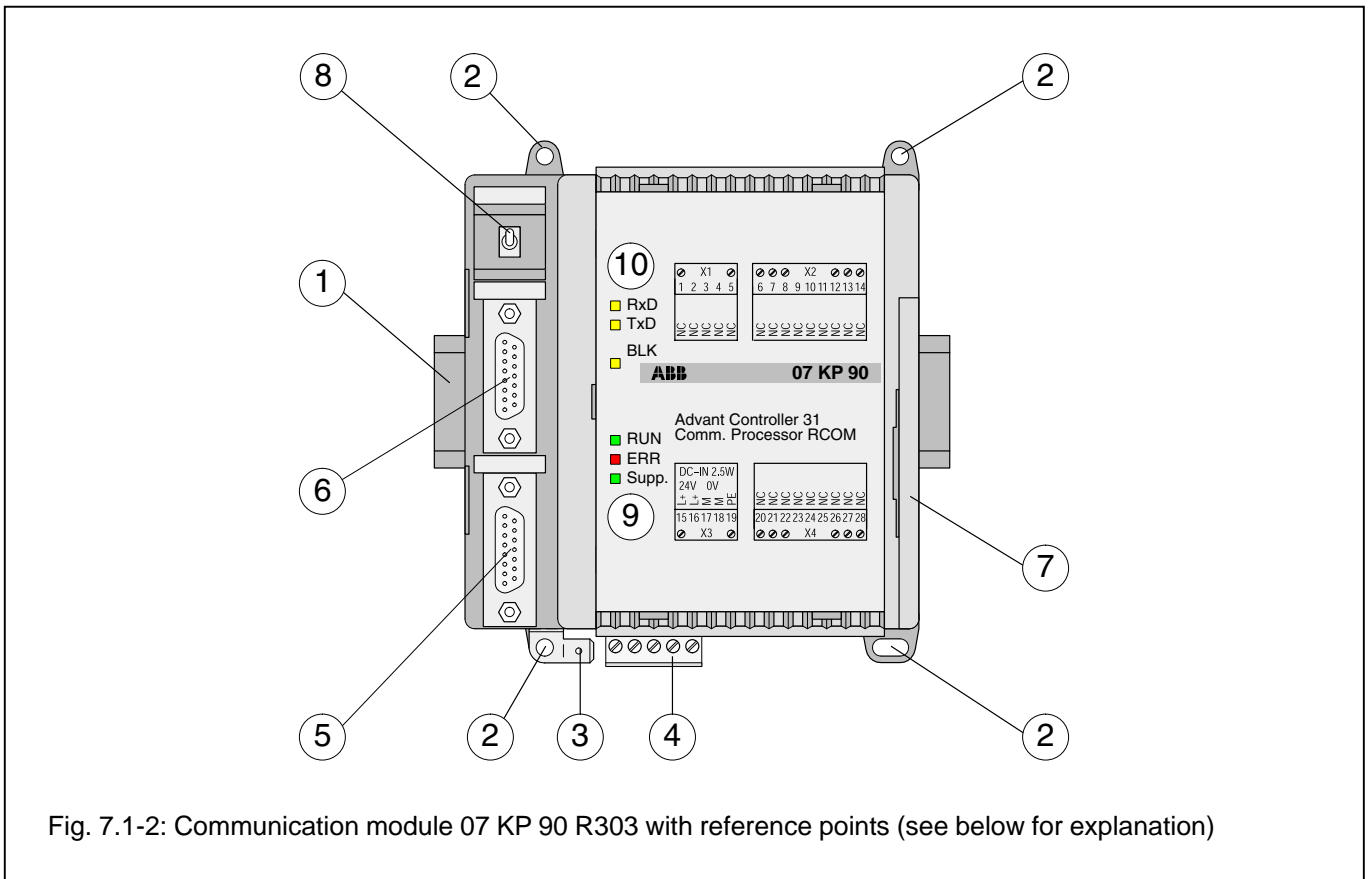
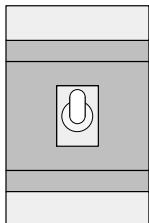

Fig. 7.1-2: Communication module 07 KP 90 R303 with reference points (see below for explanation)

- 1 Mounting the unit on a DIN rail
- 2 Mounting the unit with screws
- 3 6.3 mm Faston earthing terminal
- 4 24 V DC supply voltage
- 5 Serial interface CONSOLE
- 6 Serial interface RCOM
- 7 Networking interface to the Advant Controller 31 central unit
- 8 Switch



The switch has no function.

- 9 LED indicators see below
- 10 LED indicators see below

<p>⑩</p> <p>yellow</p> <p>yellow</p> <p>yellow</p>	<p><input type="checkbox"/> RxD</p> <p><input type="checkbox"/> TxD</p> <p><input type="checkbox"/> BLK</p>	<p>07 KP 90 is receiving an RCOM telegram</p> <p>07 KP 90 is transmitting data via the RCOM interface</p> <p>Transmission of user data blocked as the result of communication error</p>
<p>green</p> <p>red</p> <p>green</p> <p>⑨</p>	<p><input type="checkbox"/> RUN</p> <p><input type="checkbox"/> ERR</p> <p><input type="checkbox"/> Supply</p>	<p>07 KP 90 R303 is ready for RCOM communication (running)</p> <p>RCOM communication error</p> <p>Supply voltage present</p>

Refer to section 7.1.5 Diagnosis for further information

## 7.1.4 Electrical connection

### 7.1.4.1 Application example for connecting the inputs and outputs

The following illustration shows an application example with the 07 KT 97 which utilizes various possibilities for connecting inputs and outputs. Attention must be paid to the following in detail:

- The earthing measures
- Connection of the communication module 07 KP 90 R303
- Looping through the supply voltage (24 V DC) from the 07 KT 97 to the 07 KP 90 R303
- Earthing the switch cabinet mains socket
- Handling serial interfaces

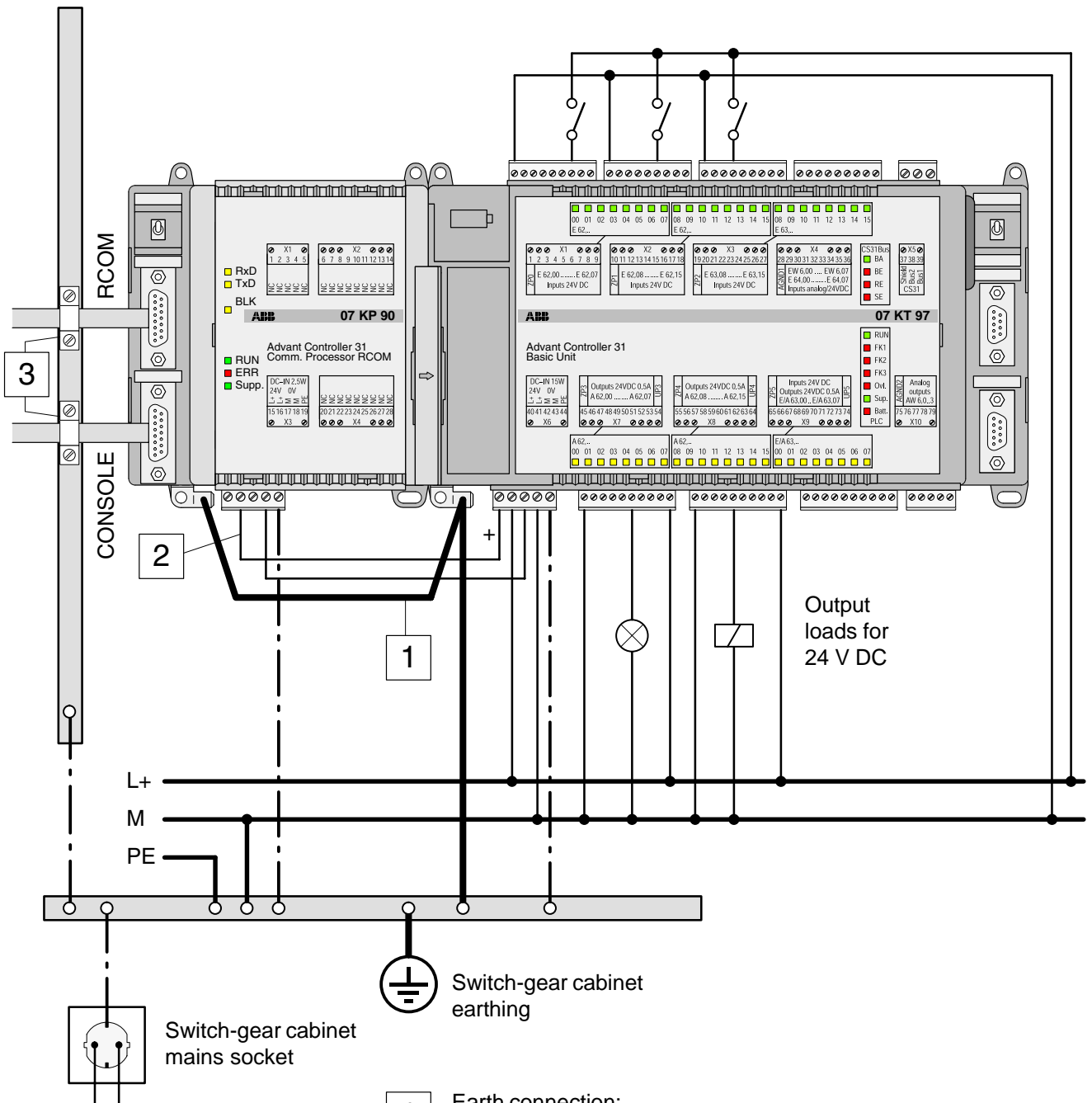

- 1 Earth connection:  
Use supplied parts (see Fig. 7.1-6)
- 2 Supply voltage:  
Short, direct connection between the modules,  
wires 15 cm, 2.5 mm<sup>2</sup> (see Fig. 7.1-6)
- 3 Cable shields:  
In the case of permanent wiring at the switch-gear cabinet inlet,  
earth via clamps and do not put shield in the plug. Otherwise,  
lay the cable shield in the plug to PGND.

Fig. 7.1-3: Application example:  
Communication module 07 KP 90 R303 at the basic unit 07 KT 97  
(Chapter 7.1.4 Electrical connection applies similarly to 07 KR 91, 07 KT 92 to 07 KT 97)

### 7.1.4.2 Connecting the 24 V DC supply voltage

The supply voltage is fed in via a 5-pole detachable terminal block.

**Important:**

**Plug and unplug terminal block only with power is off!**

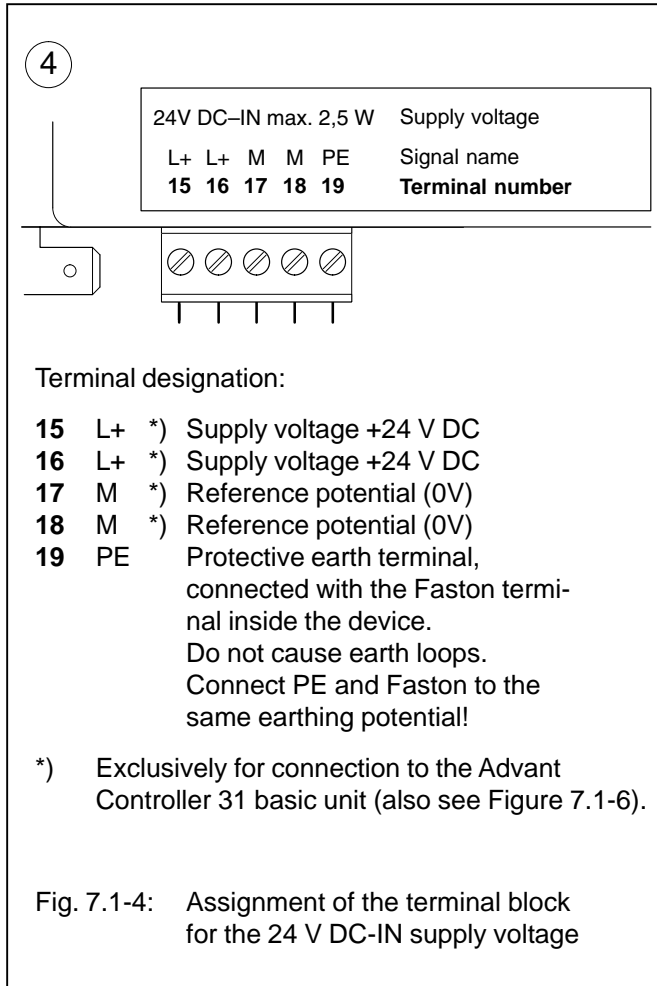

### 7.1.4.3 Electrical isolation and notes on earthing

The following illustration shows which circuit parts of the unit are electrically isolated from each other and which internal connections exist. Here, both the clearances and creepage distances and also the test voltages used correspond to DIN/VDE 0160.

The unit is connected via the 6.3 mm Faston terminal (bottom left) to the functional earth (switch cabinet earth) via a wire with a cross section of 6 mm<sup>2</sup> (also see Figure 7.1-6).

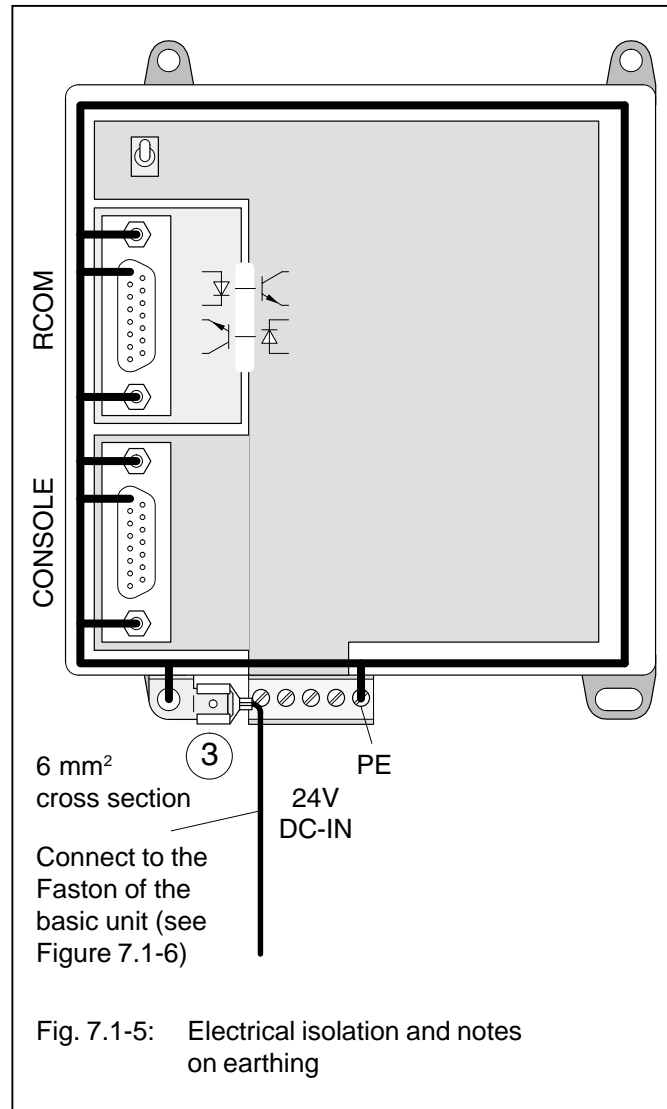

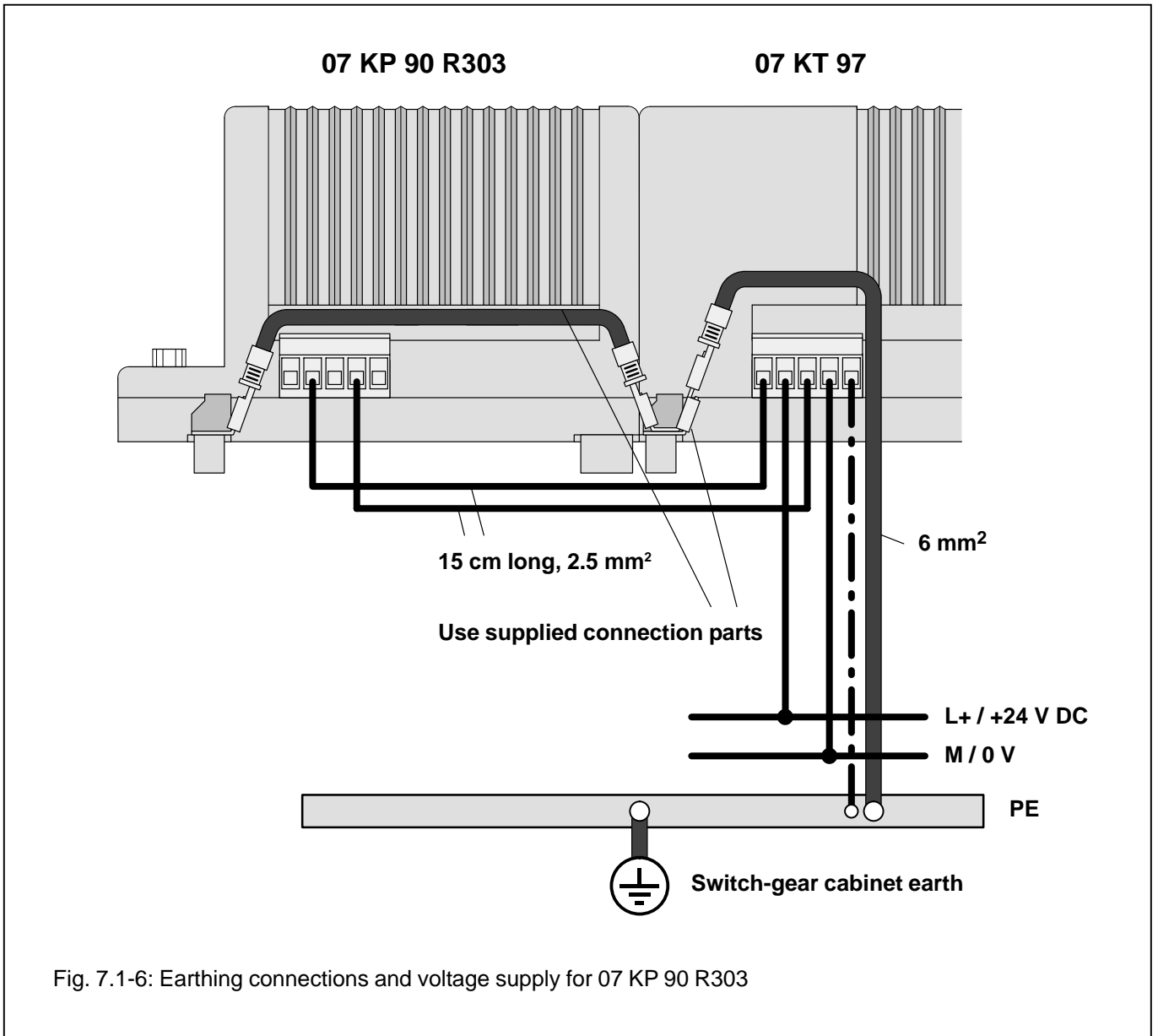

Fig. 7.1-6: Earthing connections and voltage supply for 07 KP 90 R303

### 7.1.4.4 Serial interfaces

#### Serial interface CONSOLE

A terminal can be connected to the CONSOLE interface for commissioning. The CONSOLE interface can be used to

- configure the telephone directory or configure data (only in the case of dial-up modems),

- follow the communication sequence (faultfinding during commissioning). This function can be deactivated after commissioning.

#### Serial interface RCOM

The RCOM network is connected to this interface. It is connected via a modem with standard interface.

#### Serial interface CONSOLE: Terminal assignment

Interface standard: EIA RS-232

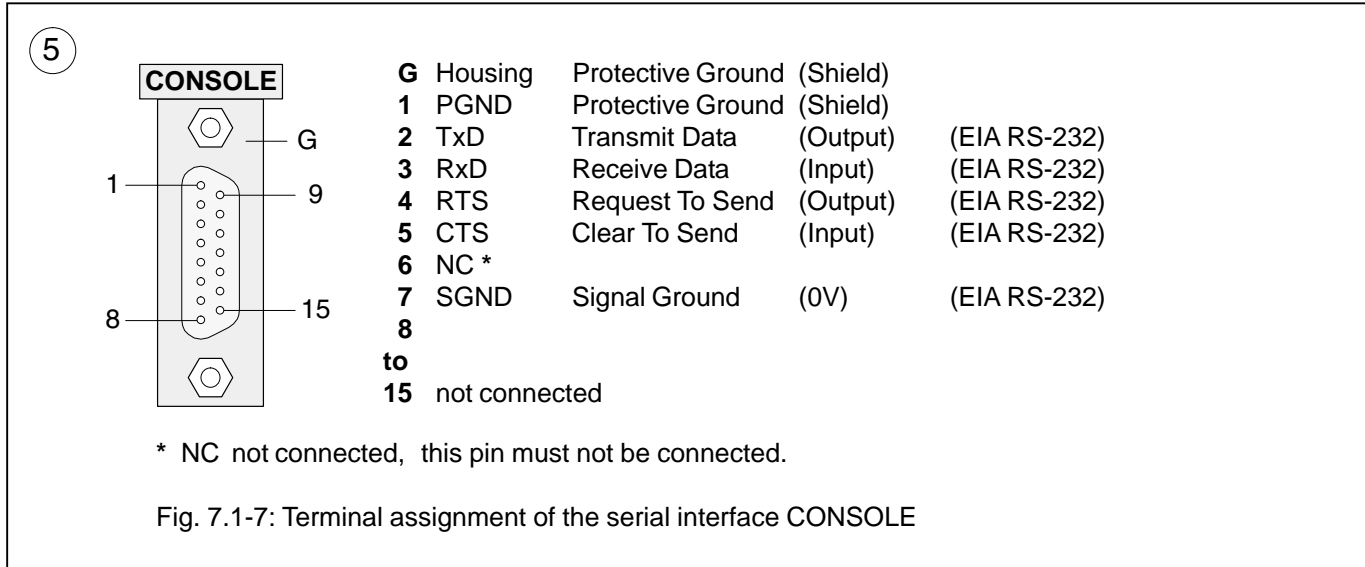

#### Serial interface RCOM: Terminal assignment

Interface standard: EIA RS-232 or EIA RS-485

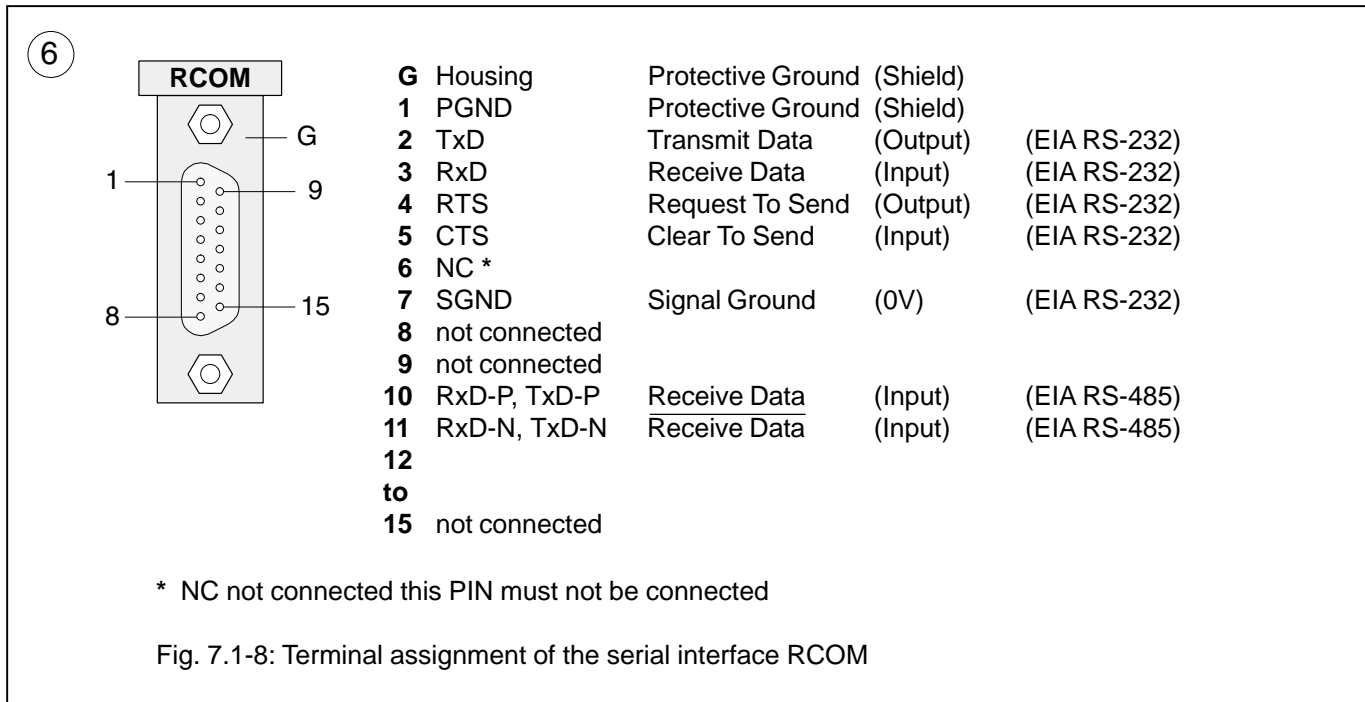

### 7.1.4.5 Networking interface 7

The networking interface, a special parallel interface, allows the 07 KP 90 R303 communication module to be connected to AC31 basic units (such as 07 KR 91 R353, 07 KT 92 to 07 KT 97). The housing of the communica-

tion module is connected to the housing of the AC31 basic unit by a snap-fit connection. The electrical connection is via a 40-pole ribbon cable with socket connector, soldered onto the 07 KP 90 R303 side.

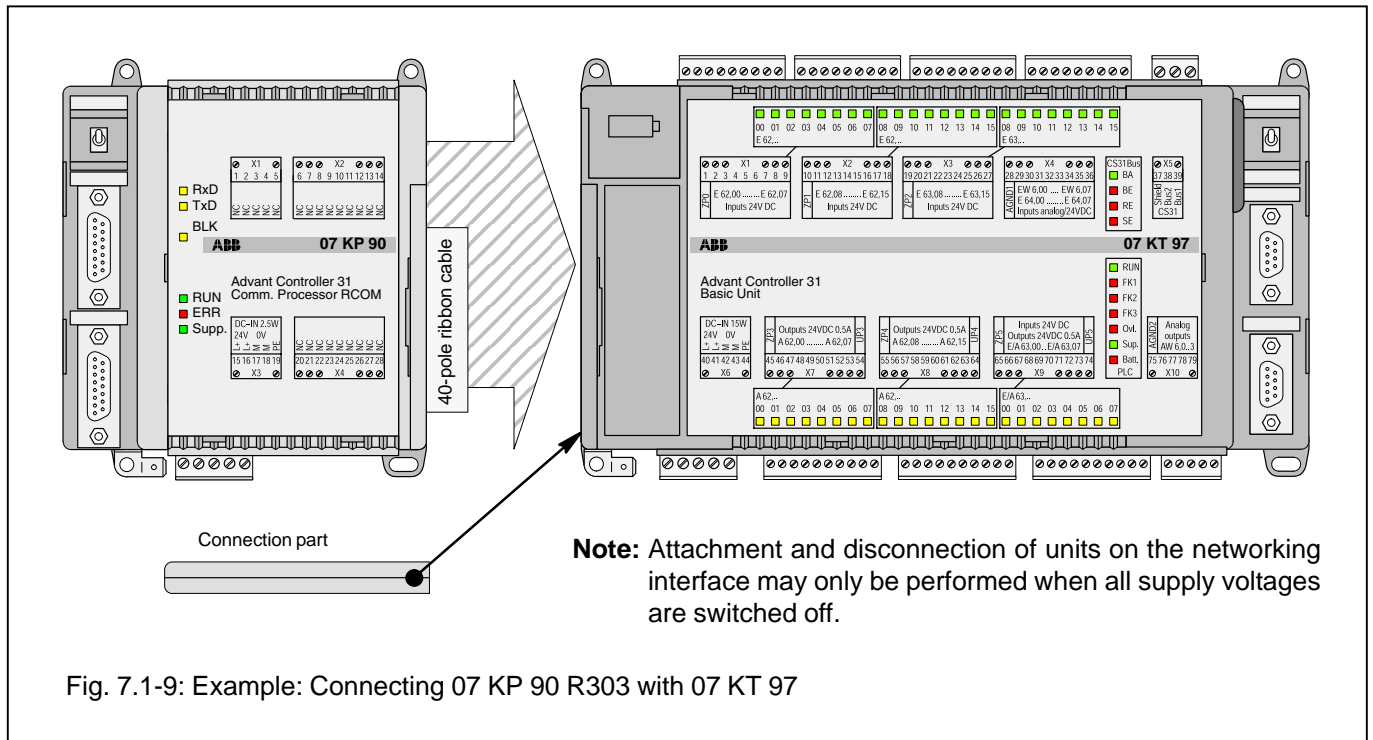

#### Mounting the expansion housing

1. Detach the cover on basic unit from the networking interface.
2. Plug the socket strip of the 40-pole ribbon cable secured to the 07 KP 90 R303 onto the networking connector of the basic unit.
3. Place both units on a level surface and slide them together so that they engage.
4. Slide in the connection part to fix the housing in position.

## 7.1.5 Diagnosis

### LED displays for RCOM system messages

⑨ yellow  
yellow  
yellow

RxD  
 TxD  
 BLK

RxD: 07 KP 90 is receiving an RCOM telegram.  
 TxD: 07 KP 90 is transmitting data via the RCOM interface.  
 BLK: Transmission of user data blocked as the result of communication error. After normalization LED 'BLK' goes out again.

Fig. 7.1-10: LED displays for RCOM system messages

### LED displays for RUN, ERR and Supply

⑩ green  
red  
green

RUN  
 ERR  
 Supply

RUN: 07 KP 90 is ready for RCOM communication (is running).  
 ERR: A RCOM communication error has occurred. In the case of recoverable errors, the LED goes out again after a short time. In the case of fatal errors, the LED remains ON continuously. The 'RUN' LED also goes out.  
 Supply: Supply voltage is present.

Fig. 7.1-11: LED displays for RUN, ERR and Supply

### Operating states, error displays

RUN gn	RxD ye	TxD ye	BLK ye	Supply gn	ERR rd	Meaning	Remedy
<input type="checkbox"/>	<input type="checkbox"/>	<input type="checkbox"/>	<input type="checkbox"/>	<input type="checkbox"/>	<input type="checkbox"/>	Supply voltage not present.	<ul style="list-style-type: none"> <li>Switch on supply voltage.</li> <li>Check supply voltage.</li> </ul>
<input type="checkbox"/>	<input type="checkbox"/>	<input type="checkbox"/>	<input type="checkbox"/>	☆	<input type="checkbox"/>	Supply voltage present. 07 KP 90 not ready for communication <ul style="list-style-type: none"> <li>during device reset or</li> <li>after fatal error.</li> </ul>	<ul style="list-style-type: none"> <li>Switch supply voltage of 07 KP 90 R303 and 07 KT 97 off and on again.</li> </ul>
☆	<input type="checkbox"/>	<input type="checkbox"/>	<input type="checkbox"/>	☆	<input type="checkbox"/>	07 KP 90 R303 is ready for communication.	--
☆	☆	<input type="checkbox"/>	<input type="checkbox"/>	☆	<input type="checkbox"/>	07 KP 90 R303 is receiving a data telegram.	--
☆	<input type="checkbox"/>	☆	<input type="checkbox"/>	☆	<input type="checkbox"/>	07 KP 90 R303 is transmitting a data telegram.	--
☆	X	X	<input type="checkbox"/>	☆	<input type="checkbox"/>	RCOM operation	--
☆	X	X	☆	☆	<input type="checkbox"/>	Transmission of user data not possible owing to the communication sequence.	<ul style="list-style-type: none"> <li>Normalization</li> </ul>
☆	X	X	<input type="checkbox"/>	☆	☆	RCOM communication error.	<ul style="list-style-type: none"> <li>The ERR LED goes out again automatically in the case of recoverable errors.</li> </ul>
<input type="checkbox"/>	<input type="checkbox"/>	<input type="checkbox"/>	<input type="checkbox"/>	☆	☆	Fatal RCOM communication error.	<ul style="list-style-type: none"> <li>Switch the supply voltage of 07 KP 90 and 07 KT 97 off and then on again.</li> </ul>
X	☆	☆	☆	X	☆	Hardware error, (RAM, EPROM, DP-RAM)	<ul style="list-style-type: none"> <li>Switch the supply voltage of 07 KP 90 and 07 KT 97 off and then on again.</li> </ul>

□ = LED off, ☆ = LED on, ✦ = LED flashes, X = LED on or off, ye = yellow, gn = green, rd = red

Fig. 7.1-12: Signalling operating states and error display



## 7.1.6 Technical data

In general, the details in section 1 "System data and system structure" of volume 2 of the system description "Advant Controller 31" apply as technical data. Supplementary and deviating data is listed below.

### 7.1.6.1 General data

Number of serial interfaces	2
Number of parallel interfaces	1 networking interface for connecting to the Advant Controller 31 basic unit
Operating and error displays	6 LEDs: RUN, ERR, Supply, RxD, TxD, BLK
Conductor cross section for the removable terminal blocks	max. 2.5 mm <sup>2</sup>

### 7.1.6.2 Power supply for 07 KP 90 R303

Rated supply voltage	24 V DC
Power dissipation	typ. 2.5 W
max. current consumption	
with rated voltage	210 mA
with a supply voltage of 30 V	170 mA
Protection against reversed terminal connection	yes

### 7.1.6.3 Serial interfaces RCOM and CONSOLE

Interface standard	EIA RS-232 or EIA RS-485 (RCOM only)
Electrical isolation	yes, RCOM interface with respect to the rest of the unit (see also Fig. 7.1-5)
Potential differences	So that no earthing potential differences arise between the 07 KP 90 R303 and the peripheral units connected to RCOM and CONSOLE, the latter are supplied from the switch-gear cabinet mains socket (also see earthing connections in Figure 7.1-5).
Transmission speed (Baud rate)	
RCOM	300...19200 Baud
CONSOLE	9600 Baud
Terminal assignment and description of the interfaces RCOM, CONSOLE	see page 7.1-8 onwards

### 7.1.6.4 LED displays

LEDs for operating and error displays:

– Supply voltage present (Supply)	1 green LED
– Fatal or serious error occurred (ERR)	1 red LED
– Ready for RCOM communication (running), (RUN)	1 green LED
– Interface signals RxD, TxD	2 yellow LEDs
– Protocol status BLK	1 yellow LED

**7.1.6.5 Mechanical data**

Mounting on DIN rail

in accordance with DIN EN 50022–35, 15 mm deep. The DIN rail is located in the middle between the upper and the lower edges of the module.

Fastening by screws

using 4 M4 screws.

Width x height x depth

140 x 120 x 85 mm

Wiring method

by removable terminal blocks with screw-type terminals, max. 2.5 mm<sup>2</sup>

Weight

450 g

Dimensions for mounting

see the following drawing

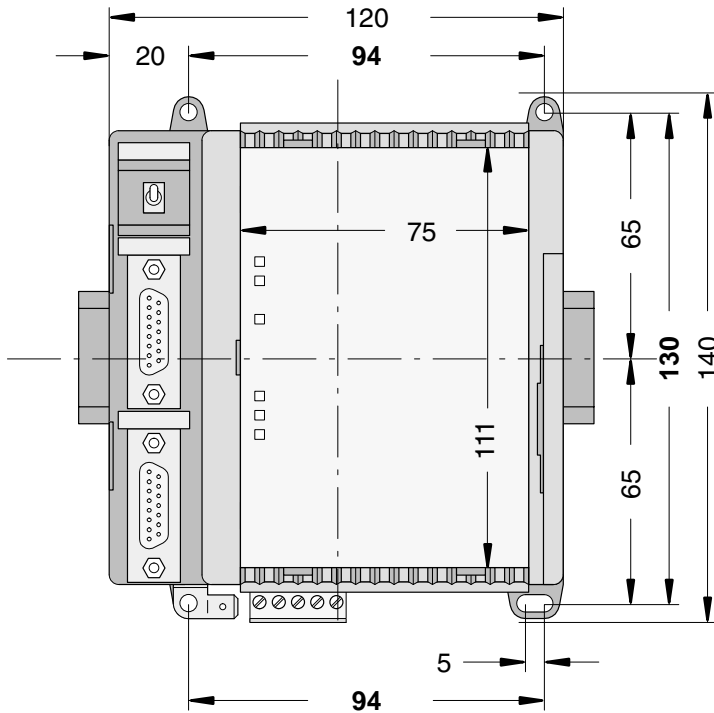

All dimensions in mm.

**The device is 85 mm deep.** The interface connectors RCOM and CONSOLE are set deeper so that the mounting depth required does not become any larger even with detachable interface cables. If, however, a DIN rail is used, the mounting depth is increased by the overall depth of the rail.

Fig. 7.1-13: Dimensions of the Communications module 07 KP 90 R303, front view, **the dimensions for assembly bore holes are printed in bold**

**7.1.6.6 Mounting hints**

Mounting position

vertical, terminals above and below

Cooling

The natural convection cooling must not be hindered by cable ducts or other material mounted in the switch-gear cabinet.

### 7.1.6.7 Ordering data

Communication module 07 KP 90 R303

Order No. GJR5 2510 00 R0303

Scope of delivery

Communication module 07 KP 90 R303  
1 5-pole terminal block (5.08 mm grid)  
Cable including terminals for making the  
earth connection  
Earthing instructions enclosed

### Further literature

System description Advant Controller 31, English

Order No. 1SAC 1316 99 R0201

System description ABB Procontic T200, English

Order No. GATS 1314 99 R2001

### Software

907 KP 90 R202, English documentation,  
CE library and example programs,

Order No. GJP5 2051 00 R0202 b

## 7.1.7 System cables and adaptors

### 7.1.7.1 CONSOLE to PC (25-pole) for commissioning

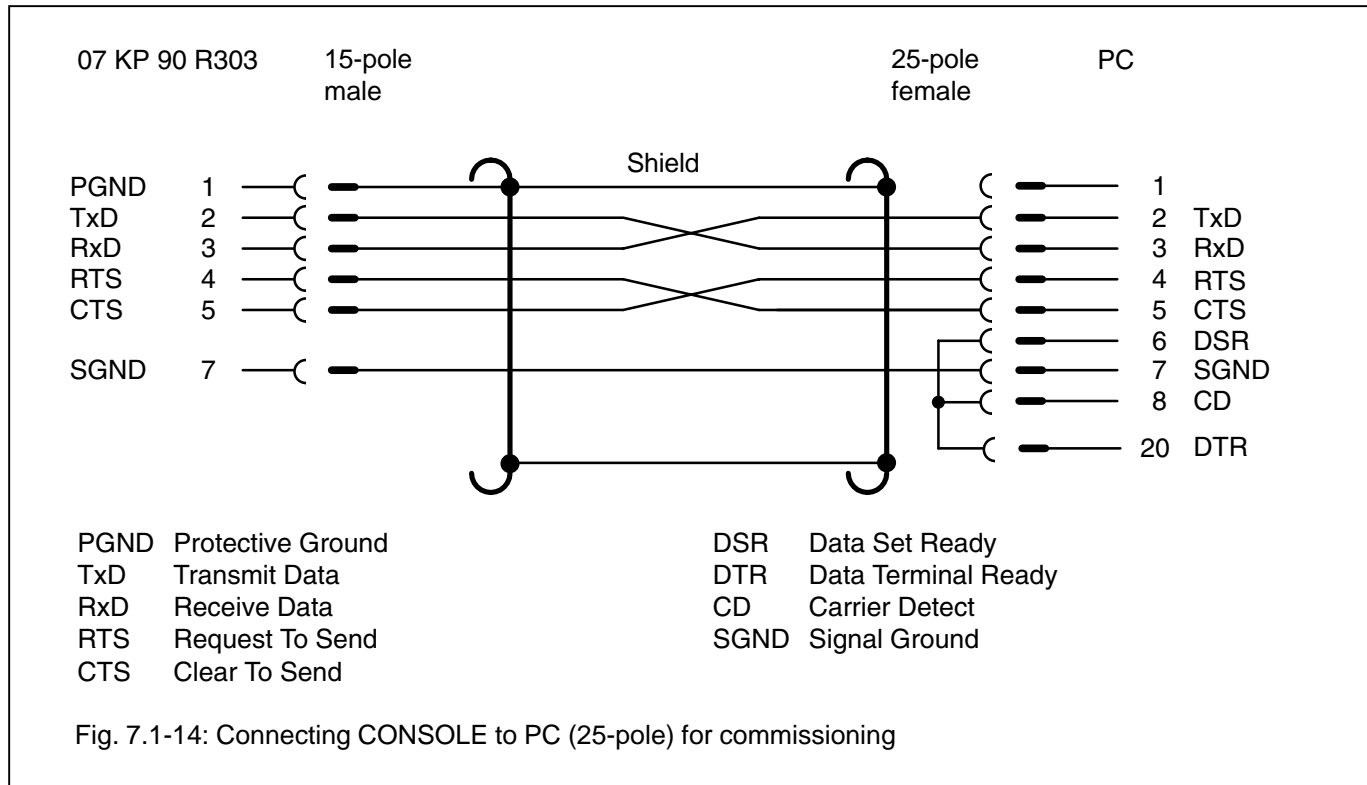

### 7.1.7.2 RCOM as EIA RS-232 to modem

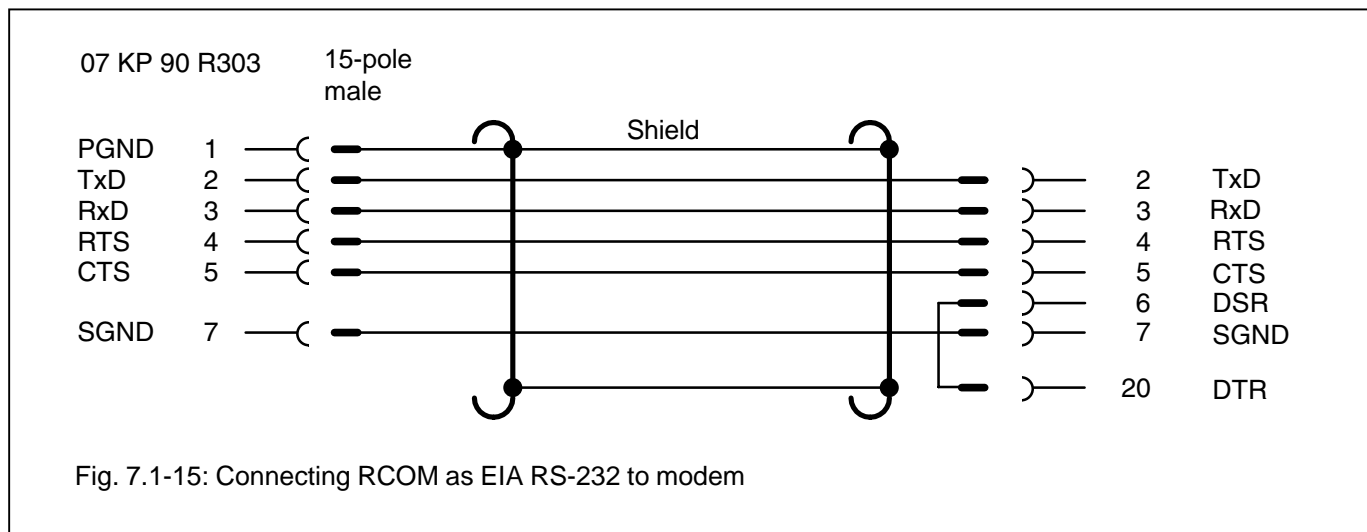

### 7.1.7.3 RCOM as EIA RS-485

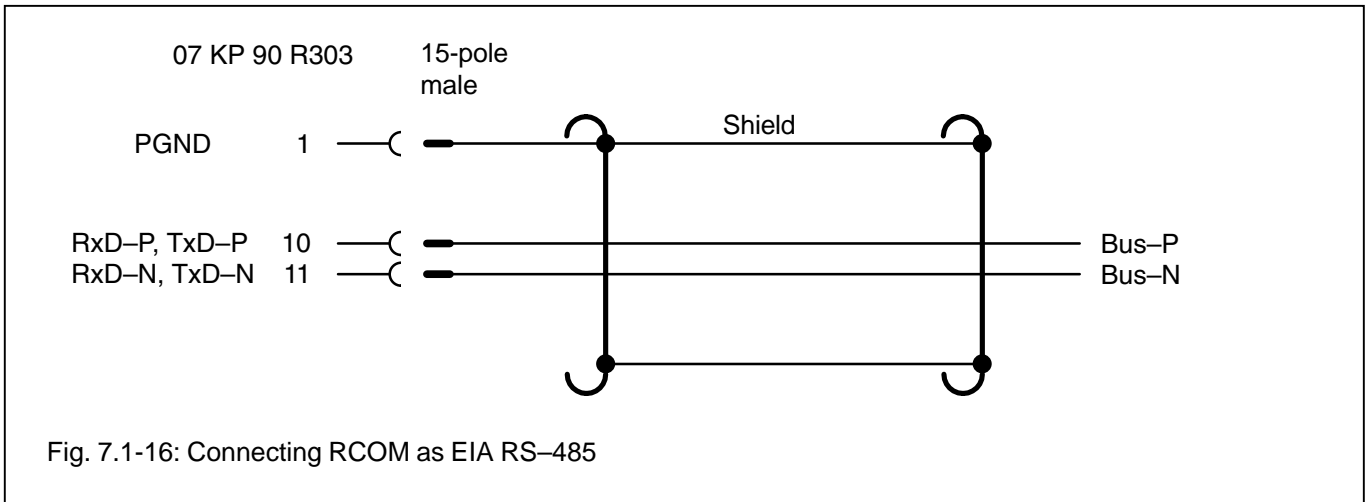

### 7.1.7.4 Adaptor 15-pole / 9-pole

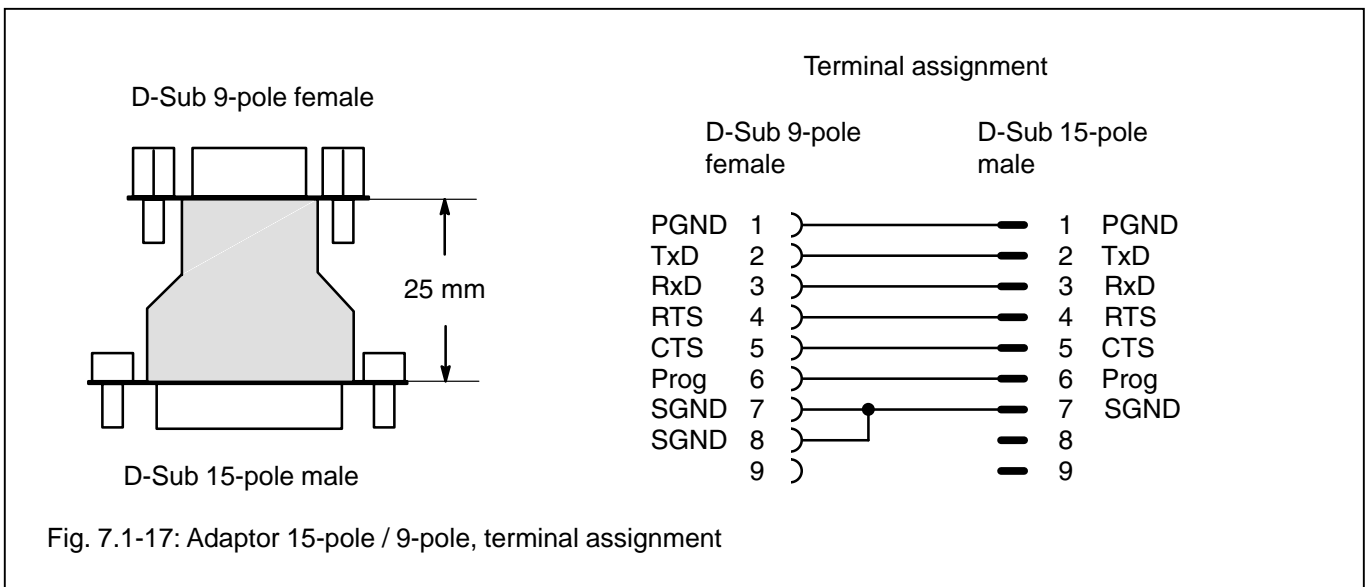



## 7.2 Communication module 07 MK 92 R1161 (no longer available) Connecting external units

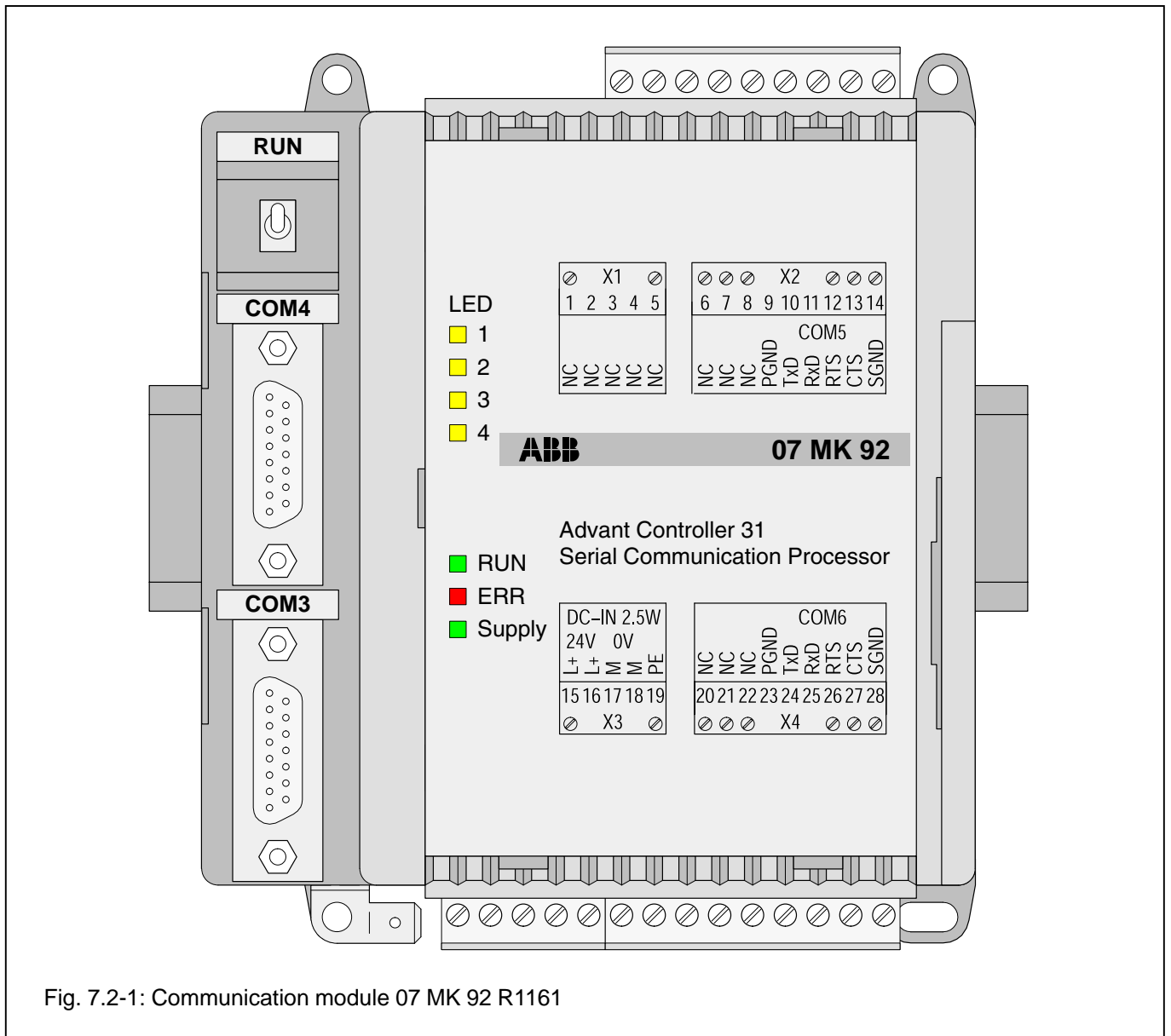

Fig. 7.2-1: Communication module 07 MK 92 R1161

### Contents

7.2.1	Brief description.....	7.2-1
7.2.2	Structure of the front panel elements .....	7.2-3
7.2.3	Electrical connection .....	7.2-4
7.2.3.1	Application example .....	7.2-4
7.2.3.2	Connecting the supply voltage .....	7.2-6
7.2.3.3	Electrical isolation and earthing instr. ....	7.2-6
7.2.3.4	Serial interfaces.....	7.2-8
7.2.3.5	Networking interface.....	7.2-11
7.2.4	Diagnosis .....	7.2-12
7.2.5	Programming and test software 907 MK 92 .....	7.2-12
7.2.6	Technical data .....	7.2-13
7.2.7	System cables .....	7.2-16
7.2.8	Memory areas in 07 MK 92 .....	7.2-19
7.2.9	LED control .....	7.2-19
7.2.10	Allocation of the ports .....	7.2-19

### 7.2.1 Brief description

The 07 MK 92 R1161 communication module is a freely programmable interface module with 4 serial interfaces.

The communication module allows external units to be connected to the Advant Controller 31 system via a serial interface.

The communications protocols and transmission types can be freely defined by the user.

Programming is performed on a PC with the programming and test software 907 MK 92.

The communication module is connected to AC31 basic units via the networking interface, e.g. 07 KR 91 R353, 07 KT 92 (index i onwards) 07 KT 93 or 07 KT 94.

The most important features of the communication module are:

- 4 serial interfaces:
  - 2 of them are serial interfaces, optionally configurable in accordance with EIA RS-232 or EIA RS-422 or EIA RS-485 (COM3, COM4)
  - 2 of them are interfaces in accordance with EIA RS-232 (COM5, COM6)
- Freely programmable with a comprehensive function library
- Communication with AC31 basic unit via library functions
- Configurable LEDs for diagnosis
- Programming and testing on a PC via COM3

Processing of the serial interfaces and the networking interface is provided for in an applications program.

Programming is in the standard language "C".

The exchange of data between the serial communication module and the AC31 basic unit is realized by function blocks in the basic unit.



## 7.2.2 Structure of the front panel elements

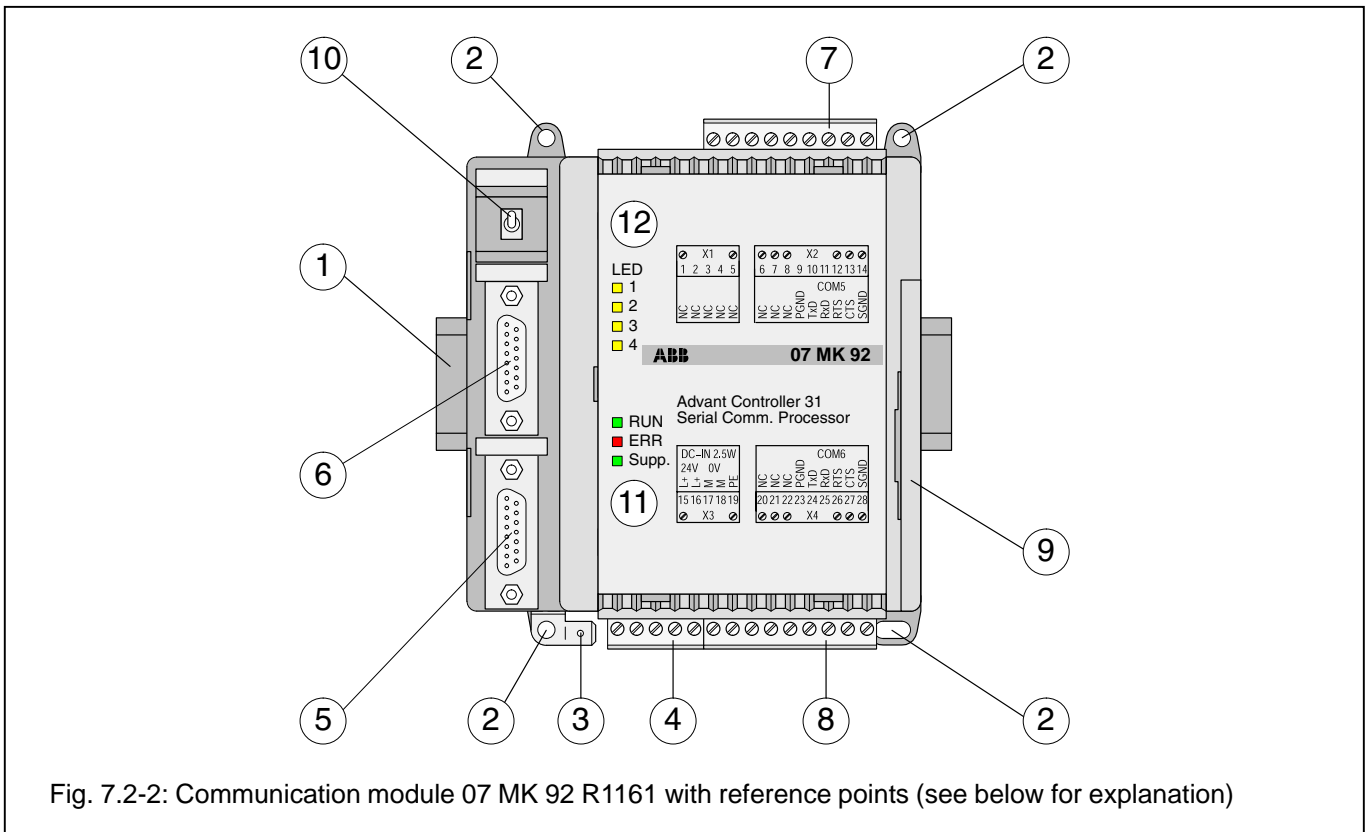

- 1 Mounting the unit on a DIN rail
- 2 Mounting the unit with screws
- 3 6.3 mm Faston earthing terminal
- 4 24 V DC supply voltage
- 5 Configurable serial interface COM3
- 6 Configurable serial interface COM4
- 7 Serial interface COM5
- 8 Serial interface COM6
- 9 Networking interface for the Advant Controller 31 basic unit
- 10 Switch for RUN/STOP operation

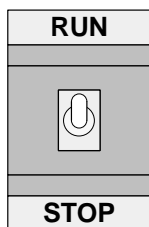

The RUN/STOP switch controls the processing of the user application.

### STOP → RUN

If the switch is switched from STOP to RUN, the user application is loaded into the main memory and processing of the application program is started.

The status of the application program is indicated by the LED RUN: The LED RUN lights up while the program is being processed. If an error occurred during loading (e.g. program not present), the LED RUN remains OFF.

### RUN → STOP

If the switch is switched from RUN to STOP, the program processing is aborted. The LED RUN goes out.

### 11 LED displays for system messages

### 12 LED displays freely configurable

- ⑫  
yellow  
yellow  
yellow  
yellow

- LED1
- LED2
- LED3
- LED4

- ⑪  
green  
red  
green

- RUN
- ERR
- Supply

Application program is running  
Fatal or serious error  
Supply voltage present

Refer to Section 7.2.4 Diagnosis for further information

## 7.2.3 Electrical connection

### 7.2.3.1 Application example for connecting the inputs and outputs

The following illustration shows an application example with the 07 KT 97 which utilizes various possibilities for connecting inputs and outputs. Attention must be paid to the following in detail:

- The earthing measures
- Connection of the 07 MK 92 communication module
- Looping through the supply voltage (24 V DC) from the 07 KT 97 to the 07 MK 92
- Earthing the switch-gear cabinet mains socket
- Handling serial interfaces

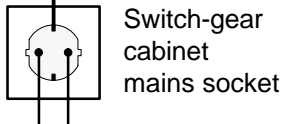
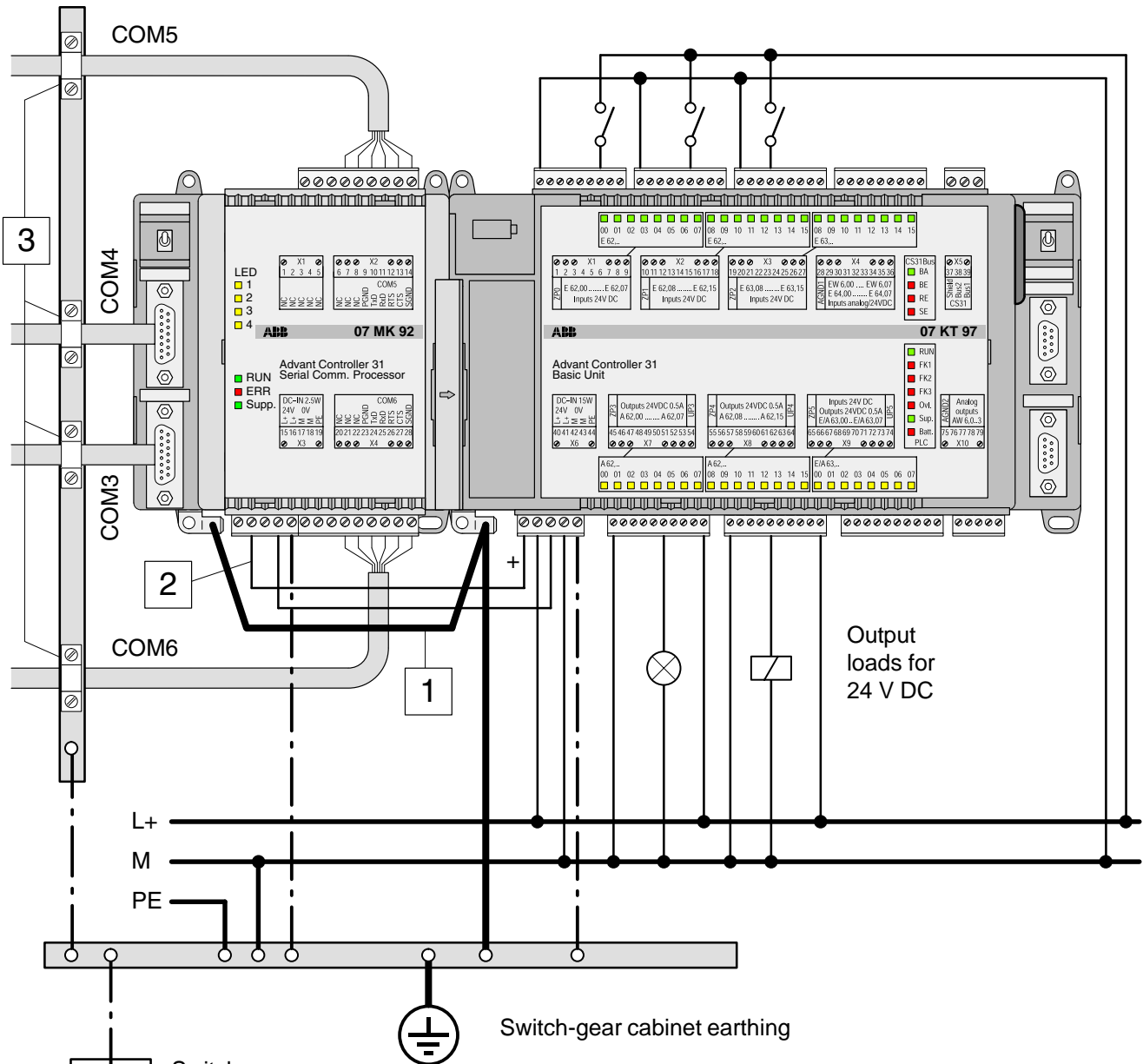

1

2

3

Switch-gear cabinet earthing

Earth connection:  
Use supplied parts (see Figure 7.2-6)

Supply voltage:  
Short, direct connection between the modules,  
wires 15 cm, 2.5 mm<sup>2</sup> (see Figure 7.2-6)

Cable shields:  
In the case of permanent wiring at the switchgear cabinet inlet, earth via clamps and do not put shield in the plug. Otherwise, lay the cable shield in the plug to PGND.

Fig. 7.2-3: Application example:  
Communication module 07 MK 92 at basic unit 07 KT 97  
(Section 7.2.3 Electrical connection applies in the same way to 07 KR 91, 07 KT 92 to 07 KT 97.)

### 7.2.3.2 Connecting the 24 V DC supply voltage

The supply voltage is fed in via a 5-pole detachable terminal block.

**Important:**

**Plug and unplug terminal block only with power off!**

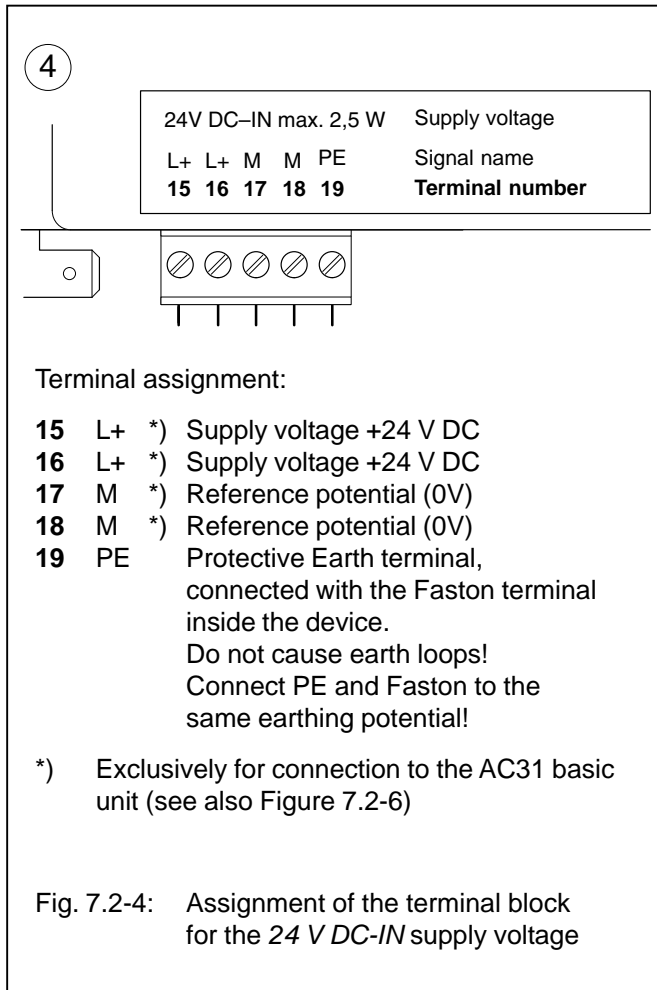

Fig. 7.2-4: Assignment of the terminal block for the 24 V DC-IN supply voltage

### 7.2.3.3 Electrical isolation and notes on earthing

The following illustration shows which circuit parts of the unit are electrically isolated from each other and which internal connections exist. Here, both the clearances and creepage distances and also the test voltages used correspond to DIN/VDE 0160.

The unit is connected via the 6.3 mm Faston terminal (bottom left) to the functional earth (switch-gear cabinet earth) via a wire with a cross section of 6 mm<sup>2</sup> (also see Fig. 7.2-6).

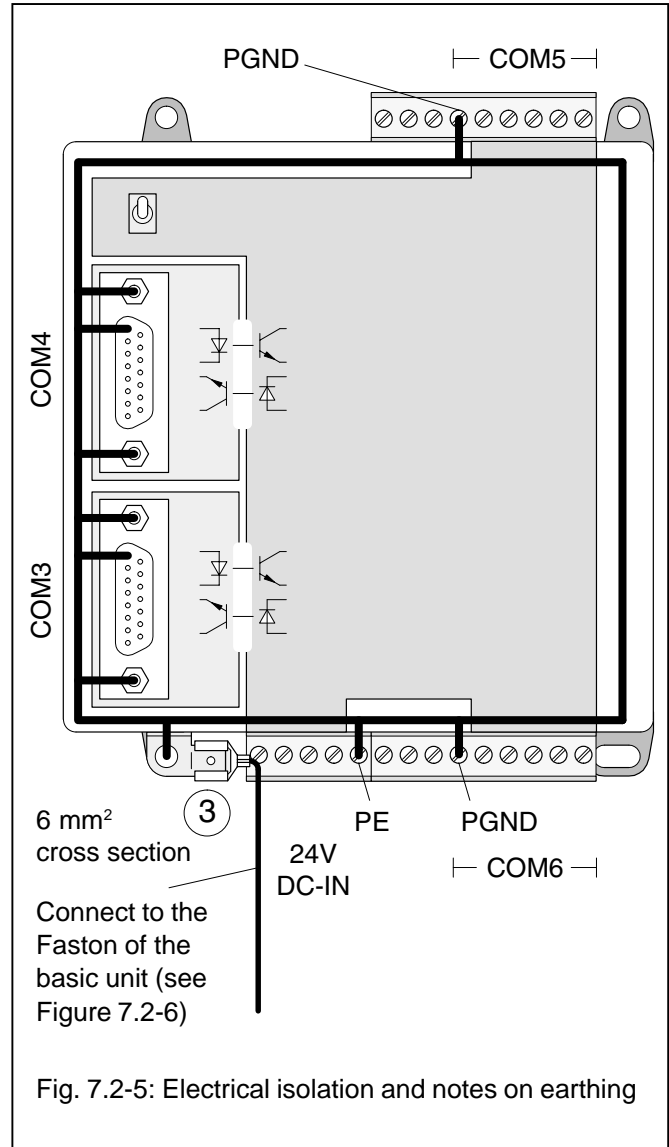

Fig. 7.2-5: Electrical isolation and notes on earthing

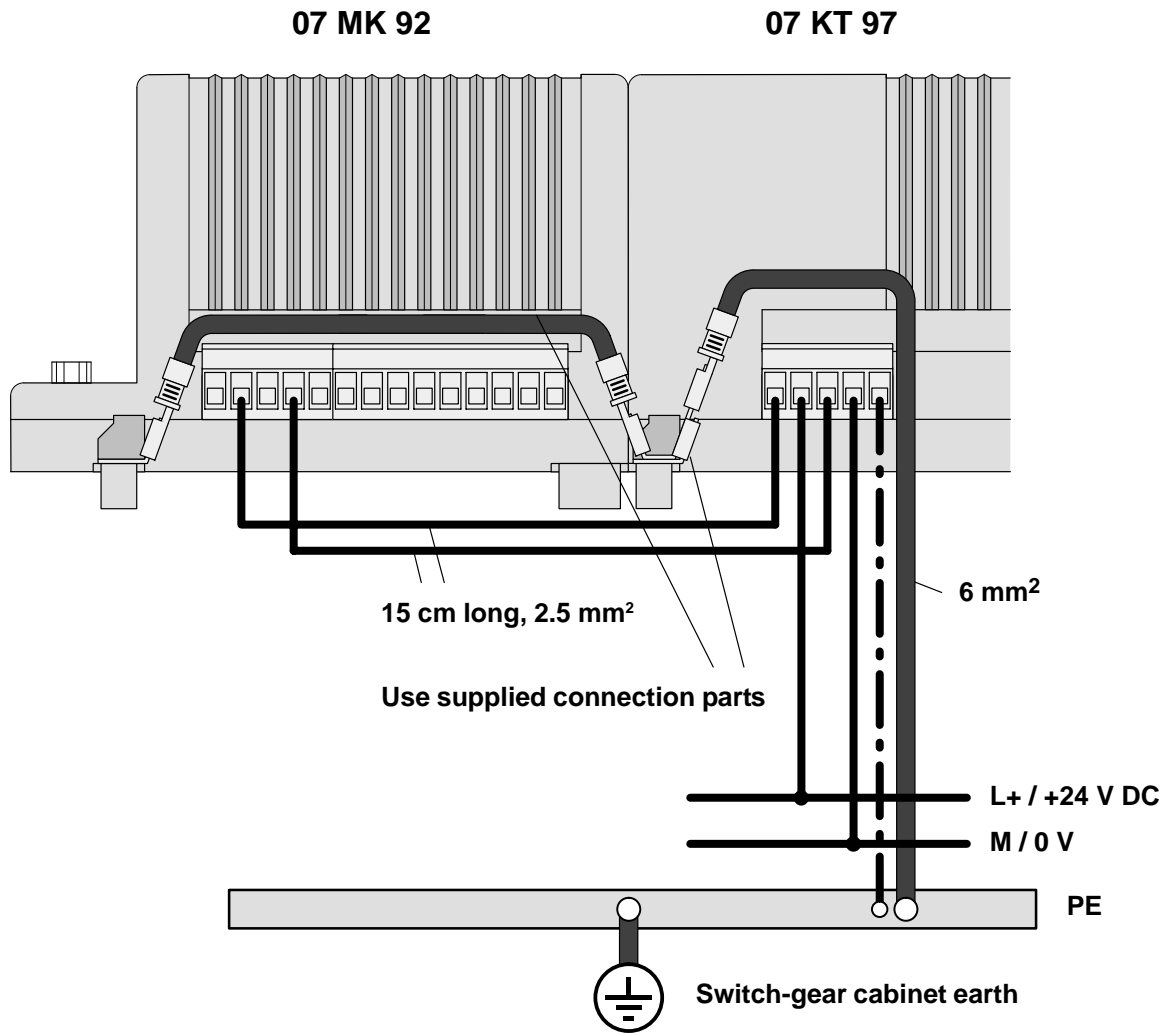

Fig. 7.2-6: Earthing connections and voltage supply for 07 MK 92

### 7.2.3.4 Serial interfaces

#### Use

External units can be connected to the AC31 system via the serial interfaces. The interfaces are independent of each other. They can be managed via freely definable protocols.

#### Scope of functions

The four serial interfaces can be configured independently of each other in the following scope of functions:

- Data format 7 or 8 bits
- Even, odd or no parity
- Discrete baud rates  
from 300 Bd to 19200 Bd for COM3 and COM 4 and  
from 300 Bd to 9600 Bd for COM5 and COM6
- Automatic processing of the SW handshake  
(XON/XOFF)
- Automatic processing of the HW handshake  
(RTS/CTS)
- Error detection  
(parity, framing, overrun, break)

### Serial interfaces COM3, COM4

#### Interface standard

- EIA RS-232 or
- EIA RS-422 or
- EIA RS-485

Both interfaces can be run independently of each other in one of the interface standards each. Selection is by choosing the corresponding interface signals.

#### Modes

- Programming and test mode
- Application mode

COM3 can be used as a programming and test interface.

#### Electrical isolation

Both interfaces are electrically isolated.

#### Connection

Connection is via a 15-pole D-SUB connector (female).

### Serial interface COM3: Terminal assignment

Interface standard: EIA RS-232, EIA RS-422, EIA RS-485

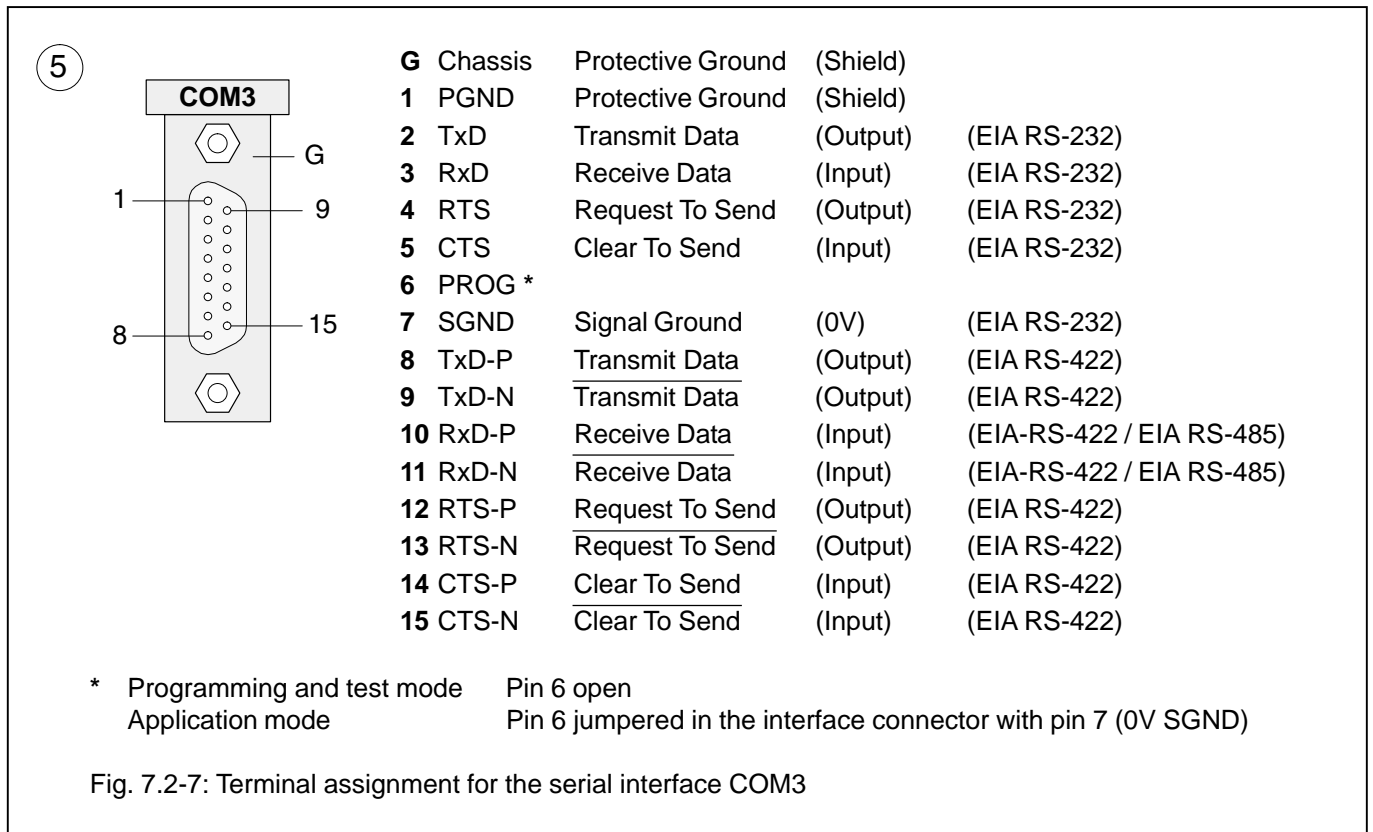

### Serial interface COM4: Terminal assignment

Interface standard: EIA RS-232, EIA RS-422, EIA RS-485

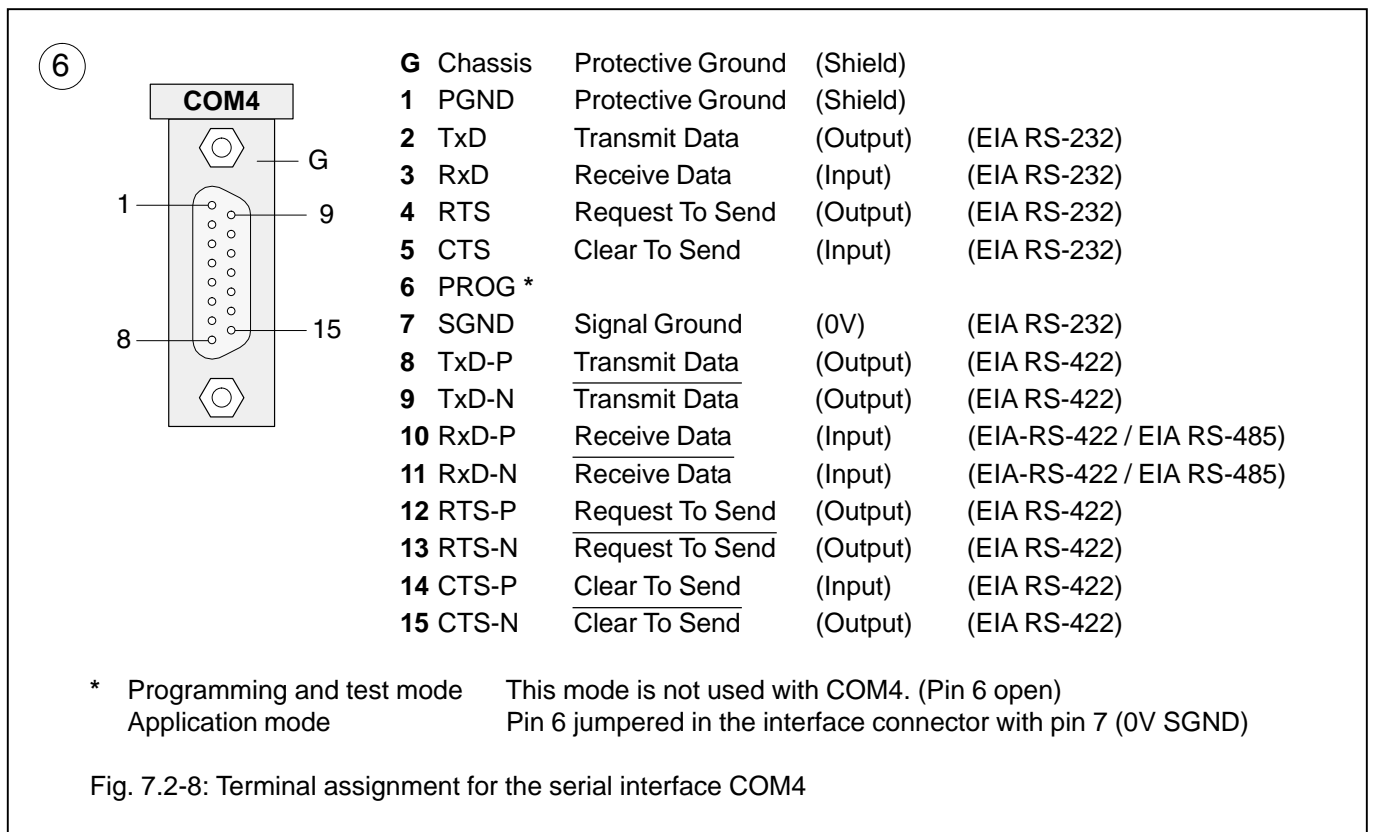

## Serial interfaces COM5, COM6

### Interface standard

EIA RS-232

### Mode

Application mode

### Electrical isolation

Both interfaces are not electrically isolated.

### Connection

Connection is via removable screw-type terminal blocks.

### Serial interface COM5: Terminal assignment

Interface standard: EIA RS-232

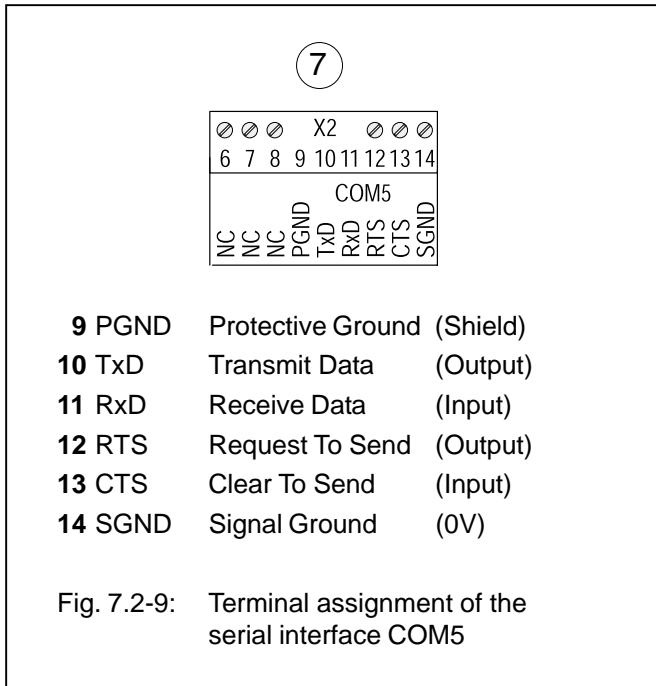

### Serial interface COM6: Terminal assignment

Interface standard: EIA RS-232

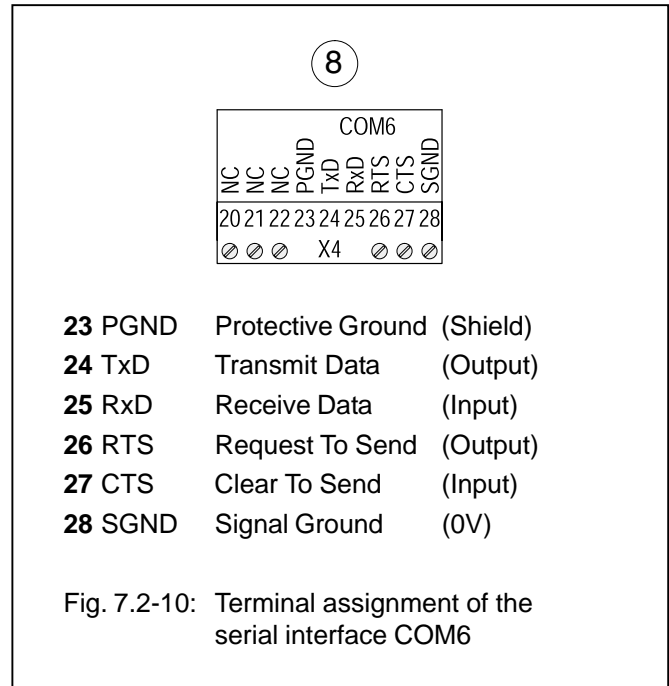



### 7.2.3.5 Networking interface 9

The networking interface, a special parallel interface, allows the 07 MK 92 communication module to be connected to AC31 basic units (such as 07 KR 91 R353, 07 KT 92 to 07 KT 97). The housing of the communication module is

connected to the housing of the AC31 basic unit by a snap-fit connection. The electrical connection is via a 40-pole ribbon cable with socket connector, soldered onto the 07 MK 92 side.

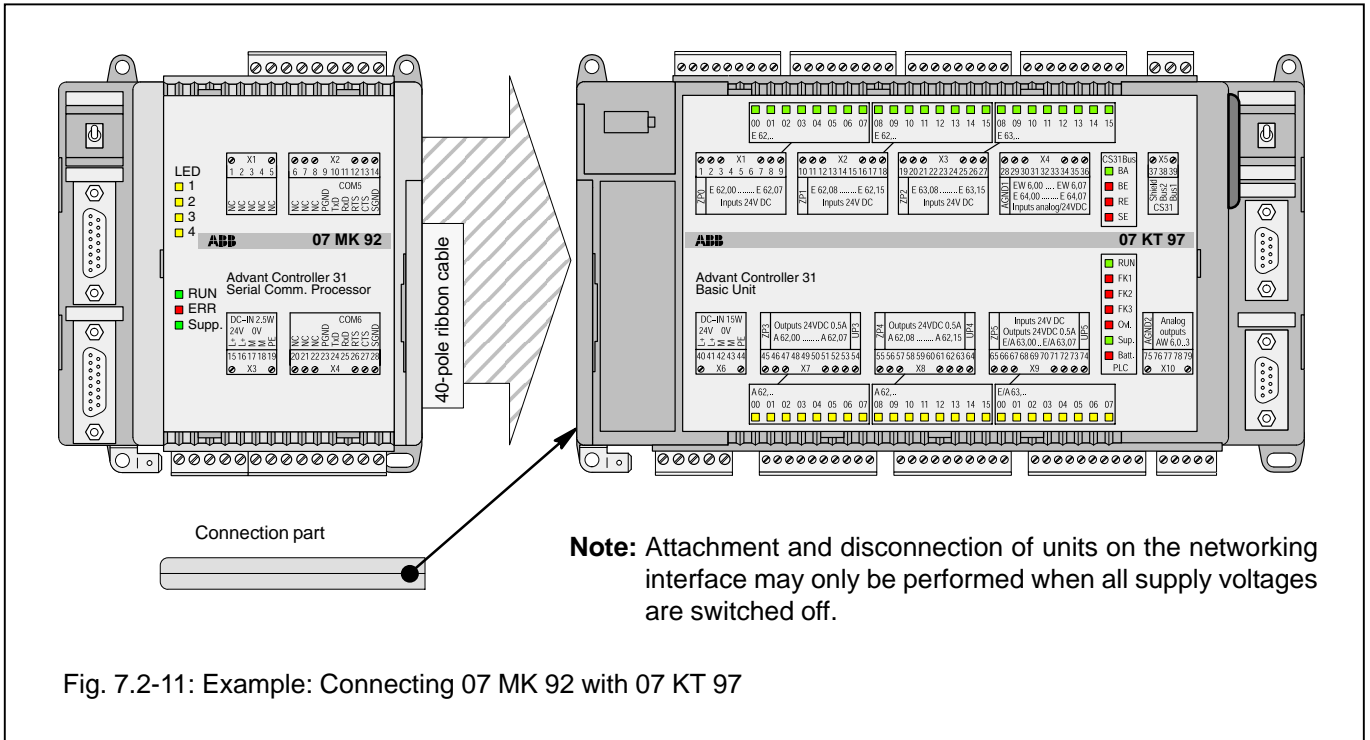

Fig. 7.2-11: Example: Connecting 07 MK 92 with 07 KT 97

#### Mounting the expansion housing

1. Detach the cover on the basic unit from the networking interface.
2. Plug the socket strip of the 40-pole ribbon cable secured to the 07 MK 92 onto the networking connector of the basic unit.
3. Place both units on a level surface and slide them together so that they engage.
4. Slide in the connection part to fix the housing in position.

## 7.2.4 Diagnosis

### LED displays for system messages RUN, ERR, Supply

11

green

red

green

RUN

ERR

Supply

The green LED "RUN" lights up when the user application is being processed.

The red LED "ERR" lights up when a fatal error (RAM error, DP-RAM error, EPROM error, Flash EPROM error) or a serious error is present.

The green LED "Supply" indicates the presence of the supply voltage.

Fig. 7.2-12: LED displays for system messages RUN, ERR, Supply

### LED displays, freely configurable

The yellow LEDs "LED1...LED4" are configurable. They can be controlled by the application program.

12

yellow

yellow

yellow

yellow

LED1

LED2

LED3

LED4

Fig. 7.2-13: LED displays, freely configurable

### Operating states, error display

RUN ERR Supply gn rd gn	Meaning	Remedy
■ ■ ■	Supply voltage not present.	<ul style="list-style-type: none"> <li>● Switch on supply voltage.</li> <li>● Check supply voltage.</li> </ul>
■ ■ ★	Supply voltage present. 07 MK 92 is ready to process the user application. <ul style="list-style-type: none"> <li>– Load user application with 907 MK 92.</li> <li>– Start processing of application: Switch RUN/STOP switch to RUN.</li> </ul>	
★ ■ ★	The user application is running.	
X ★ ★	A serious error is present which caused the user application to abort automatically.	<ul style="list-style-type: none"> <li>● Read out error and remedy if this is possible.</li> </ul>
★ ★ ★	Initialization procedure. Voltage ON.	
■ = LED off, ★ = LED on, X = LED on or off, gn = green, rd = red		

Fig. 7.2-14: Signalling operating states and error display

## 7.2.5 Programming and test software 907 MK 92

The communication module is programmed with the programming and test software 907 MK 92. This software can be run on an IBM-compatible PC. The PC is connected with the COM3 interface of the communication module.

In addition to the programming and test software, the package 907 MK 92 contains documentation of the communication module 07 MK 92 and configuration examples.

## 7.2.6 Technical data

In general, the details in section 1 "System data and system structure" of volume 2 of the system description "Advant Controller 31" apply as technical data. Supplementary and deviating data is listed below.

### 7.2.6.1 General data

Number of serial interfaces	4
Number of parallel interfaces	1 networking interface for connecting to the Advant Controller 31 basic unit
Built-in application software memory	Flash EPROM 128 kbytes
Diagnosis	4 configurable LEDs: LED1...4 (controlled by the application program)
Operating and error displays	3 LEDs: RUN, ERR, Supply
Conductor cross section for the removable terminals	max. 2.5 mm <sup>2</sup>

### 7.2.6.2 Supply voltage for 07 MK 92 R1161

Rated supply voltage	24 V DC
Power dissipation	typ. 2.5 W
Max. current consumption with rated voltage	210 mA
with supply voltage 30 V	170 mA
Protection against reversed terminal connection	yes (only when units with electrically isolated interfaces are connected to COM5/COM6)

### 7.2.6.3 Connection of serial interfaces COM3, COM4

Interface standard	EIA RS-232 or EIA RS-422 or EIA RS-485
Programming with 907 MK 92	via IBM-PC (or compatible)
Man-machine communication	yes, e.g. with an operating station
Electrical isolation	yes, interfaces with respect to each other and with respect to the rest of the unit (also see Figure 7.2-5)
Potential differences	So that no earthing potential differences arise between the 07 MK 92 and the peripheral units connected to COM3 and COM4, the latter are supplied from the switch-gear cabinet mains socket (also see earthing connections in Figure 7.2-5).
Terminal assignment and description of the interfaces COM3, COM4	see page 7.2-7 onwards

### 7.2.6.4 Connection of serial interfaces COM5, COM6

Interface standard	EIA RS-232
Man-machine communication	yes, e.g. with an operating station
Electrical isolation	none
Potential differences	see COM3, COM4
Terminal assignment and description of the interfaces COM5, COM6	see page 7.2-9 onwards

### 7.2.6.5 LED displays

LEDs for operating and error displays:

- Supply voltage present (Supply) 1 green LED
- Fatal or serious error occurred (ERR) 1 red LED
- Application program processing running (RUN) 1 green LED

Configurable LEDs for diagnosis: LED1...LED4 4 yellow LEDs

### 7.2.6.6 Mechanical data

Mounting on DIN rail

in accordance with DIN EN 50022–35, 15 mm deep.  
The DIN rail is located in the middle between the upper and the lower edges of the module.

Fastening by screws

using 4 M4 screws.

Width x height x depth

140 x 120 x 85 mm

Wiring method

by removeable terminal blocks with screw-type terminals, max. 2.5 mm<sup>2</sup>

Weight

450 g

Dimensions for mounting

see the following drawing

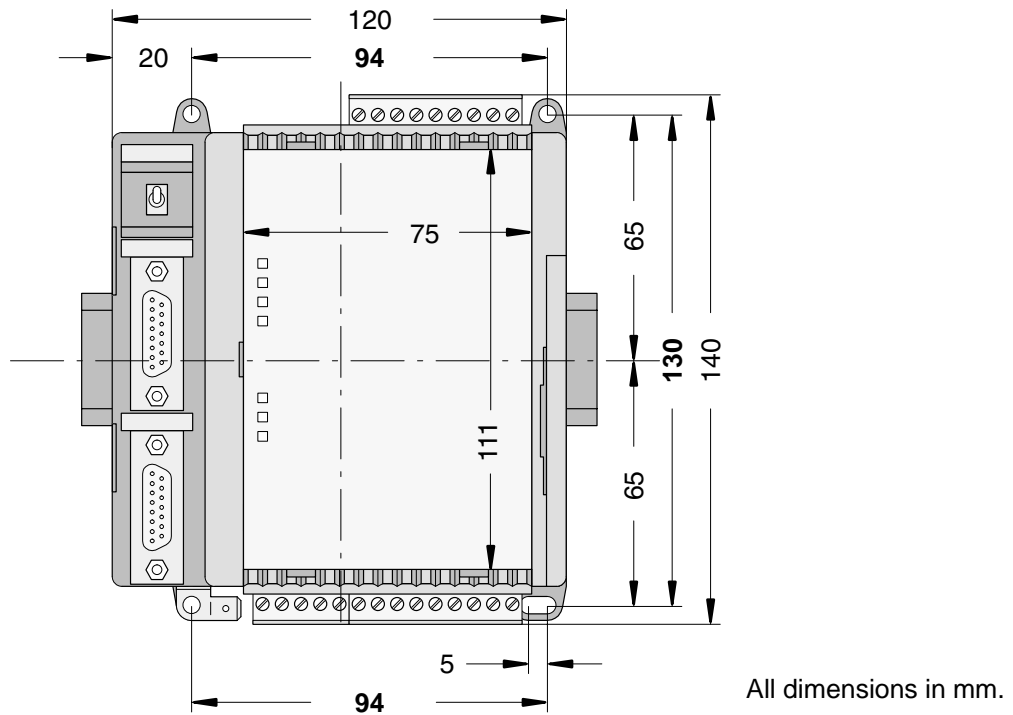

**The device is 85 mm deep.** The interface connectors COM3 and COM4 are set deeper so that the mounting depth required does not become any larger even with detachable interface cables. If, however, a DIN rail is used, the mounting depth is increased by the overall depth of the rail.

Fig. 7.2-15: Dimensions of the communication module 07 MK 92, front view, **the dimensions for assembly bore holes are printed in bold**

### 7.2.6.7 Mounting hints

Mounting position

vertical, terminals above and below

Cooling

The natural convection cooling must not be hindered by cable ducts or other material mounted in the switch-gear cabinet.

### 7.2.6.8 Ordering data

Communication module 07 MK 92 R1161

Order No. GJR5 2533 00 R1161 (no longer available)

Scope of delivery

Communication module 07 MK 92 R1161  
2 9-pole terminal blocks (5.08 mm grid)  
1 5-pole terminal block (5.08 mm grid)  
Cable including terminals for making the  
earth connection

### Further literature

System description Advant Controller 31, English

Order No. 1SAC 1316 99 R 0201

### Software

Programming and test software 907 MK 92

Order No. GJP5 2074 00 R0102

907 MK 92 consists of:

- Documentation
- Software
  - Basic functions for 07 MK 92 R1161
  - Paradigm Locate V 3.21

## 7.2.7 System cables

### 7.2.7.1 COM3 to PC (25-pole) for programming und test software 907 MK 92

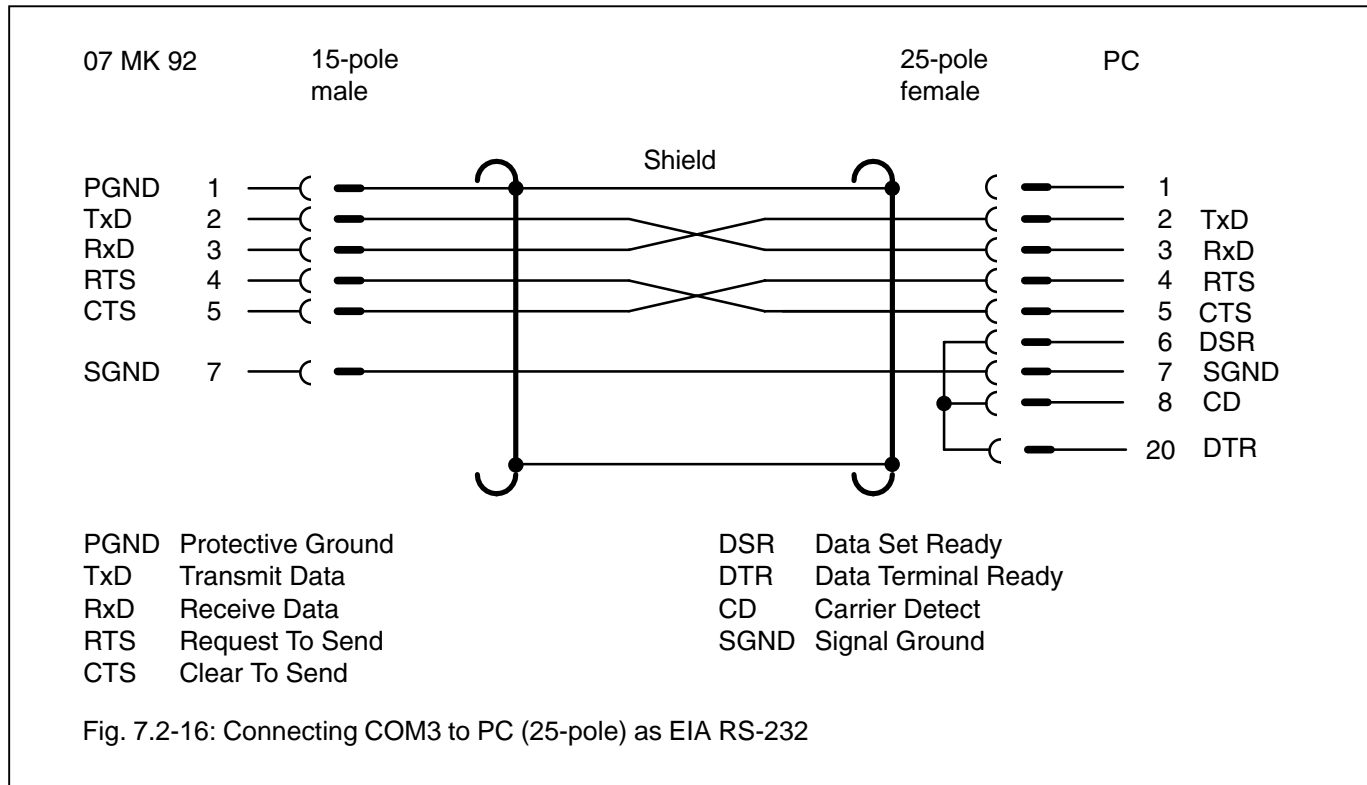

### 7.2.7.2 COM3 to PC (9-pole) for programming and test software 907 MK 92

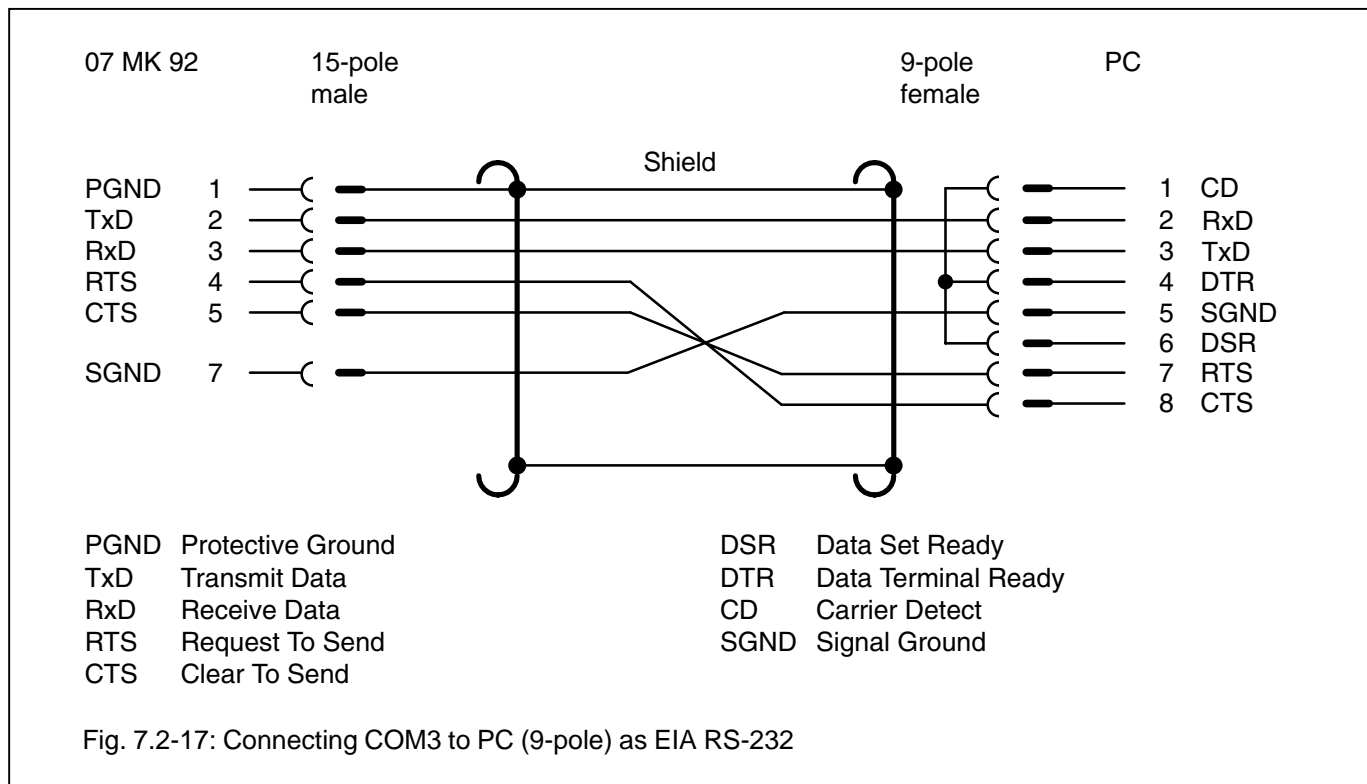

### 7.2.7.3 COM3, COM4 as EIA RS-232 interface

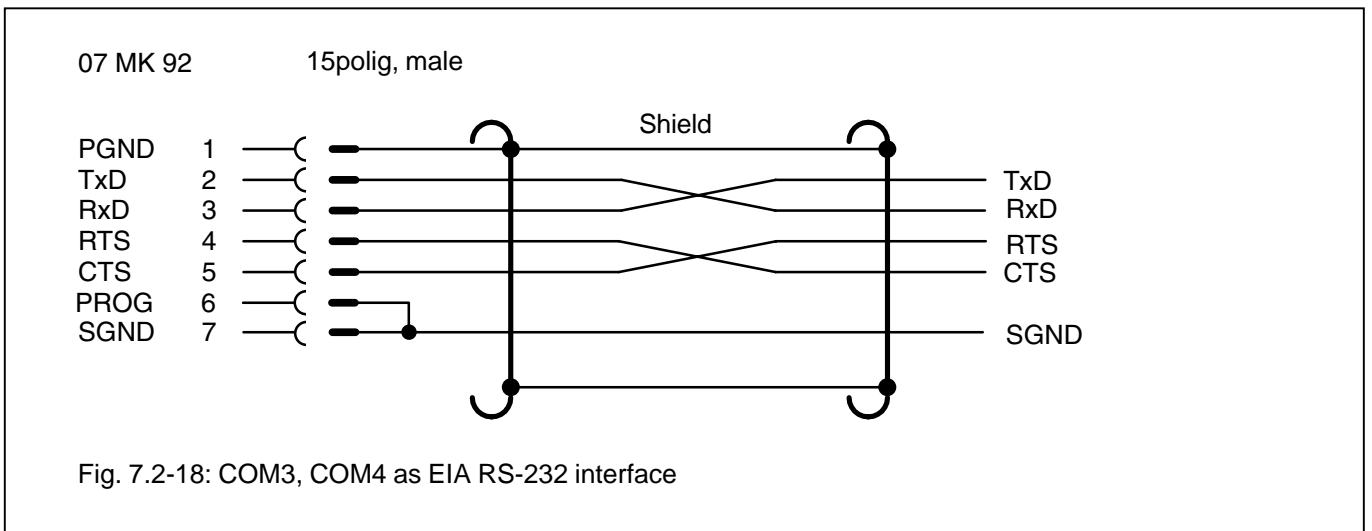

### 7.2.7.4 COM3, COM4 as EIA RS-422 interface

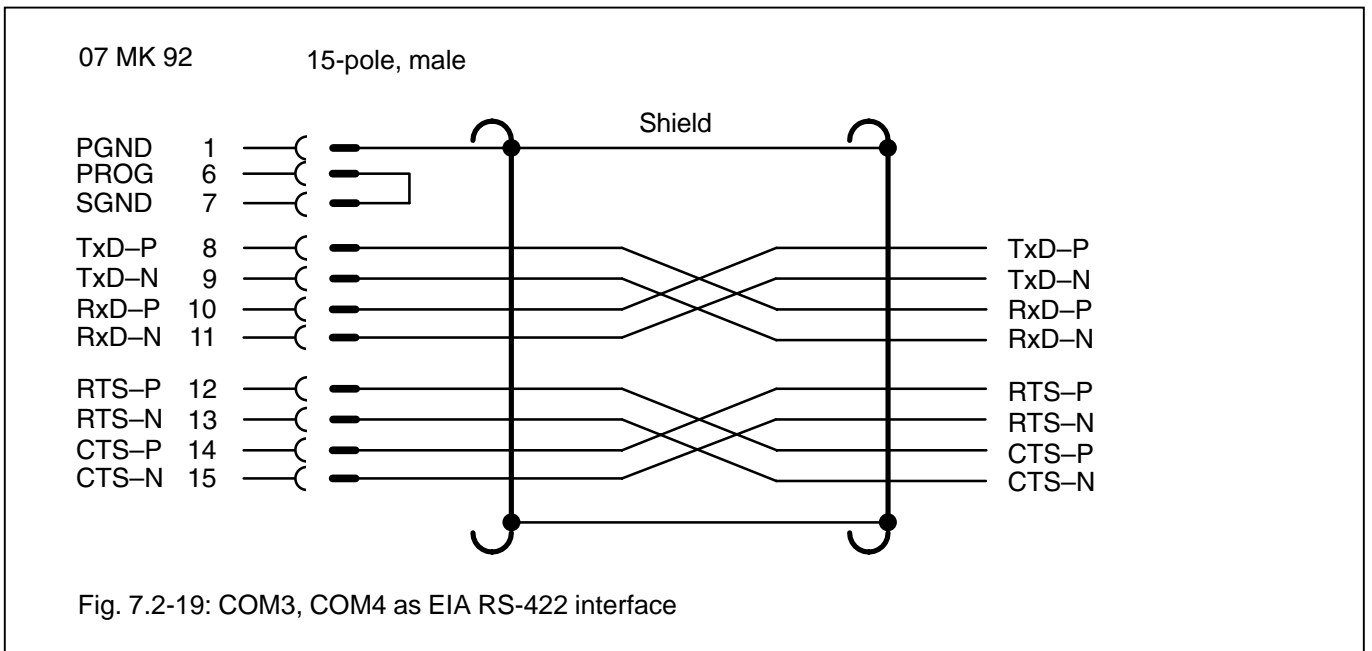

### 7.2.7.5 COM3, COM4 as EIA RS-485 interface

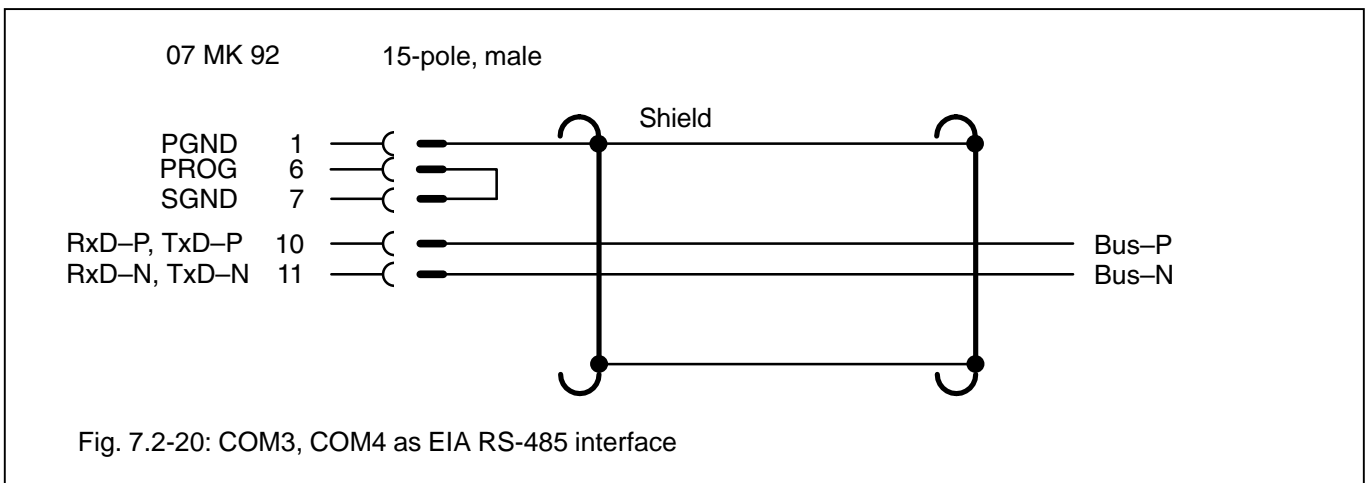

### 7.2.7.6 COM5 as EIA RS-232 interface

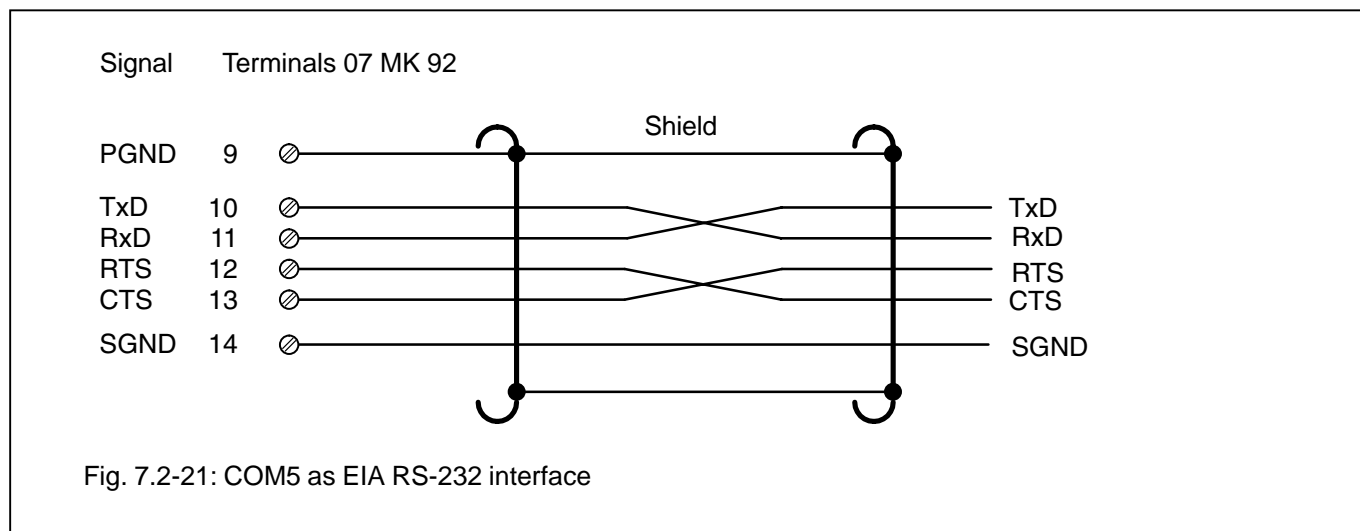

### 7.2.7.7 COM6 as EIA RS-232 interface

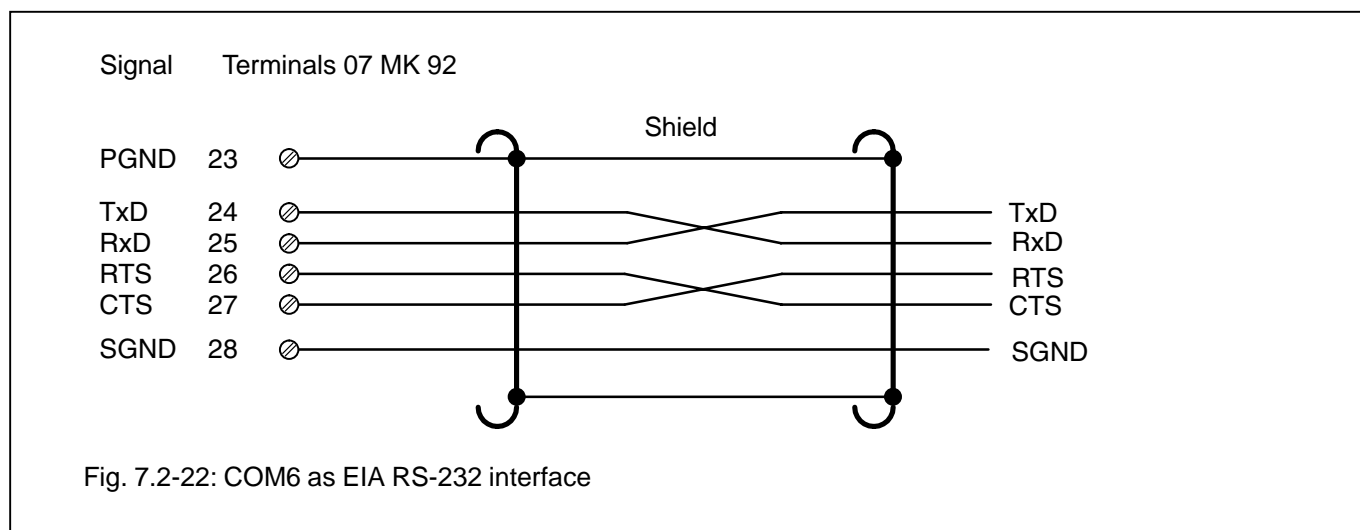



## 7.2.8 Memory areas in 07 MK 92

Used EPROM area	FFFFF (128 kB EPROM) FE000
Free EPROM area	FDFFF E0000
Not used	DFFFF C0000
Flash EPROM	BFFFF (128 kB) A0000
Not used	9FFFF 99000
LEDs	98FFF 98000
Not used	97FFF 90800
Dual Port RAM	907FF (2 kB) 90000
Not used	8FFFF 80000
Free RAM area	7FFFF (512 kB RAM) 00B00
Used RAM area	00AFF 00000

## 7.2.9 LED control

Addressing:	Segment:	9800	
	Offset:	0	LED1
		1	LED2
		2	LED3
		3	LED4
		4	LED RUN
(Flash programming voltage		5	EEPROM - Vpp)
		6	LED ERR

## 7.2.10 Allocation of the ports

Port P2PIN	Bit 5	RUN / STOP (1 = STOP, 0 = RUN)
Port P2PIN	Bit 6	Status of pin 6 at COM3
Port P2PIN	Bit 7	Status of pin 6 at COM4
Port P1LTCH	Bit 5	Control of RTS COM3
Port P1LTCH	Bit 7	RS-485 change-over COM3
Port P1LTCH	Bit 3	Control of RTS COM4
Port P1LTCH	Bit 6	RS-485 change-over COM4

The addresses of the ports are listed in the file MK92HW.H



## 7.3 Communication processor 07 KP 93 R1161

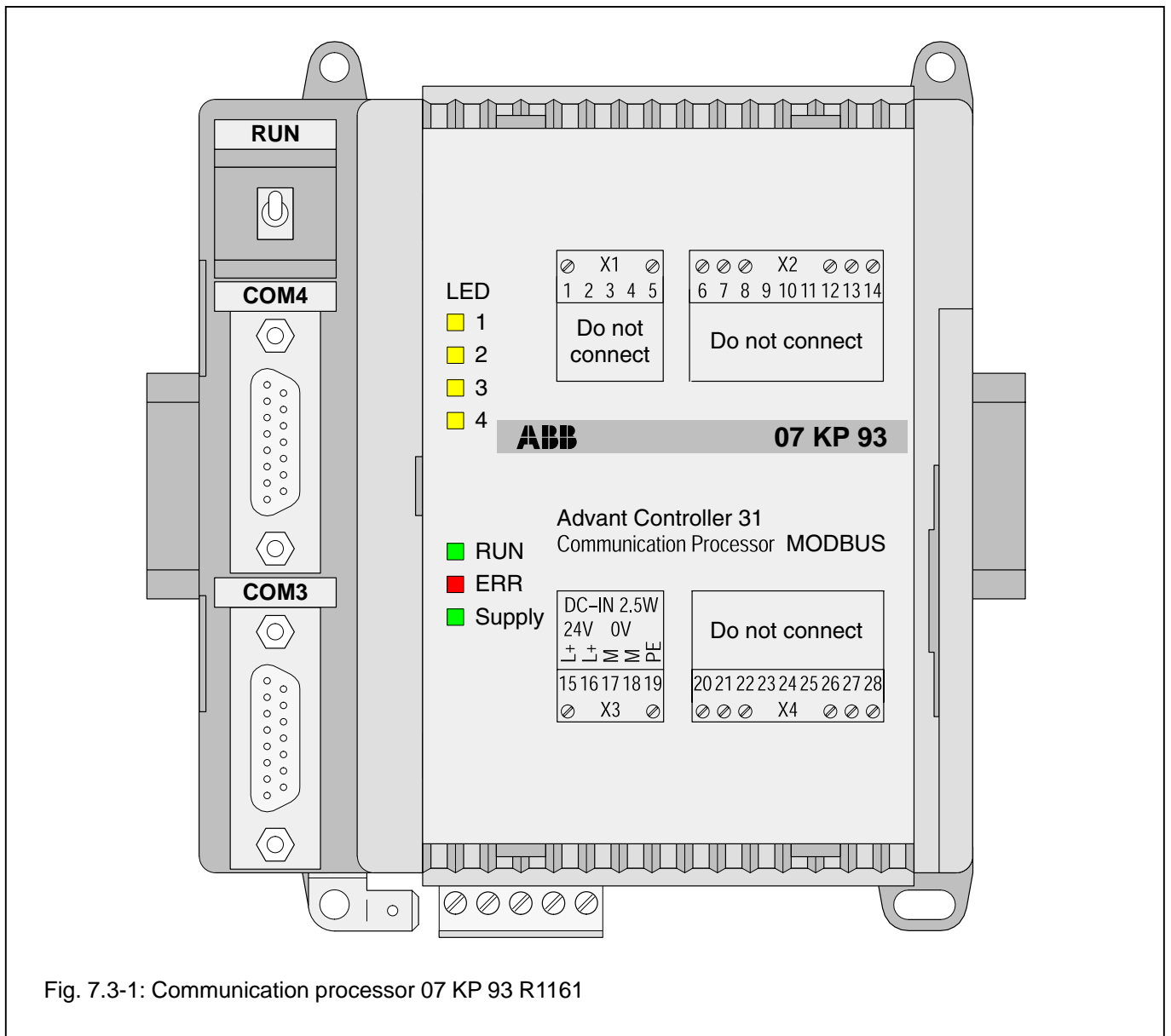

Fig. 7.3-1: Communication processor 07 KP 93 R1161

### Contents

7.3.1	Brief description.....	7.3-2
7.3.2	Structure of the front panel elements .....	7.3-3
7.3.3	Electrical connection .....	7.3-3
7.3.3.1	Application example .....	7.3-4
7.3.3.2	Connecting the supply voltage .....	7.3-5
7.3.3.3	Electrical isolation and earthing instructions .....	7.3-5
7.3.3.4	Serial interfaces.....	7.3-7
7.3.3.5	Networking interface .....	7.3-8
7.3.4	Diagnosis .....	7.3-9
7.3.5	Technical data .....	7.3-10
7.3.6	System cables .....	7.3-13
7.3.7	MODBUS RTU .....	7.3-14

### 7.3.1 Brief description

The 07 KP 93 communication processor is an interface module with 2 serial MODBUS RTU interfaces.

The communication processor allows external units to be connected to the Advant Controller 31 system using the MODBUS RTU protocol.

The most important features of the communication processor are:

- 2 serial interfaces:  
usable in accordance with EIA RS-232 or EIA RS-485 (COM3, COM4)  
  
Possible operating modes:  
COM3 COM4  
Master Slave (Master-master does not work)  
Slave Master  
Slave Slave
- Communication with AC 31 basic units is performed with function blocks / connection elements (see also programming software 907 KP 93).

#### Contact person

If you have any questions concerning the use of MODBUS, please contact our helpline:

ABB Schalt- und Steuerungstechnik GmbH  
SST/MPE  
Eppelheimer Straße 82  
D-69123 Heidelberg

Telephon: +49 6221 777-444  
Telefax: +49 6221 777-361  
EMail: [desst.helpline@de.abb.com](mailto:desst.helpline@de.abb.com)  
Internet: <http://www.abb-sst.de>

## 7.3.2 Structure of the front panel

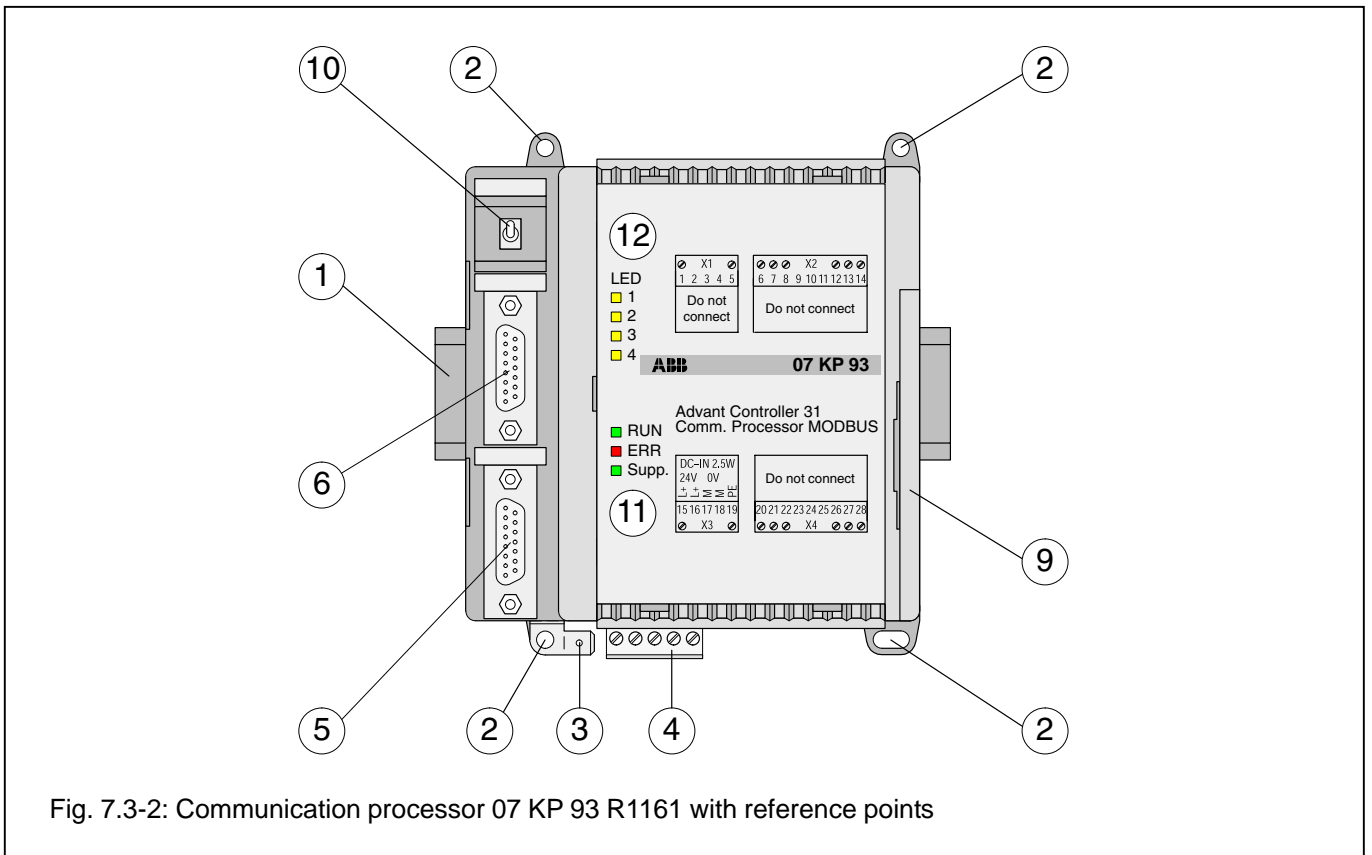

Fig. 7.3-2: Communication processor 07 KP 93 R1161 with reference points

- 1 Mounting the unit on a DIN rail**
- 2 Mounting the unit with screws**
- 3 6.3 mm Faston earthing terminal**
- 4 24 V DC supply voltage**
- 5 Serial interface COM3**
- 6 Serial interface COM4**
- 9 Networking interface for the Advant Controller 31 basic unit**
- 10 Switch not used**
- 11 LED displays for system messages**  
Refer to chapter 7.3.4 Diagnosis for further information
- 12 LED displays for system messages**  
Refer to chapter 7.3.4 Diagnosis for further information

<p><b>12</b></p> <p>gelb</p> <p>gelb</p> <p>gelb</p> <p>gelb</p>	<p><input type="checkbox"/> LED1</p> <p><input type="checkbox"/> LED2</p> <p><input type="checkbox"/> LED3</p> <p><input type="checkbox"/> LED4</p>
<p><b>11</b></p> <p>grün</p> <p>rot</p> <p>grün</p>	<p><input type="checkbox"/> RUN</p> <p><input type="checkbox"/> ERR</p> <p><input type="checkbox"/> Supply</p>

## 7.3.3 Electrical connection

### 7.3.3.1 Application example

The following illustration shows an application example with the 07 KT 97 basic unit.

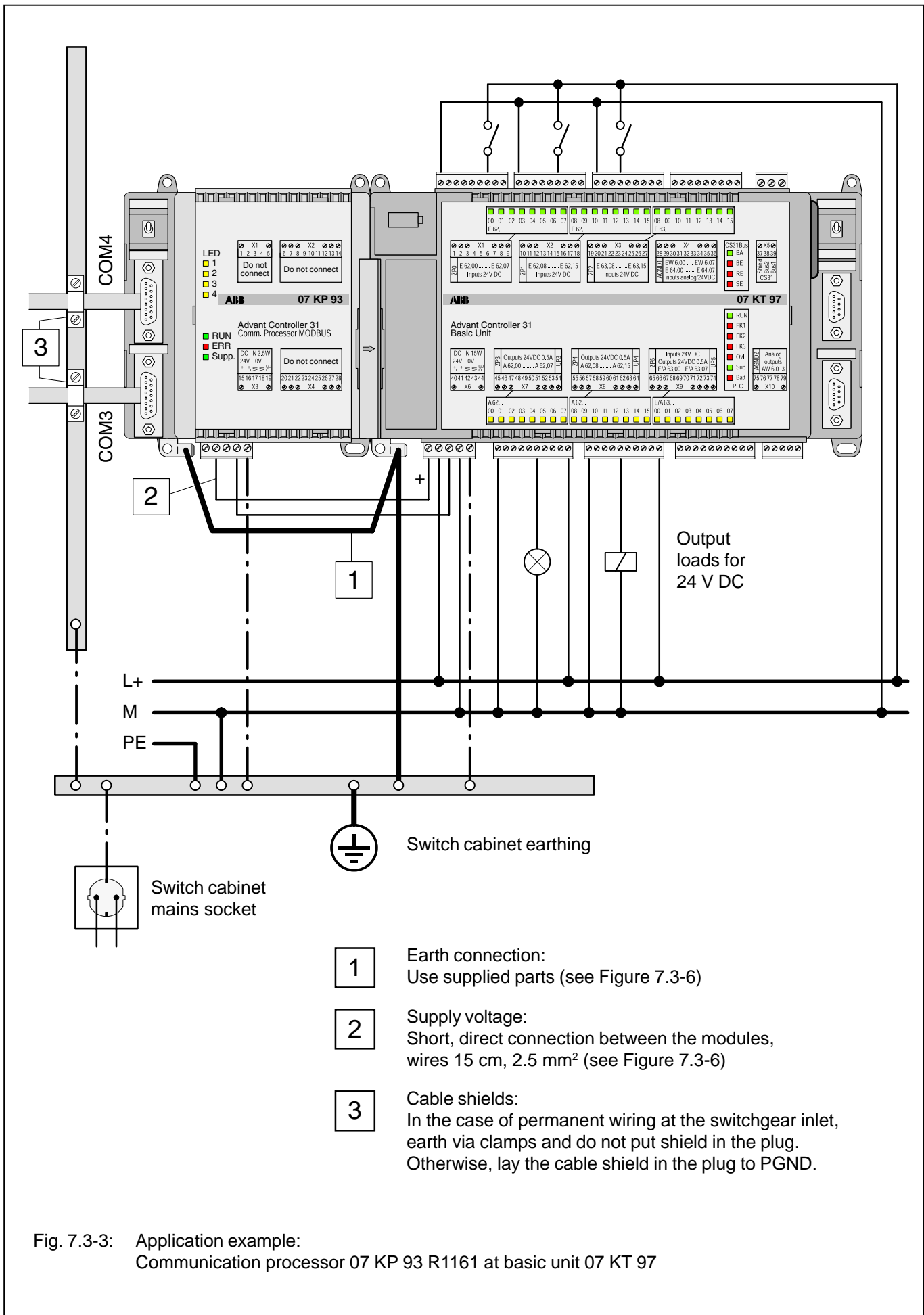

Fig. 7.3-3: Application example:  
Communication processor 07 KP 93 R1161 at basic unit 07 KT 97

### 7.3.3.2 Connecting the 24 V DC supply voltage

The supply voltage is fed in via a 5-pole detachable terminal block.

**Important:**

**Plug and unplug terminal block only with power is off!**

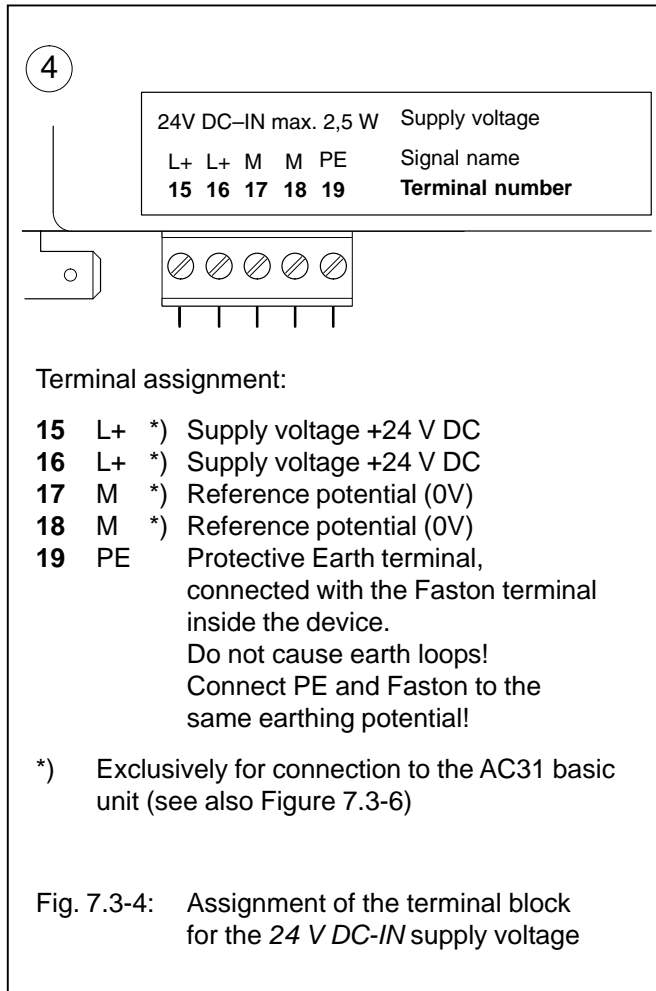

Fig. 7.3-4: Assignment of the terminal block for the 24 V DC-IN supply voltage

### 7.3.3.3 Electrical isolation and notes on earthing

The Protective Earth is connected to the 6.3 mm Faston terminal via a wire with a cross section of 6 mm<sup>2</sup> (maximum length 25 cm).

The signals of the interfaces COM3 and COM4 are electrically isolated from each other and also from the internal electronics of the unit.

The following illustration shows which parts of the unit are connected to PE/PGND.

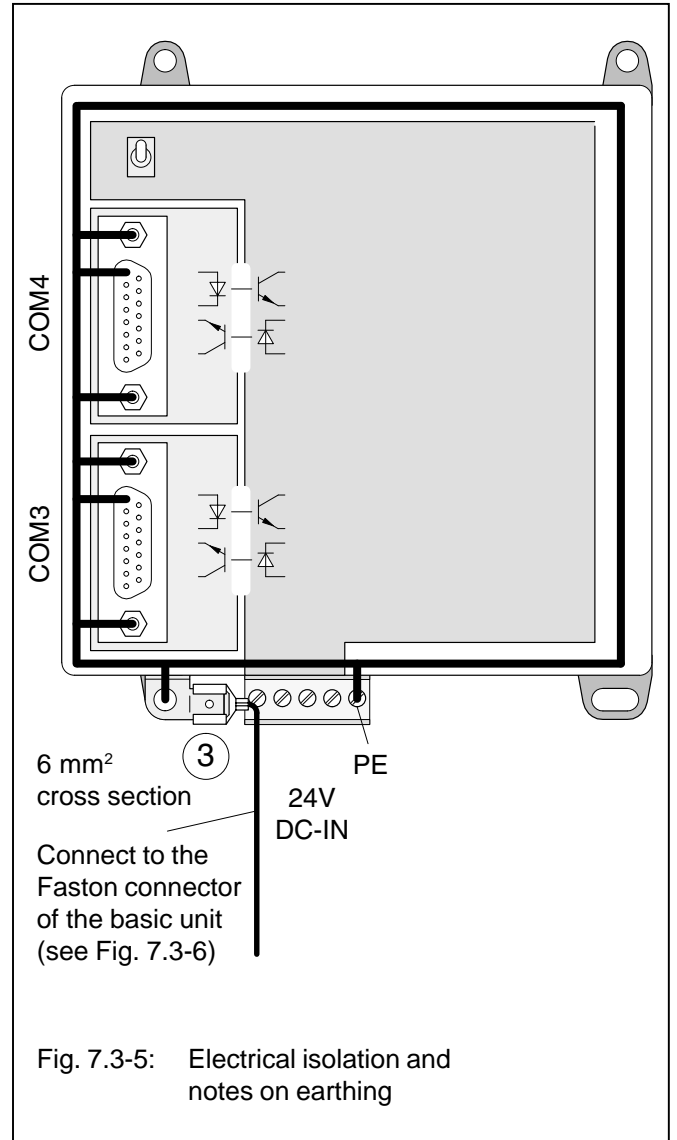

Fig. 7.3-5: Electrical isolation and notes on earthing

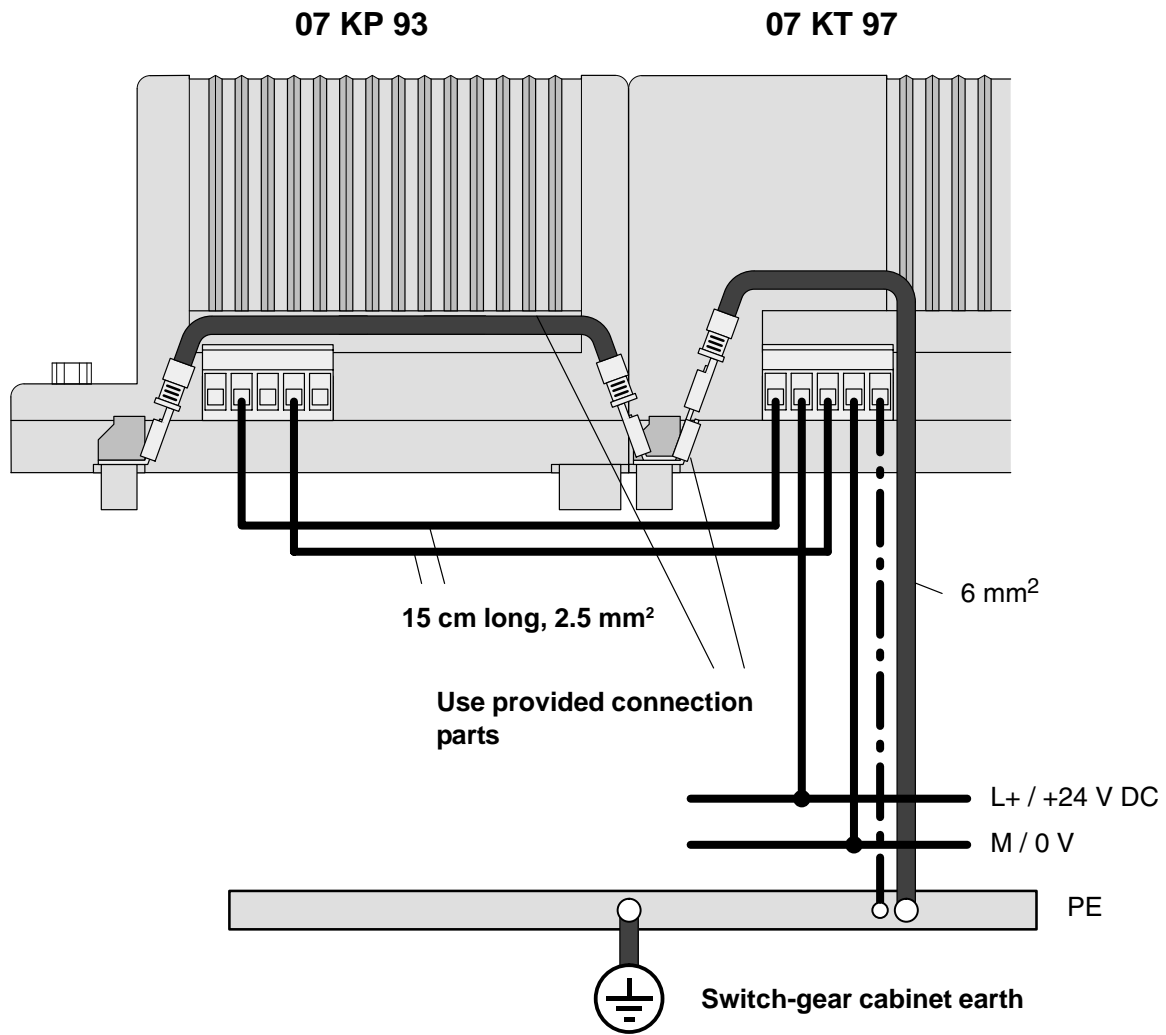

Fig. 7.3-6: Earthing connections and voltage supply for 07 KP 93 R1161



### 7.3.3.4 Serial interfaces COM3 and COM4: Pin assignment

Interface standard: EIA RS-232, EIA RS-422, EIA RS-485

5

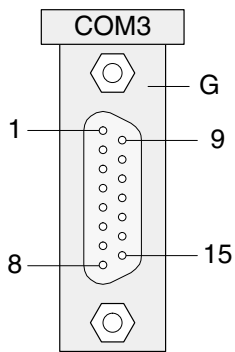

<b>G</b>	Housing	Protective Ground	(Shield)	
<b>1</b>	PGND	Protective Ground	(Shield)	
<b>2</b>	TxD	Transmit Data	(Output)	(EIA RS-232)
<b>3</b>	RxD	Receive Data	(Input)	(EIA RS-232)
<b>4</b>	RTS	Request To Send	(Output)	(EIA RS-232)
<b>5</b>	CTS	Clear To Send	(Input)	(EIA RS-232)
<b>6</b>	not used			
<b>7</b>	SGND	Signal Ground	(0V)	(EIA RS-232)
<b>8</b>	not used			
<b>9</b>	not used			
<b>10</b>	TxD-P/RxD-P	Transmit Data / Receive Data		(EIA RS-485)
<b>11</b>	TxD-N/RxD-N	<u>Transmit Data / Receive Data</u>		(EIA RS-485)
<b>12</b>	not used			
<b>13</b>	not used			
<b>14</b>	not used			
<b>15</b>	not used			

Fig. 7.3-7: Pin assignment of the serial interfaces COM3 and COM4

### 7.3.3.5 Networking interface

9

The communication processor can be connected to AC31 basic units of the 90 series which have a networking interface. The housing of the communication processor is is

connected to the housing of the AC31 basic unit by a snap-fit connection. The electrical connection is via a 40-pole ribbon cable with socket connector, soldered onto the 07 KP 93 side.

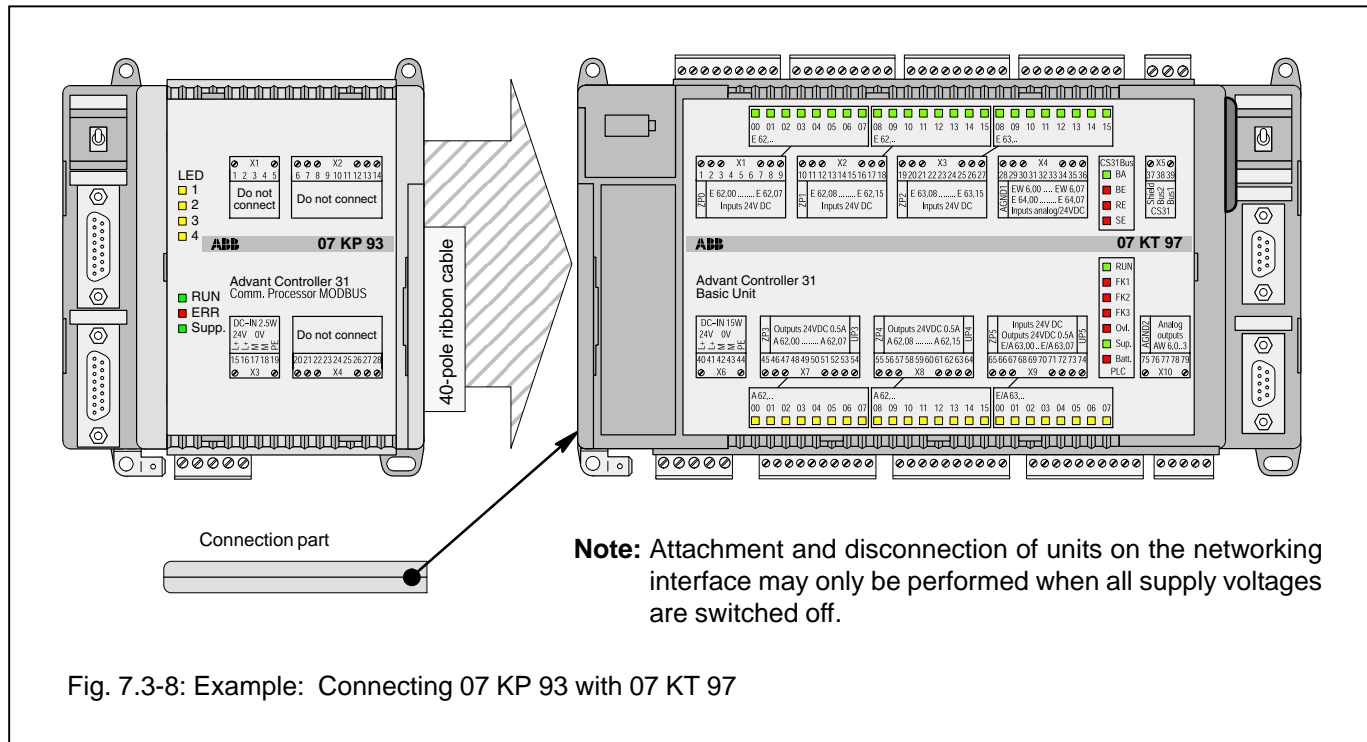

Fig. 7.3-8: Example: Connecting 07 KP 93 with 07 KT 97

### Mounting the expansion housing

1. Detach the cover on the basic unit from the networking interface.
2. Plug the socket strip of the 40-pole ribbon cable secured to the 07 KP 93 onto the networking connector of the basic unit.
3. Place both units on a level surface and slide them together so that they engage.
4. Slide in the connection part to fix the housing in position.

## 7.3.4 Diagnosis

### LED displays for system messages RUN, ERR, Supply

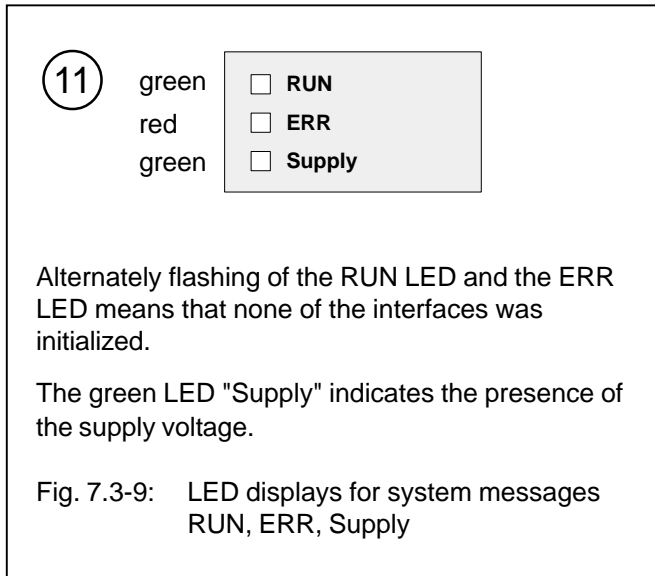

### LED displays LED1...LED4

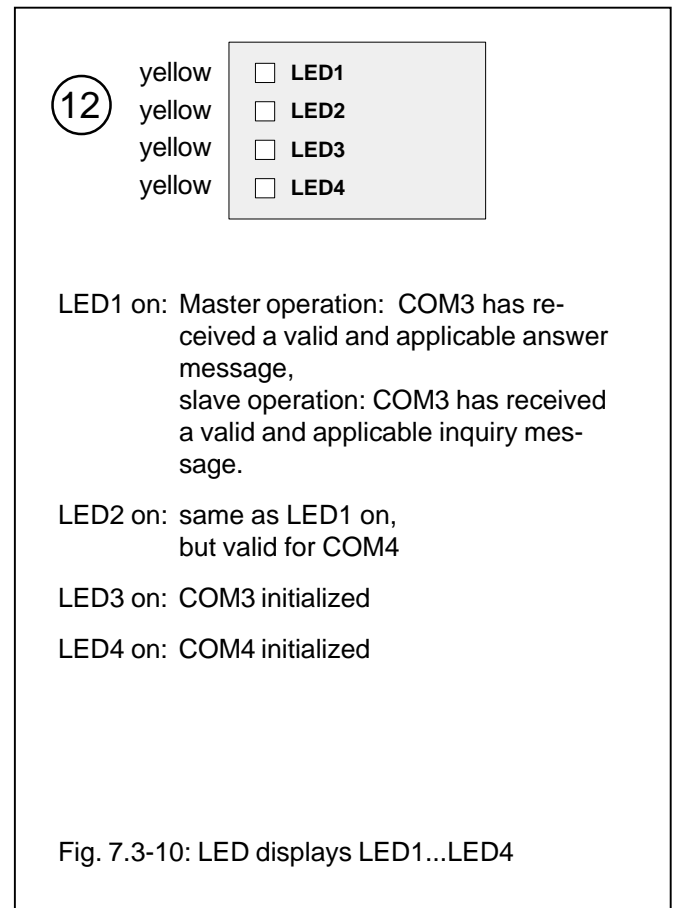

## 7.3.5 Technical data

In general, the details in section 1 "System data and system structure" of volume 2 of the system description "Advant Controller 31" apply as technical data. Supplementary and deviating data is listed below.

### 7.3.5.1 General data

Number of serial interfaces	2
Number of parallel interfaces	1 networking interface for connecting to the Advant Controller 31 basic unit
Diagnosis	4 LEDs: LED1...LED4
Operating and error displays	3 LEDs: RUN, ERR, Supply
Conductor cross section for the removable terminal blocks	max. 2.5 mm <sup>2</sup>

### 7.3.5.2 Supply voltage for 07 KP 93 R1161

Rated supply voltage	24 V DC
Power dissipation	typ. 2.5 W (max. 5W)
Max. current consumption with rated voltage	210 mA
with supply voltage 30 V	170 mA
Protection against reversed terminal connection	yes

### 7.3.5.3 Connection serial interface COM3, COM4

Interface standard	EIA RS-232 or EIA RS-485
Electrical isolation	yes, interfaces with respect to each other and with respect to the rest of the unit (also see Figure 7.3-5)
Terminal assignment and description of the interfaces COM3, COM4	see page 7.3-7

### 7.3.5.4 LED displays

- Supply	1 green LED
- ERR	1 red LED
- RUN	1 green LED
- LED1...LED4	4 yellow LEDs

description see chapter 7.3.4 Diagnosis

### 7.3.5.5 Mechanical data

Mounting on DIN rail	in accordance with DIN EN 50022–35, 15 mm deep. The DIN rail is located in the middle between the upper and the lower edges of the module.
Fastening by screws	using 4 M4 screws.
Width x height x depth	140 x 120 x 85 mm
Wiring method	by removeable terminal blocks with screw-type terminals, max. 2.5 mm <sup>2</sup>
Weight	450 g
Dimensions for mounting	see the following drawing

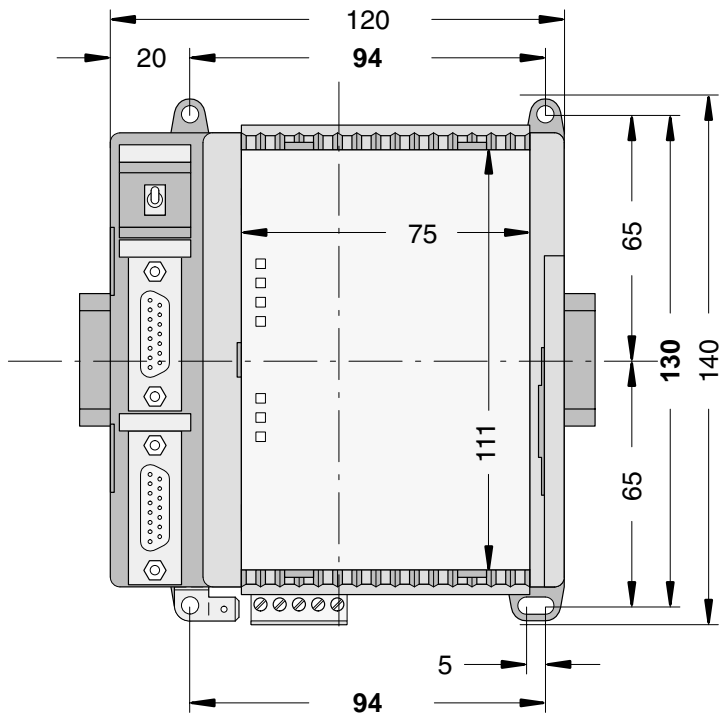

All dimensions in mm.

**The device is 85 mm deep.** The interface connectors COM3 and COM4 are set deeper so that the mounting depth required does not become any larger even with detachable interface cables. If, however, a DIN rail is used, the mounting depth is increased by the overall depth of the rail.

Fig. 7.3-11: Dimensions of the communication processor module 07 KP 93, front view, **the dimensions for assembly bore holes are printed in bold**

### 7.3.5.6 Mounting hints

Mounting position	vertical, terminals above and below
Cooling	The natural convection cooling must not hindered by cable ducts or other material mounted in the switch-gear cabinet.

### 7.3.5.7 Ordering data

Communication processor

07 KP 93 R1161 Order No. GJR5 2532 00 R1161

Scope of delivery

Communication processor 07 KP 93 R1161  
1 5-pole terminal block (5.08 mm grid),  
cable including terminals for making the  
earth connection

#### Further literature

System description Advant Controller 31, English

Order No. 1SAC 1316 99 R0201

System description ABB Procontic T200

Order No. GATS 1314 99 R2001

#### Software

Software 907 KP 93

Order No. GJP5 2072 00 R0102

## 7.3.6 System cables

### 7.3.6.1 COM3, COM4 as EIA RS-232 interfaces

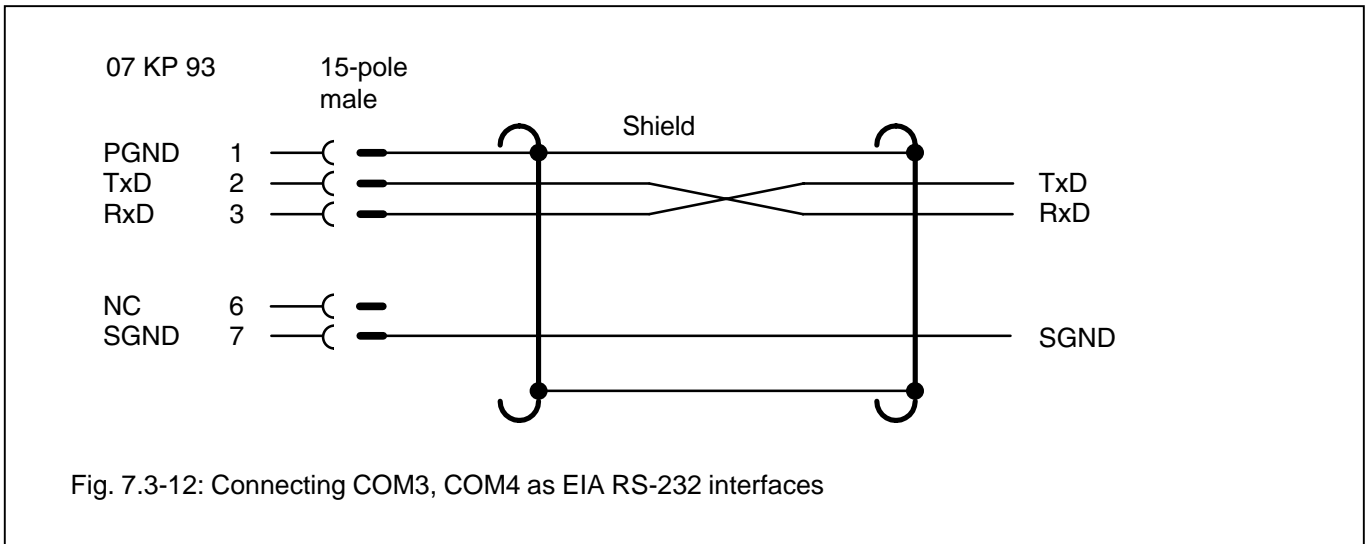

### 7.3.6.2 COM3, COM4 as EIA RS-485 interfaces

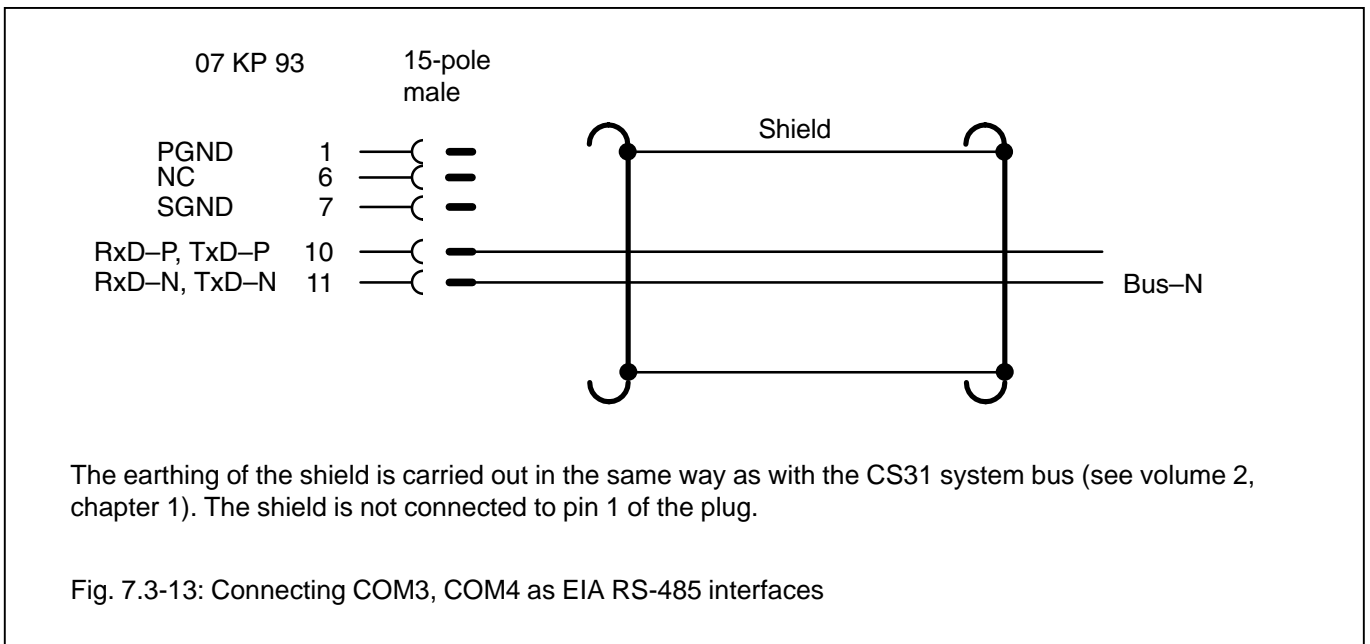

## 7.3.7 MODBUS-RTU

### Overview

#### Brief description, field of application

MODBUS-RTU is an international widely known standard. The main application is the coupling in the local area for:

- Automation systems and PLCs,

- Operating terminals

- PC operating stations / master terminals

#### Short data

- Number of user stations with EIA RS-485: 32
- Distance with EIA RS-485: max. 1.2 km
- Connection of dedicated-line modems is possible

### Networking alternatives

#### Multi-point line up to 1.2 km

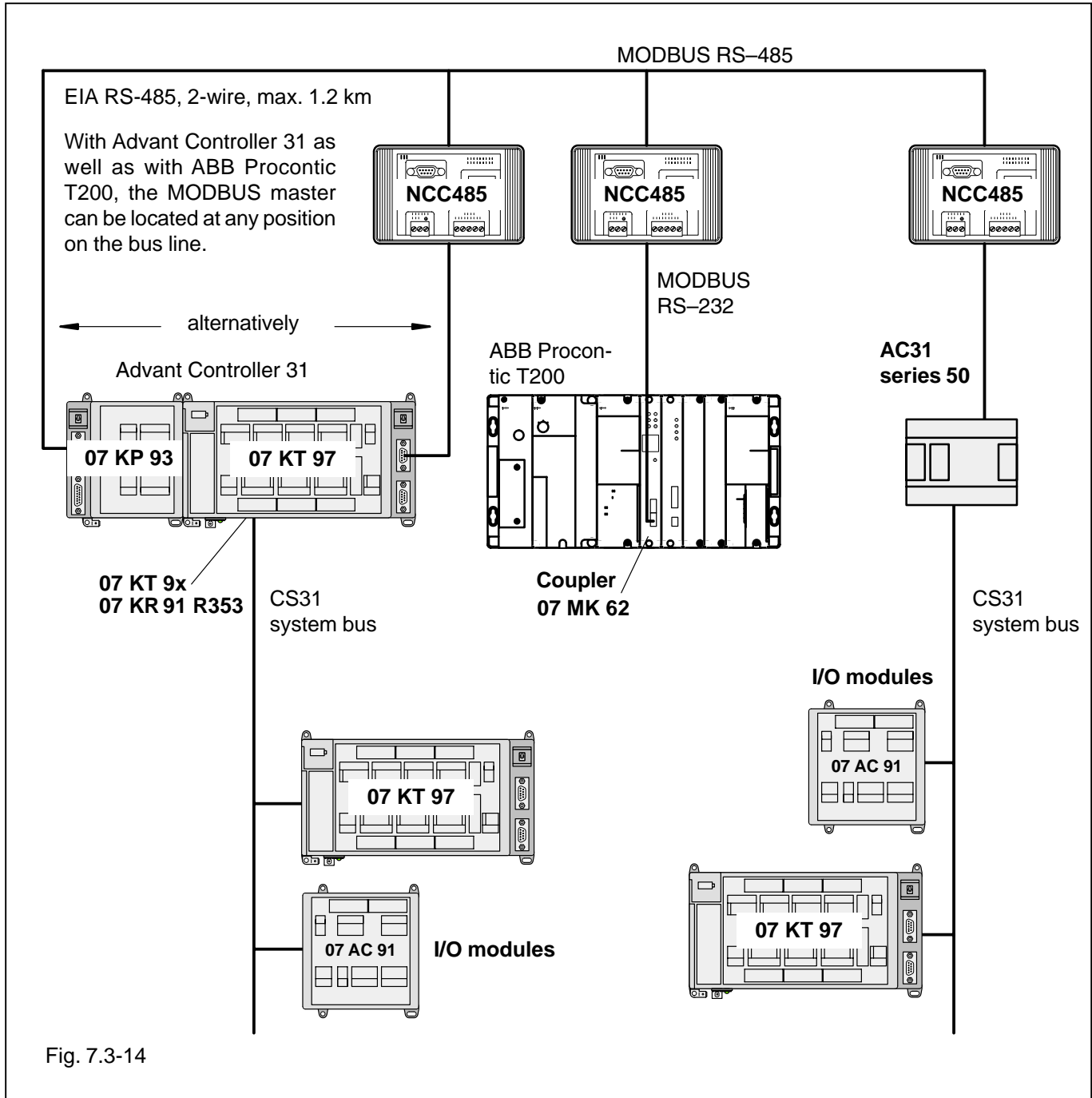
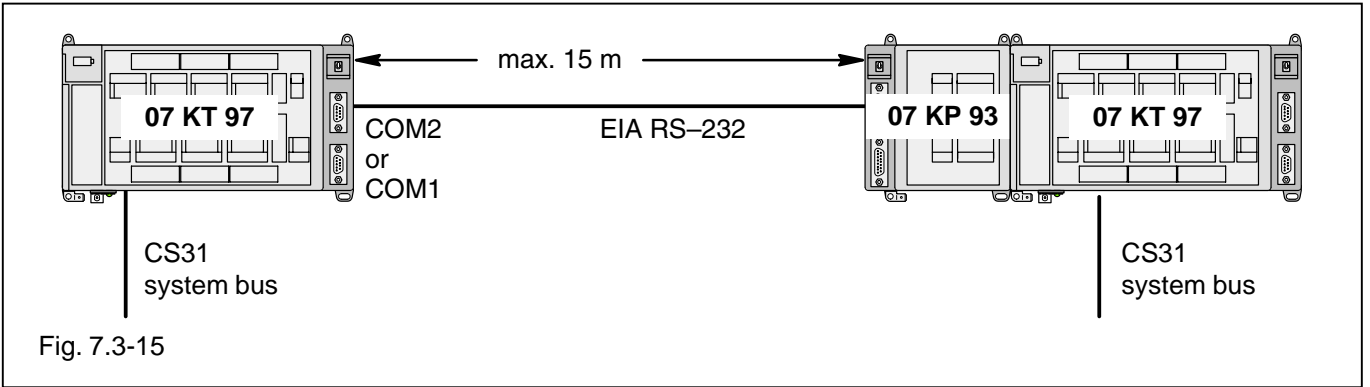

Fig. 7.3-14



**Installation example**

**Point-to-point without converter**



**Multi-point line**

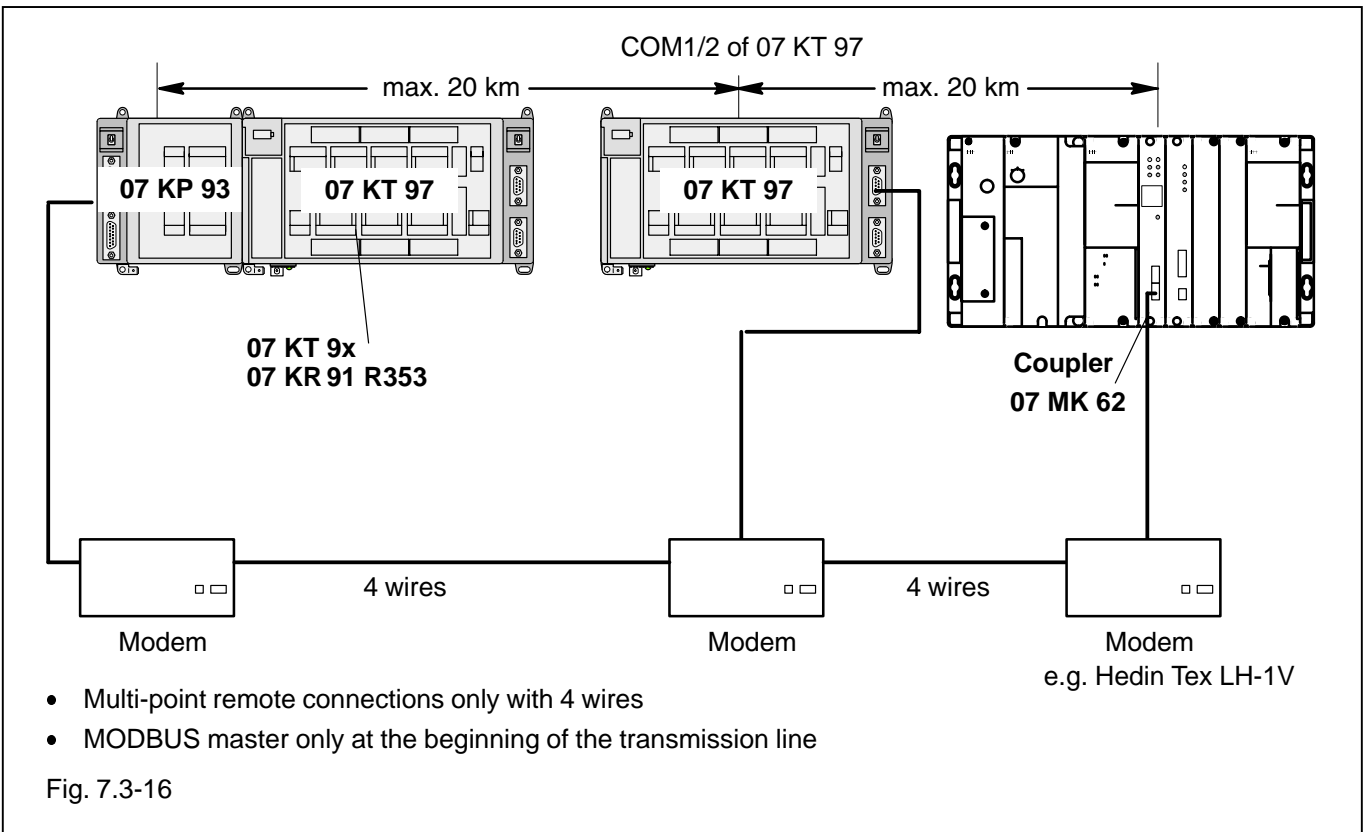

**Point-to-point, max. 1200 bits/s, 4 wires**

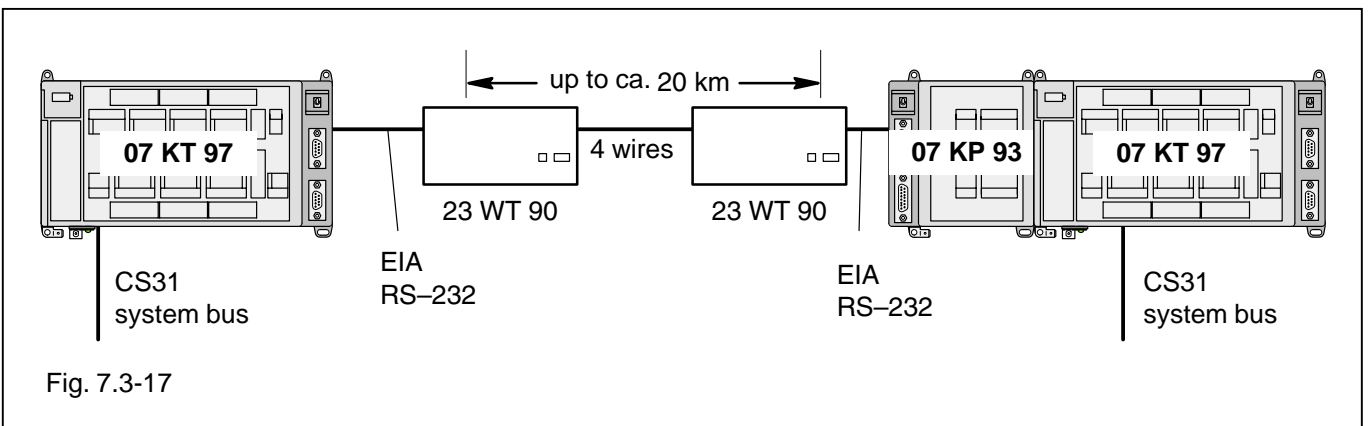

## Separate connection of an operating terminal and an operating station via MODBUS

Use is made of the fact that the coupler 07 KP 93 R1161 has 2 MODBUS interfaces when used as slave (only as slave)

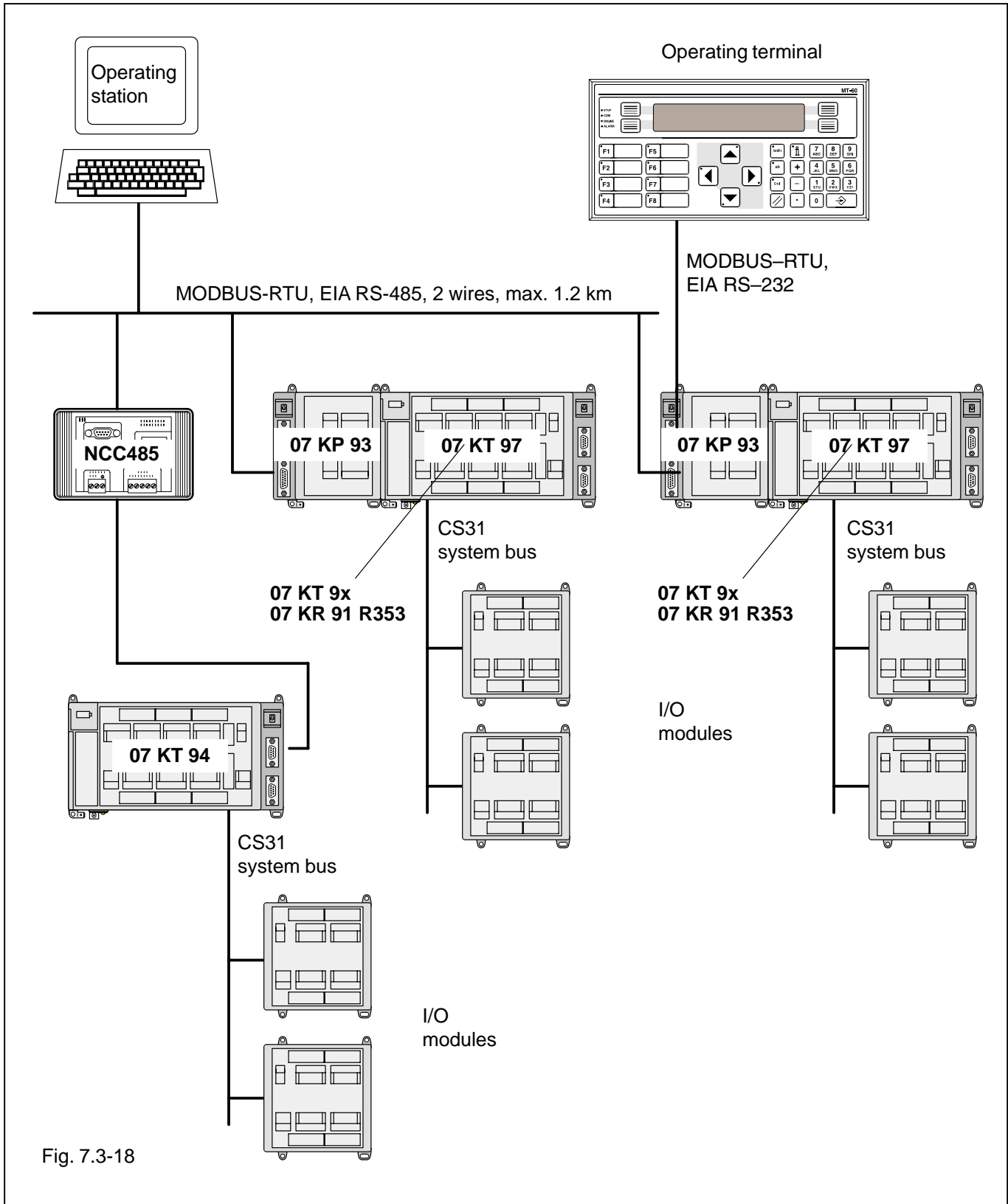

# 10 Interface Cables

---

**Interface cables** for connection between peripheral units and the 9-pole serial interfaces of the basic units 07 KR 91, 07 KT 92, 07 KT 93 and 07 KT 94 to 07 KT 97 (AC31) and the communication processors 07 KT 62 and 07 KP 64 (ABB Procontic T200):

<b>Type</b>	<b>Order number</b>
07 SK 90 R1	GJR5 2502 00 R0001
07 SK 91 R1	GJR5 2503 00 R0001
07 SK 92 R1	GJR5 2504 00 R0001



## 10.1 Interface Cables 07 SK 90 R1, 07 SK 91 R1 and 07 SK 92 R1

for connection of peripheral units to the 9-pole serial interfaces of the basic units 07 KR 91 and 07 KT 9x (Advant Controller 31) and the communication processors 07 KP 62 and 07 KP 64 (ABB Procontic T200) and 07 KP 90 (Advant Controller 31)

### 10.1.1 Survey table

The following table shows, which interface cables can be used for connections between peripheral units and the 9-pole interfaces of the AC31 basic units and the T200 communication processors.

Connection from the processor unit interface	via the system cable (interface cable)	to the peripheral unit
07 KR 91 COM1 07 KT 9x COM1 07 KP 62 COM1	07 SK 90	PC programming unit
07 KR 91 COM1 07 KT 92 COM1 07 KT 93 COM1 07 KT 94 COM1 07 KP 62 COM1	07 SK 90	Operating station in active mode
07 KR 91 COM1 07 KT 92 COM1 07 KT 93 COM1 07 KT 94 COM1 07 KP 62 COM1 07 KP 64 CONSOLE 07 KP 90 CONSOLE	07 SK 90	Terminal
07 KR 91 COM1 07 KT 9x COM1 07 KT 9x COM2 07 KP 62 COM1 07 KP 62 COM2	07 SK 91	Operating station in passive mode
07 KR 91 COM1 07 KT 9x COM1 07 KT 9x COM2 07 KP 62 COM1 07 KP 62 COM2 07 KP 64 RCOM 07 KP 90 RCOM	07 SK 92	Modem with a standard interface, for signal names and pin assignment see chapter 10.4

## 10.2 Interface Cable 07 SK 90 R1 with adaptor

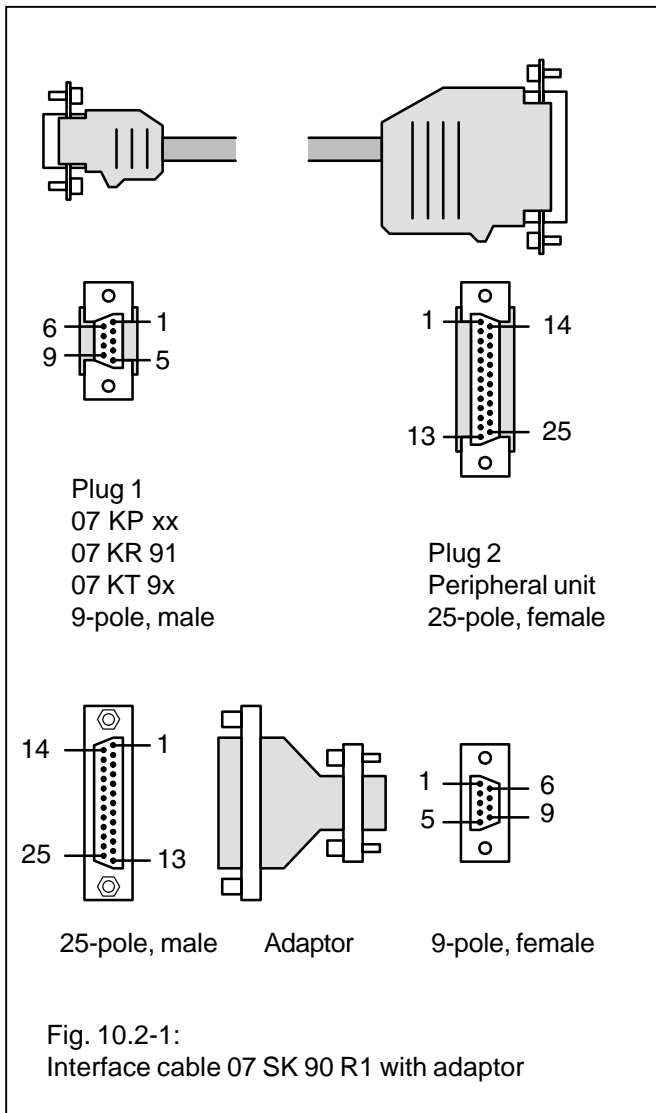

### Intended purpose

The cable 07 SK 90 is used to connect a 9-pole interface connector of AC31 basic units or T200 communication processors with a peripheral unit in order to operate in programming or active mode (see 10.1.1 Survey table). If the peripheral has a 9-pole interface, the adaptor provided with (25-pole to 9-pole) can be employed for adaption.

### Mechanical design

#### Plug 1

SUB-D plug, 9-pole male on the side of 07 KP 6x, 07 KR 91, 07 KT 9x. The housing is metal-plated, the shield is connected to the metal plate.

#### Plug 2

SUB-D plug, 25-pole female, on the side of the peripheral unit. The plugs are mounted to both interfaces by means of screws.

#### Cable type

LICYCY 5 x 0.14/15

#### Adaptor provided

25-pole male/9-pole female for connection of peripheral units with 9-pole interfaces (male).

### Technical data

Length	5 m
Weight	220 g
Order number	GJR5 2502 00 R1

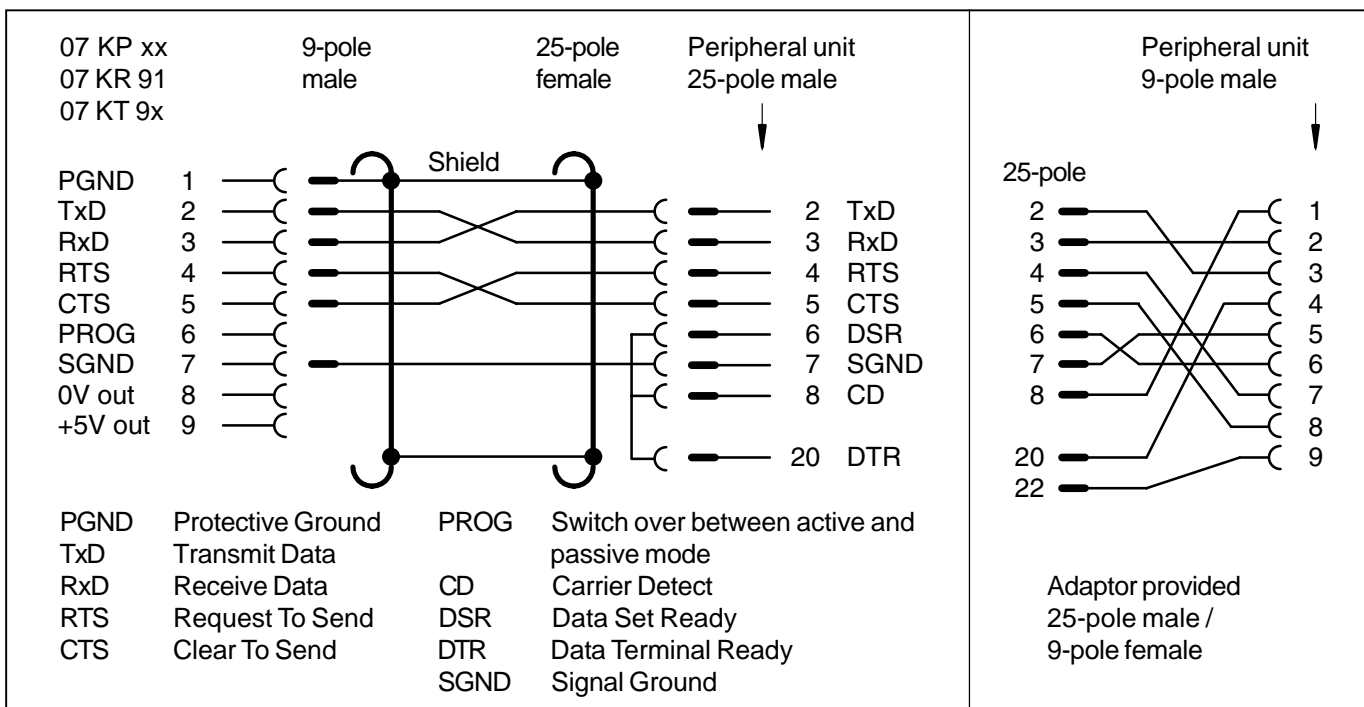
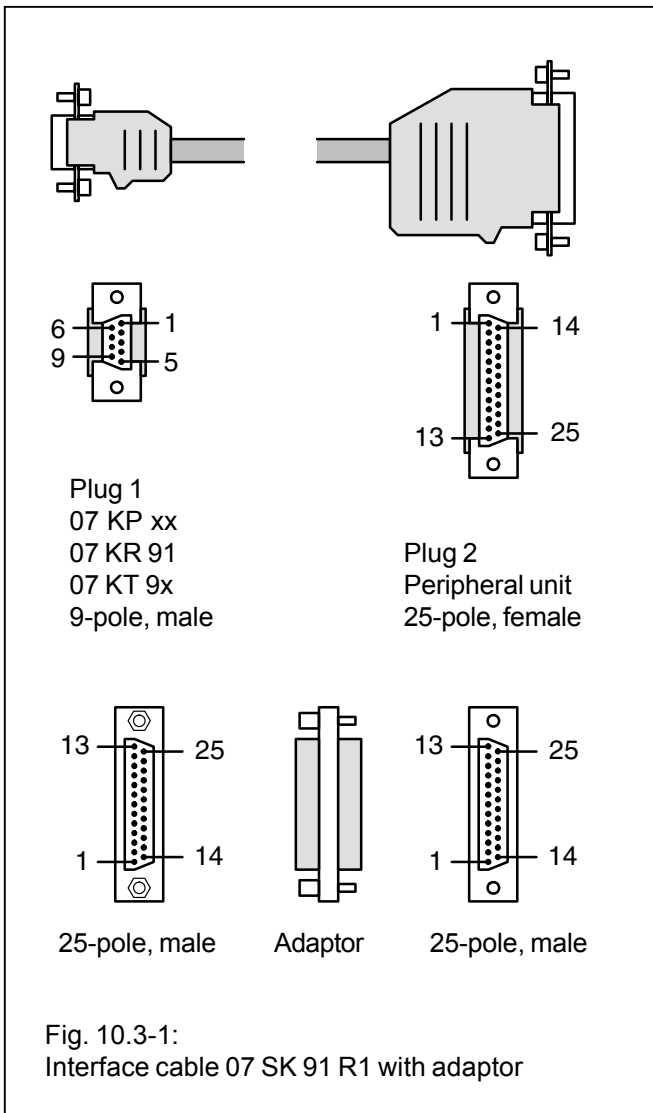

Fig. 10.2-2: Terminal assignment of the 07 SK 90 interface cable and the adaptor provided with

### 10.3 Interface cable 07 SK 91 R1 with adaptor



#### Intended Purpose

The cable 07 SK 91 is used to connect a 9-pole interface connector of AC31 basic units or T200 communication processors with a peripheral unit in order to operate in MMC mode or passive mode (see 10.1.1 Survey table). If the peripheral unit has a 9-pole connector, a commercially available adaptor (25-pole to 9-pole) has to be employed for adaption.

#### Mechanical design

##### Plug 1

SUB-D plug, 9-pole male on the side of 07 KP 6x, 07 KR 91, 07 KT 9x. The housing is metal-plated, the shield is connected to the metal plate.

##### Plug 2

SUB-D plug, 25-pole female on the side of the peripheral unit. The plugs are mounted to both interfaces by means of screws.

##### Cable type

LICYCY 5 x 0.14/15

##### Adaptor provided

25-pole male/25-pole male for connection of peripheral units with 25-pole interfaces (female).

#### Technical data

Length	5 m
Weight	220 g
Order number	GJR5 2503 00 R1

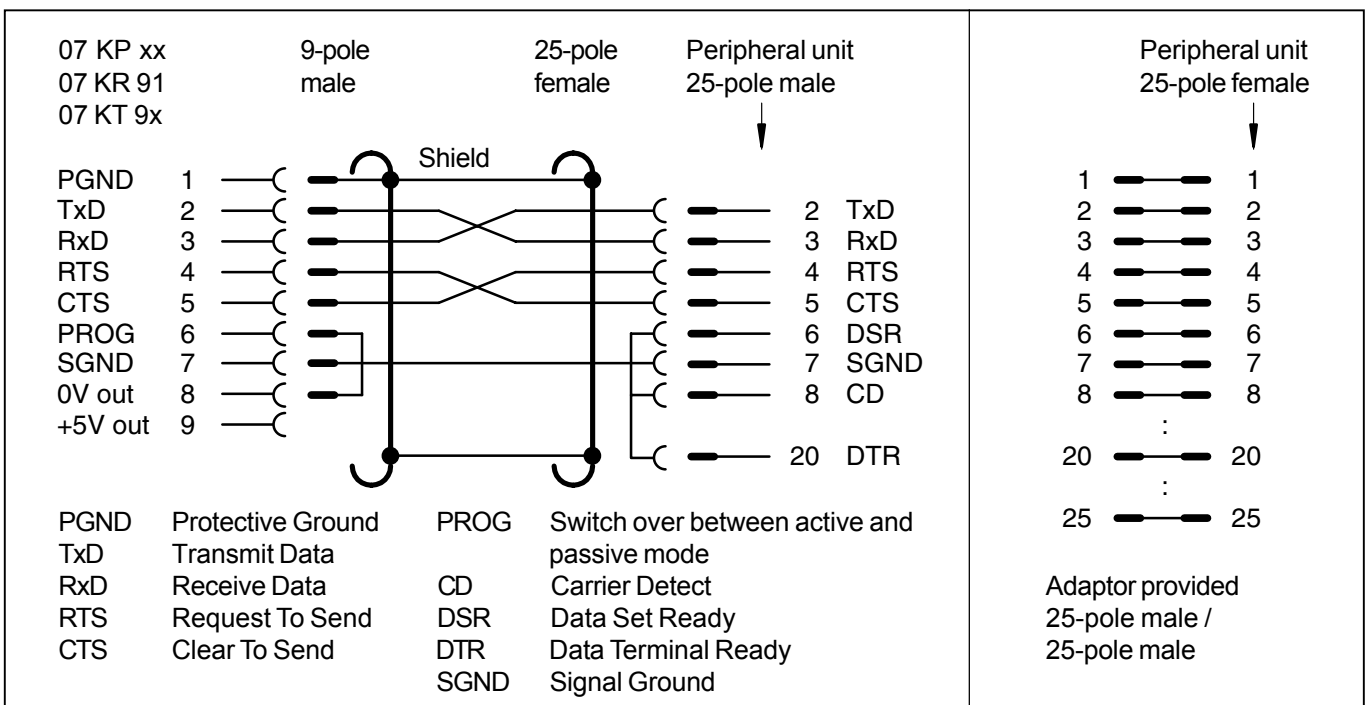
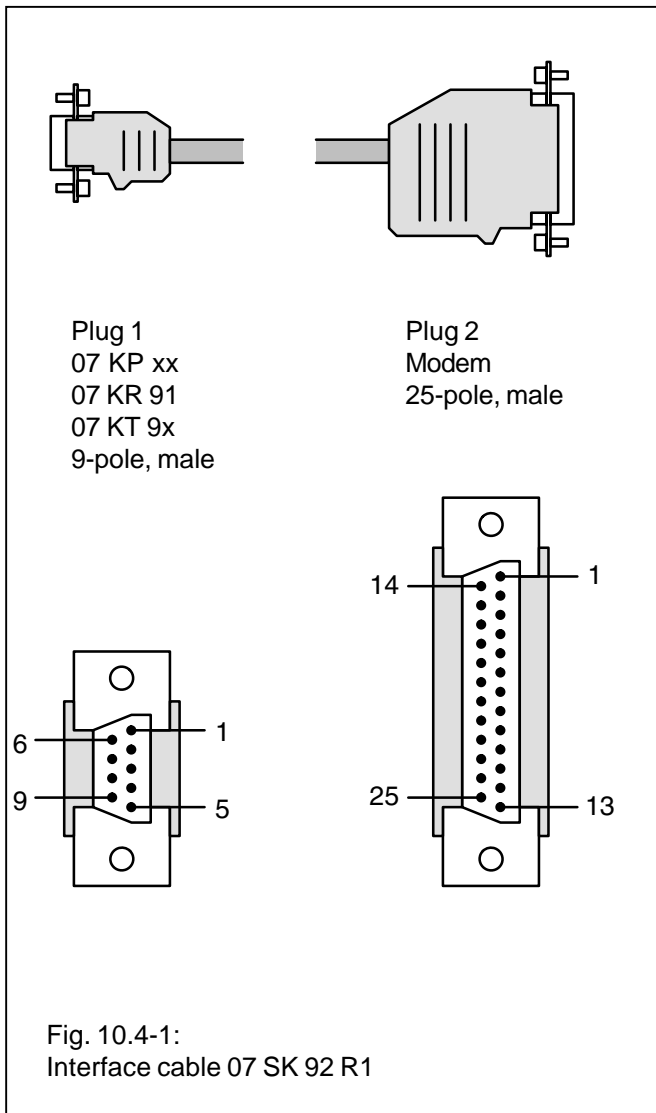

Fig. 10.2-3: Terminal assignment of the 07 SK 91 interface cable and the adaptor provided with

## 10.4 Interface cable 07 SK 92 R1



### Intended purpose

The cable 07 SK 92 is used to connect a 9-pole interface connector of AC31 basic units or T200 communication processors to a modem with a standard interface (see 10.1.1 Survey table). If another modem has to be connected, the cable has to be modified possibly.

### Mechanical design

#### Plug 1

SUB-D plug, 9-pole male on the side of 07 KP 6x, 07 KR 91, 07 KT 9x. The housing is metal-plated, the shield is connected to the metal plate.

#### Plug 2

SUB-D plug, 25-pole male on the side of the modem. The plugs are mounted to both interfaces by means of screws.

#### Cable type

LICYCY 5 x 0.14/15

#### Technical data

Length	5 m
Weight	220 g
Order number	GJR5 2504 00 R1

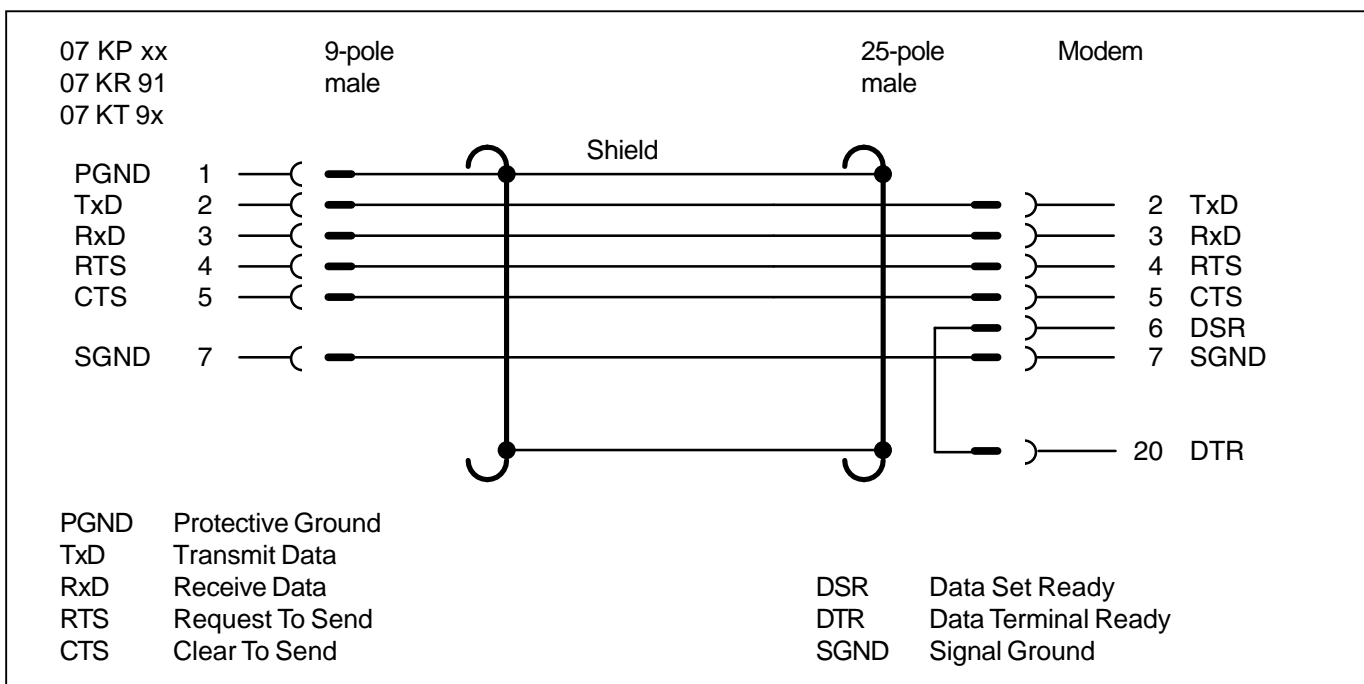

Fig. 10.2-4: Terminal assignment 07 SK 92



# 11 Accessories

---

Type	Order number
<b>Power Supply Unit 07 NG 32, 24 V DC, 2,5 A</b>	<b>GJV3 0756 01 R1</b>
<b>Power Supply Unit 07 NG 34, 24 V DC, 5 A</b>	<b>GJV3 0756 02 R1</b>
<b>Power Supply Unit 07 NG 35, 24 V DC, 10 A</b>	<b>GJV3 0756 03 R1</b>
<b>Power Supply Unit 07 NG 36, 24 V DC, 20 A</b>	<b>GJV3 0756 04 R1</b>
<b>Lithium Battery Module 07 LE 90 R1</b> for use in processor units	<b>GJR5 2507 00 R1</b>
<b>SmartMedia Card 07 MC 90 R1</b>	<b>GJR5 2526 00 R0101</b>



## 11.1 Power Supply Unit 07 NG 32 R1

primary voltage: 115/230 V AC, secondary voltage: 24 V DC, 2.5 A

The 07 NG 32 R1 power supply unit generates a 24 V DC voltage from a single-phase mains voltage of 115 V AC or 230 V AC. For applications in electronic control systems, the output voltage is smoothed by electrolytic capacitors. The power supply unit has a load capability of 2.5 A. A green LED indicates that the output voltage is present.

The primary and the secondary voltage are protected by built-in miniature fuses (5 x 20 mm). The electrical connections are made via screw-type terminals (see Fig. 11.1-1, Top view with circuit diagram imprint and terminal assignment). Cable grips fasten the cables. There is an

electrical isolation between the primary and the secondary voltage according to VDE 0551 (safety electrical isolation).

The power supply unit has a mounting base which allows the user to snap the unit onto a DIN rail (EN 50022). If this mounting base is removed, the unit can be fastened by 4 screws M4 (see Fig. 11.1-2, drilling pattern).

The power supply unit must be mounted so that the convection air current is not disturbed.

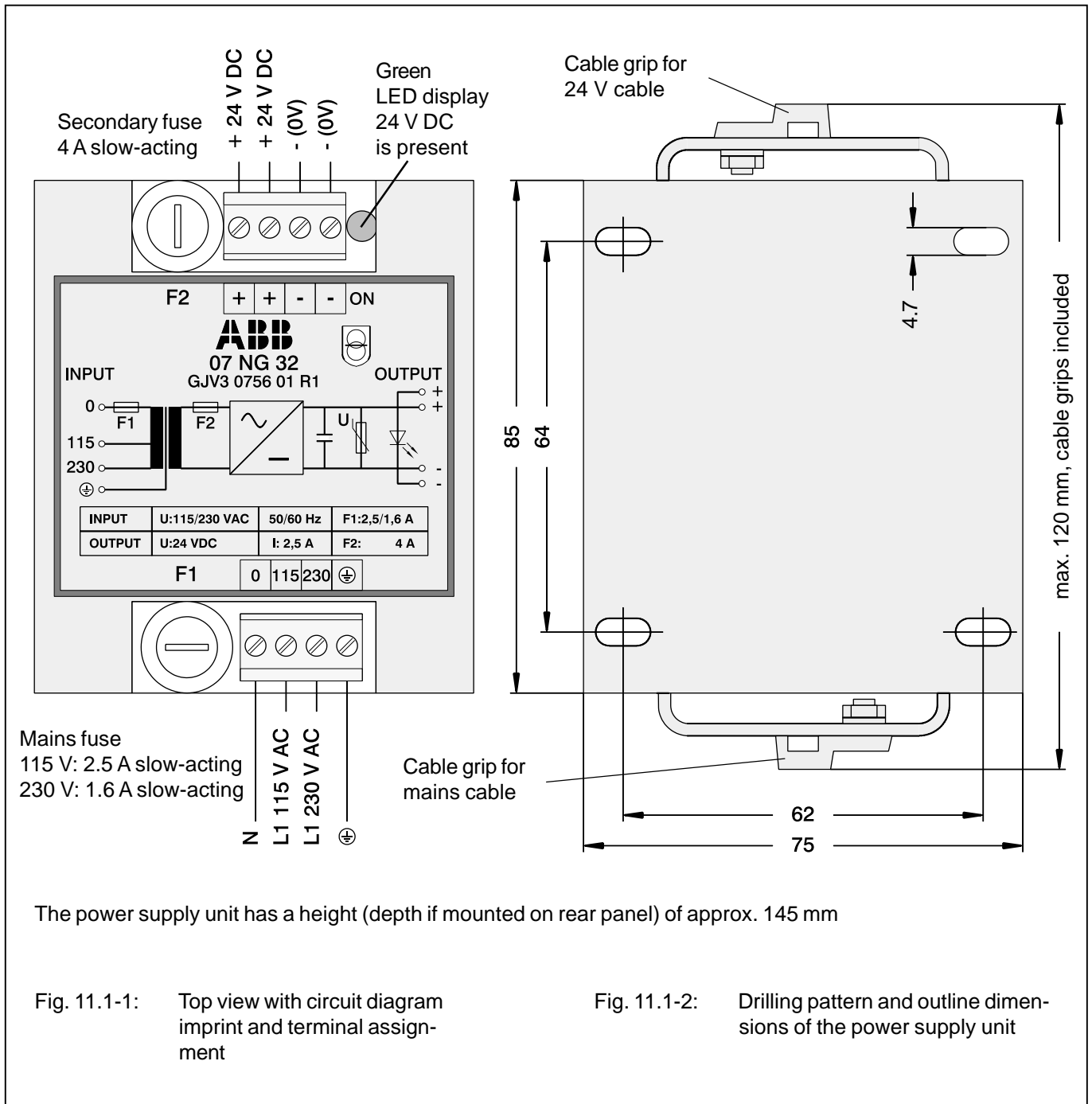

The power supply unit has a height (depth if mounted on rear panel) of approx. 145 mm

Fig. 11.1-1: Top view with circuit diagram imprint and terminal assignment

Fig. 11.1-2: Drilling pattern and outline dimensions of the power supply unit

## Technical data

### Electrical data, input specifications

#### Primary voltage **115 V AC**

Rated voltage		115 V AC
Limiting values		103.5...126.5 V AC
Mains frequency		50 or 60 Hz
Current consumption	with no load	approx. 180 mA
	with rated load	approx. 900 mA
Miniature fuse primary		2.5 A slow-acting, sand-filled

#### Primary voltage **230 V AC**

Rated voltage		230 V AC
Limiting values		207...253 V AC
Mains frequency		50 or 60 Hz
Current consumption	Leerlauf	approx. 90 mA
	Nennlast	approx. 450 mA
Miniature fuse primry		1.6 A slow-acting, sand- filled (inserted by factory)

Max. conductor cross section of the terminals 2.5 mm<sup>2</sup>

### Electrical data, output specifications

#### Secondary voltage (output voltage)

Rated voltage	24 V DC
Limiting values	19.2...30 V DC
Max. ripple content	≤ 5 %
Indication "voltage present"	by green LED

#### Output load capability

Rated current (permitted continuous load) 2.5 A

Miniature fuse, secondary 4.0 A medium time-lag, sand-filled

Max. conductor cross section of the terminals 2.5 mm<sup>2</sup>, plus and minus poles are assigned to two terminals each (in parallel)

### Mechanical data

Mounting onto a DIN rail or with 4 screws M4

#### Mechanical dimensions

Mounting base 85 x 75 mm (120 mm), see Fig. 11.1-2, Drilling pattern  
Height (depth if mounted on rear panel) 145 mm

Weight 2.2 kg

Cooling The power supply unit must be mounted so that the convection air current is not disturbed.

Ambient temperature max. 55 °C (at 100 % load)

Standards, regulations VDE 0160, transformer according to VDE 0551

### Ordering data

Order number 07 NG 32 R1 GJV3 0756 01 R1

## 11.2 Power Supply Unit 07 NG 34 R1

primary voltage: 115/230 V AC, secondary voltage: 24 V DC, 5 A

The 07 NG 34 R1 power supply unit generates a 24 V DC voltage from a single-phase mains voltage of 115 V AC or 230 V AC. For applications in electronic control systems, the output voltage is smoothed by electrolytic capacitors. The power supply unit has a load capability of 5 A. A green LED indicates that the output voltage is present.

The primary and the secondary voltage are protected by built-in miniature fuses (5 x 20 mm). The electrical connections are made via screw-type terminals (see

Fig. 11.2-1, Top view with circuit diagram imprint and terminal assignment). Cable grips fasten the cables. There is an electrical isolation between the primary and the secondary voltage according to VDE 0551 (safety electrical isolation). The power supply is fastened by 4 screws M5 (see Fig. 11.2-2, drilling pattern).

The power supply unit must be mounted so that the convection air current is not disturbed.

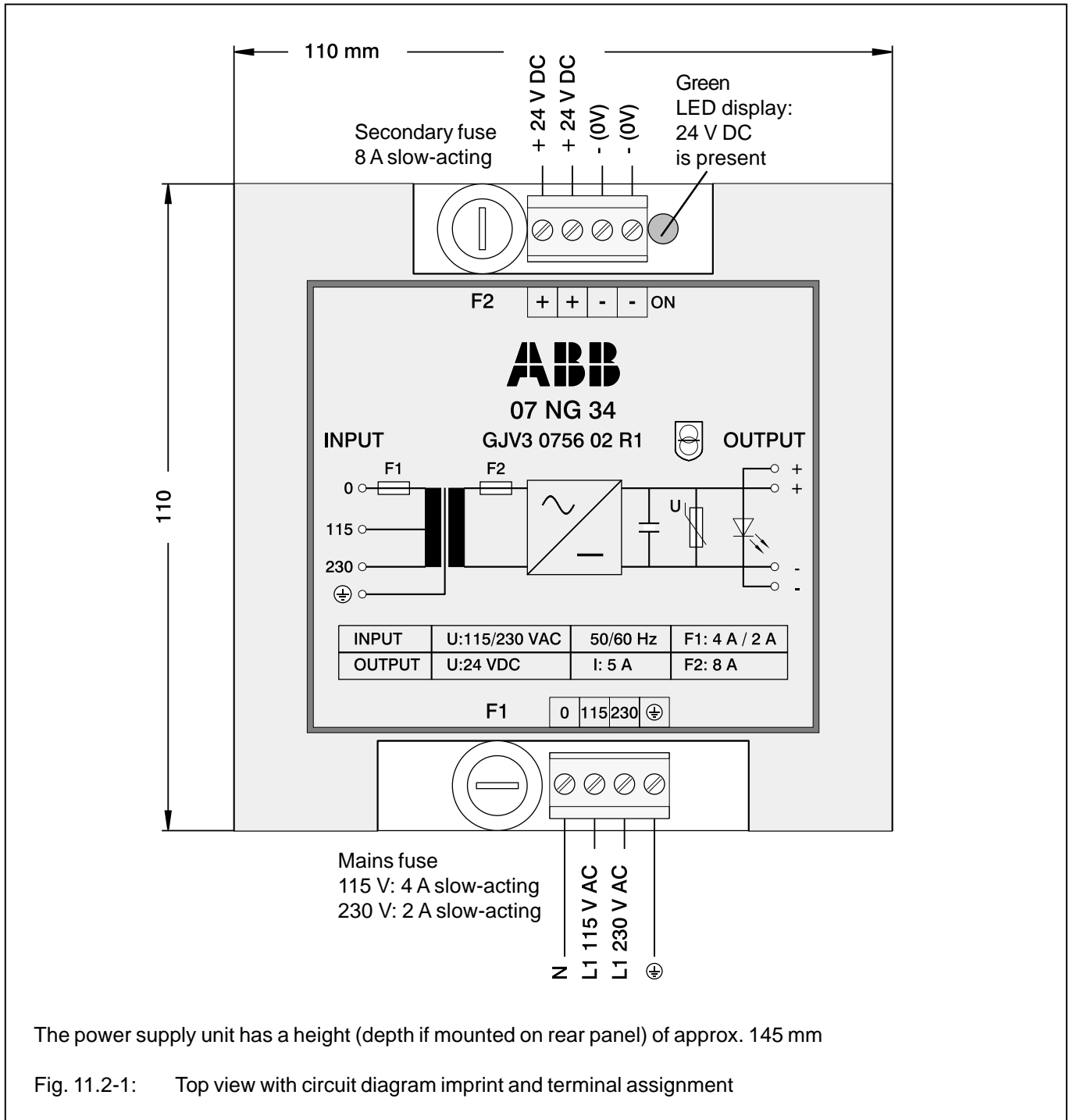

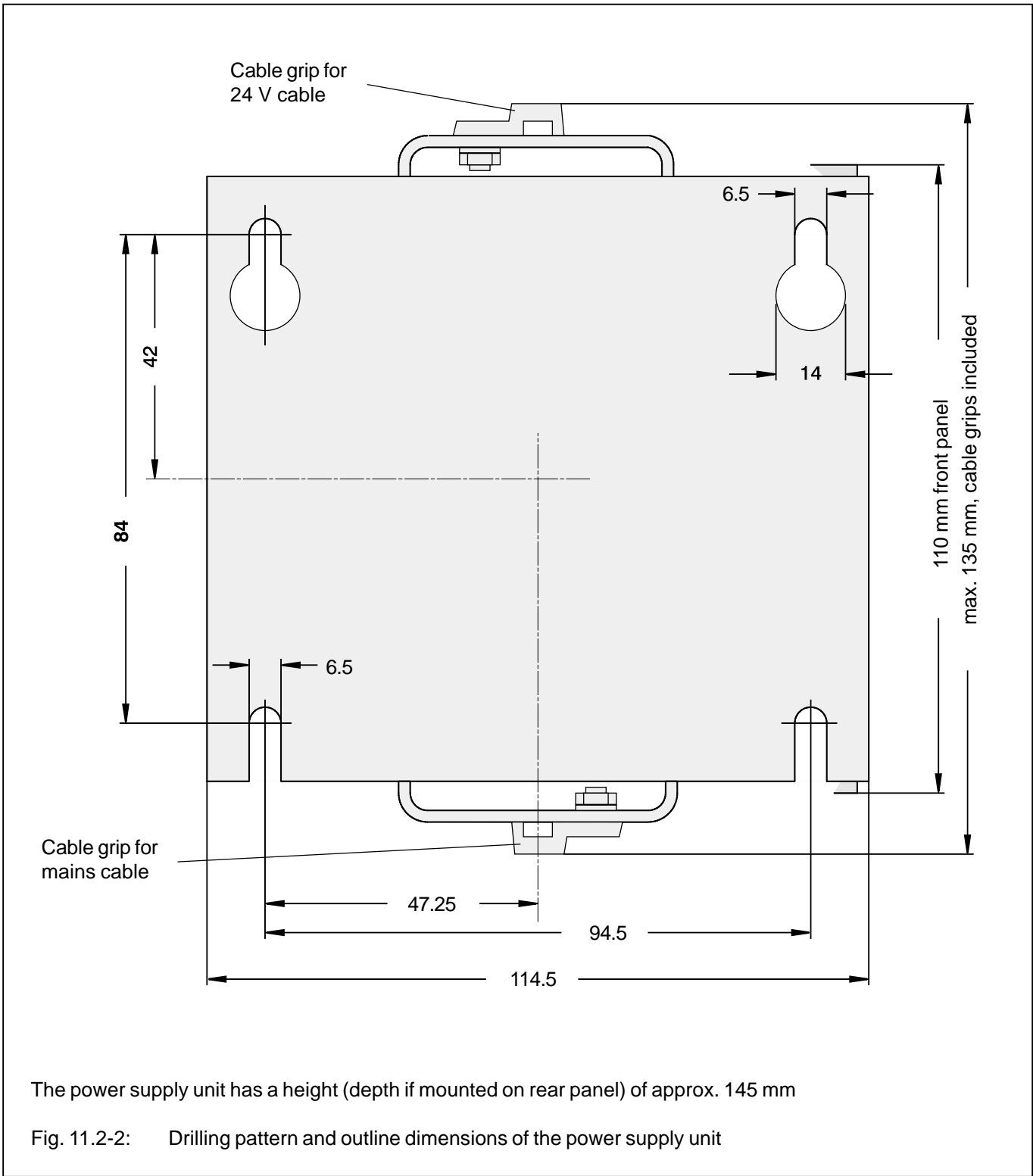

## Technical data

### Electrical data, input specifications

#### Primary voltage **115 V AC**

Rated voltage		115 V AC
Limiting values		103.5...126.5 V AC
Mains frequency		50 or 60 Hz
Current consumption	with no load	approx. 0.35 A
	with rated load	approx. 1.60 A
Miniature fuse primary		4 A slow-acting, sand-filled

#### Primary voltage **230 V AC**

Rated voltage		230 V AC
Limiting values		207...253 V AC
Mains frequency		50 or 60 Hz
Current consumption	with no load	approx. 0.17 A
	with rated load	approx. 0.85 A
Miniature fuse, primary		2 A slow-acting, sand-filled (inserted by factory)
Max. conductor cross section of the terminals		2.5 mm <sup>2</sup>

### Electrical data, output specifications

#### Secondary voltage (output voltage)

Rated voltage	24 V DC
Limiting values	19.2...30 V DC
Max. ripple content	≤ 5 %
Indication "voltage present"	by green LED

#### Output load capability

Rated current (permitted continuous load)	5 A
---	-----

#### Miniature fuse, secondary

8 A medium time-lag, sand-filled

#### Max. conductor cross section of the terminals

2.5 mm<sup>2</sup>, plus and minus poles are assigned to two terminals each (in parallel)

### Mechanical data

#### Mounting

by 4 screws M5

#### Mechanical dimensions

Mounting base pattern	110 x 110 mm (135 mm), see Fig. 11.2-2, Drilling
Height (depth if mounted on rear panel)	145 mm

#### Weight

4 kg

#### Cooling

The power supply unit must be mounted so that the convection air current is not disturbed.

#### Ambient temperature

max. 55 °C (at 100 % load)

#### Standards, regulations

VDE 0160, transformer according to VDE 0551

### Ordering data

Order number	07 NG 34 R1	GJV3 0756 02 R1
--------------	-------------	-----------------

## 11.3 Power Supply Unit 07 NG 35 R1

primary voltage: 230/400 V 3-phase AC, secondary voltage: 24 V DC, 10 A

The 07 NG 35 R1 power supply unit generates a 24 V DC voltage from a three-phase mains voltage of 230 V AC or 400 V AC. The output voltage is gained by using a 3-phase bridge-connected rectifier. Together with a filter capacitor, this guarantees a small ripple content of the voltage. The power supply unit has a load capability of 10 A. It is suitable for applications in electronic control systems. A green LED indicates that the output voltage is present.

The secondary voltage is protected by a built-in automatic circuit-breaker. The primary voltage (mains) has to be protected by external fuses.

The electrical connections are made via screw-type terminals. With 3-phase mains voltage of 230 V, the primary windings of the transformer are delta-connected, with 3-phase mains voltage of 400 V, the windings are star-connected (see Fig. 11.3-1). Cable grips fasten the cables. There is an electrical isolation between the primary and the secondary voltage according to VDE 0551 (safety electrical isolation).

The power supply is fastened by 4 screws M5 (see Fig. 11.3-2, Drilling pattern).

The power supply unit must be mounted so that the convection air current is not disturbed.

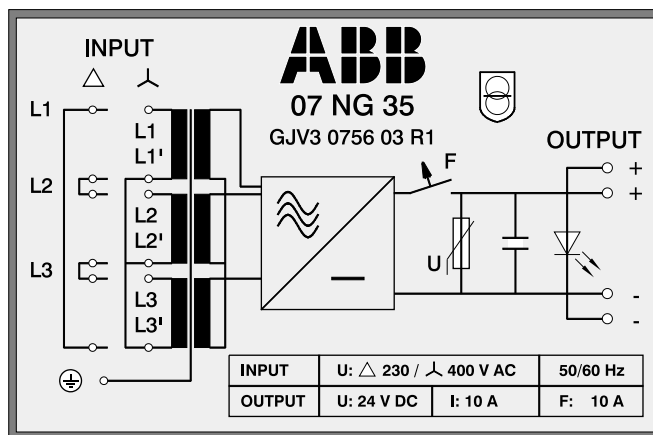

Configuration set by the factory:

230 V 3-phase AC

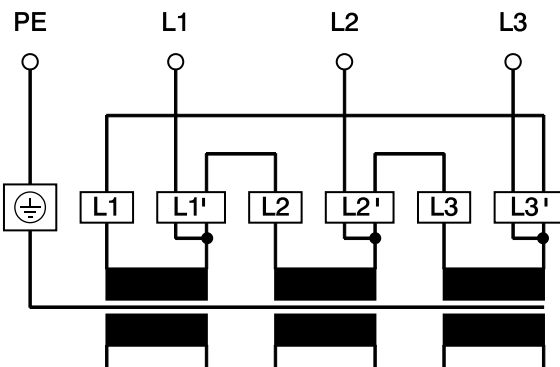

400 V 3-phase AC

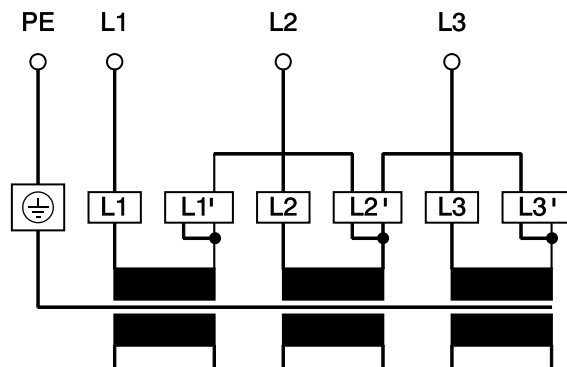
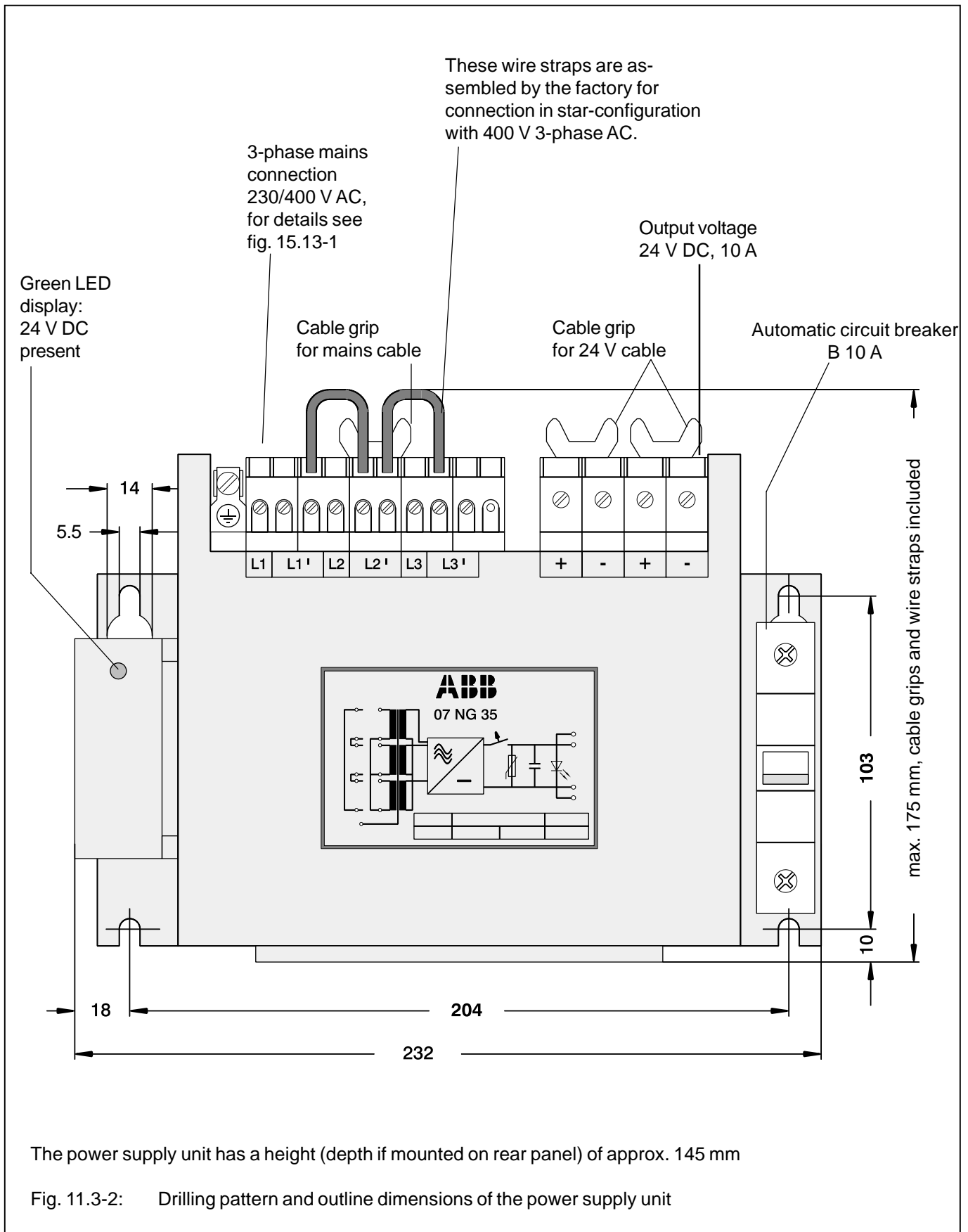

Fig. 11.3-1: Imprinted circuit diagram and terminal diagrams for 230 V und 400 V 3-phase AC





## Technical data

### Electrical data, input specifications

#### Primary voltage **230 V 3-phase AC**

Rated voltage		230 V 3-phase AC
Limiting values		207...253 V AC
Mains frequency		50 or 60 Hz
Current consumption	with no load	approx. 0.22 A
	with rated load	approx. 0.85 A
Fusing, primary		external

#### Primary voltage **400 V 3-phase AC**

Rated voltage		400 V 3-phase AC
Limiting values		360...440 V AC
Mains frequency		50 or 60 Hz
Current consumption	with no load	approx. 0.15 A
	with rated load	approx. 0.50 A
Fusing, primary		external

Max. conductor cross section of the terminals 2 x 1.5 mm<sup>2</sup>

### Electrical data, output specifications

#### Secondary voltage (output voltage)

Rated voltage	24 V DC
Limiting values	19.2...30 V DC
Max. ripple content	≤ 2 %
Indication "voltage present"	by green LED

#### Output load capability

Rated current (permitted continuous load) 10 A

#### Fusing, secondary

automatic circuit-breaker B 10 A

#### Max. conductor cross section of the terminals

2 x 4 mm<sup>2</sup>, plus and minus poles are assigned to two terminals each (in parallel)

### Mechanical data

#### Mounting

by 4 screws M5

#### Mechanical dimensions

Mounting base	232 x 175 mm, see Fig. 11.3-2, Drilling pattern
Height (depth if mounted on rear panel)	125 mm

#### Weight

6 kg

#### Cooling

The power supply unit must be mounted so that the convection air current is not disturbed.

#### Ambient temperature

max. 55 °C (at 100 % load)

#### Standards, regulations

VDE 0160, transformer according to VDE 0551

### Ordering data

Order number 07 NG 35 R1 GJV3 0756 03 R1

## 11.4 Power Supply Unit 07 NG 36 R1

primary voltage: 230/400 V 3-phase AC, secondary voltage: 24 V DC, 20 A

The 07 NG 36 power supply unit generates a 24 V DC voltage from a three-phase mains voltage of 230 V AC or 400 V AC. The output voltage is gained by using a 3-phase bridge-connected rectifier. Together with a filter capacitor, this guarantees a small ripple content of the voltage. The power supply unit has a load capability of 20 A. It is suitable for applications in electronic control systems. A green LED indicates that the output voltage is present.

The secondary voltage is protected by a built-in B-type automatic circuit-breaker. The primary voltage (mains) has to be protected by external fuses.

The electrical connections are made via screw-type terminals. With 3-phase mains voltage of 230 V, the primary windings of the transformer are delta-connected, with 3-phase mains voltage of 400 V, the windings are star-connected (see Fig. 11.4-1). Cable grips fasten the cables. There is an electrical isolation between the primary and the secondary voltage according to VDE 0551 (safety electrical isolation).

The power supply is fastened by 4 screws M6 (see Fig. 11.4-2, Drilling pattern).

The power supply unit must be mounted so that the convection air current is not disturbed.

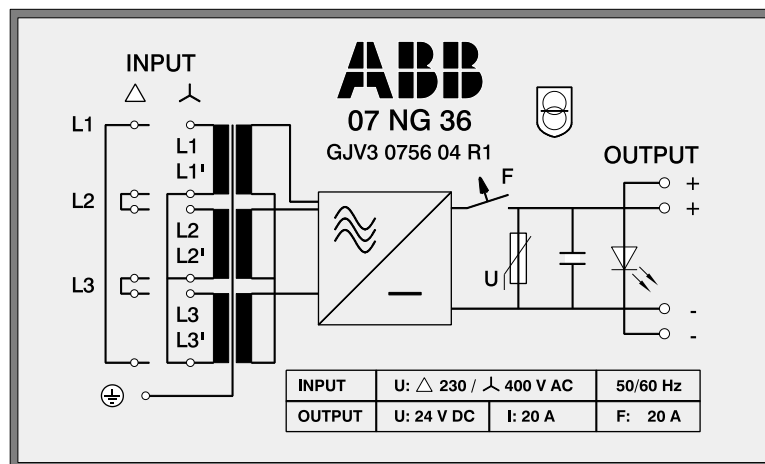

Configuration set by the factory:

230 V 3-phase AC

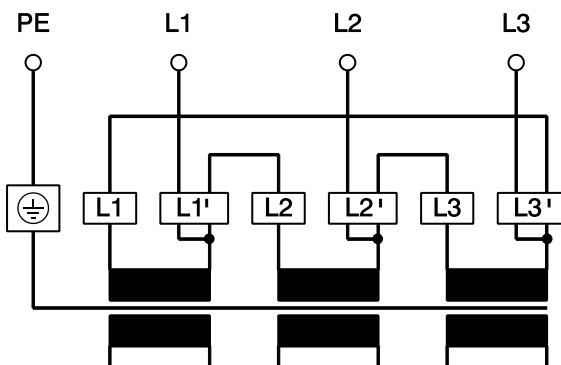

400 V 3-phase AC

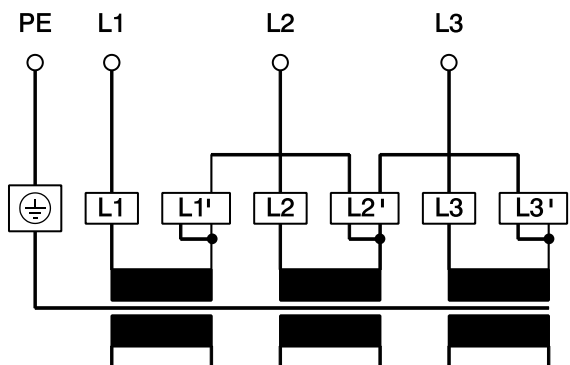

Fig. 11.4-1: Imprinted circuit diagram and terminal diagrams for 230 V and 400 V 3-phase AC

These wire straps are assembled by the factory for connection in star-configuration with 400 V 3-phase AC.

3-phase mains connection  
230/400 V AC,  
for details see  
fig. 15.14-1

Output voltage  
24 V DC, 20 A

Green LED  
display:  
24 V DC  
present

Cable grip  
for mains cable

Cable grip  
for 24 V cable

Automatic circuit breaker  
B 20 A

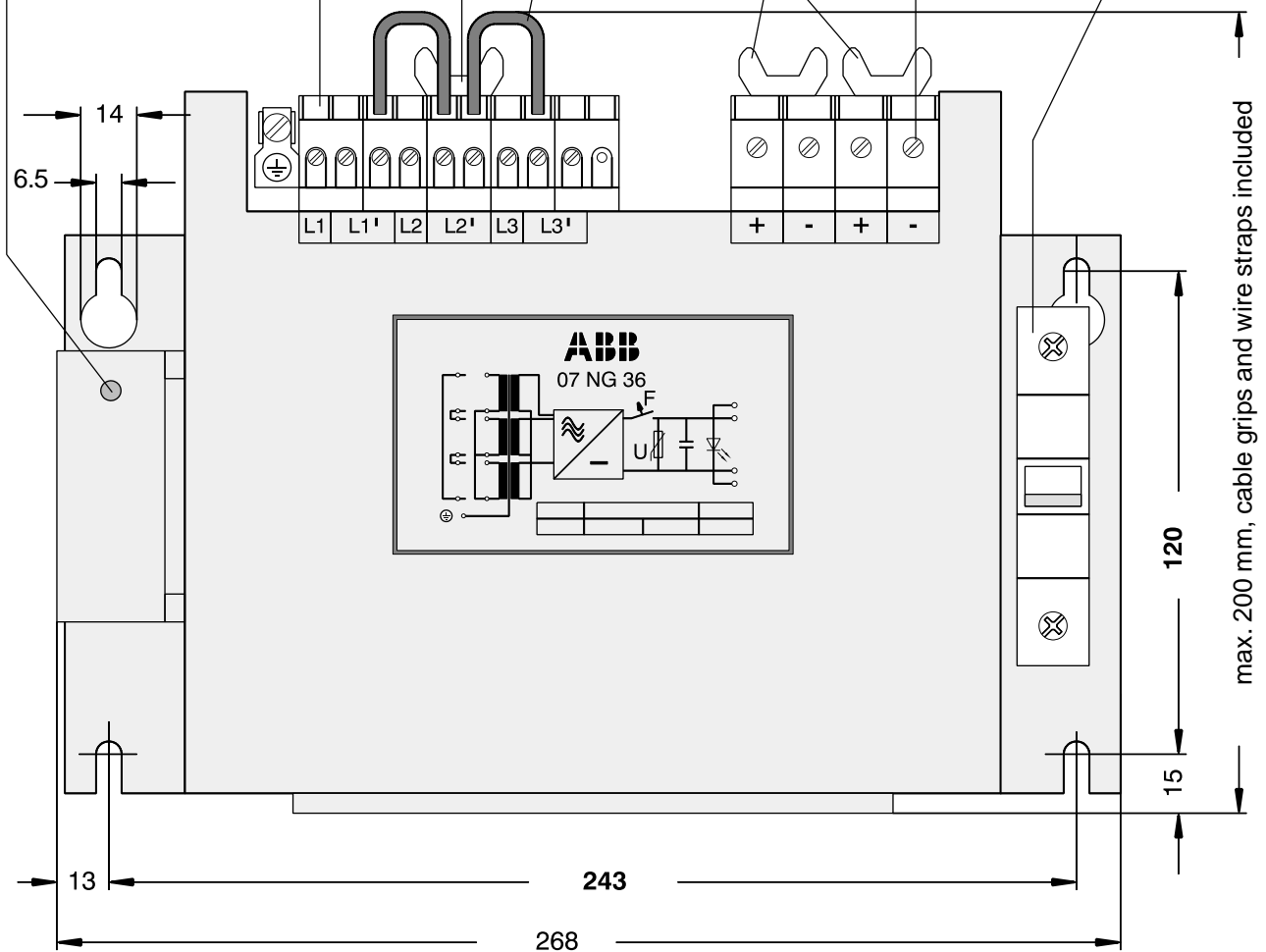

The power supply unit has a height (depth if mounted on rear panel) of approx. 136 mm

Fig. 11.4-2: Drilling pattern and outline dimensions of the power supply unit

## Technical data

### Electrical data, input specifications

#### Primary voltage **230 V 3-phase AC**

Rated voltage		230 V 3-phase AC
Limiting values		207...253 V AC
Mains frequency		50 or 60 Hz
Current consumption	with no load	approx. 0.35 A
	with rated load	approx. 1.70 A
Fusing, primary		external

#### Primary voltage **400 V 3-phase AC**

Rated voltage		400 V 3-phase AC
Limiting values		360...440 V AC
Mains frequency		50 or 60 Hz
Current consumption	with no load	approx. 0.25 A
	with rated load	approx. 1.00 A
Fusing, primary		external

Max. conductor cross section of the terminals 2 x 1.5 mm<sup>2</sup>

### Electrical data, output specifications

#### Secondary voltage (output voltage)

Rated voltage	24 V DC
Limiting values	19.2...30 V DC
Max. ripple content	≤ 2 %
Indication "voltage present"	by green LED

#### Output load capability

Rated current (permitted continuous load)	20 A
---	------

Max. conductor cross section of the terminals 2 x 4 mm<sup>2</sup>, plus and minus poles are assigned to two terminals each (in parallel)

### Mechanical data

Mounting by 4 screws M6

#### Mechanical dimensions

Mounting base	268 x 200 mm, see Fig. 11.4-2, Drilling pattern
Height (depth if mounted on rear panel)	136 mm

Weight 15 kg

Cooling The power supply unit must be mounted so that the convection air current is not disturbed.

Ambient temperature max. 55 °C (at 100 % load)

Standards, regulations VDE 0160, transformer according to VDE 0551

### Ordering data

Order number 07 NG 36 R1 GJV3 0756 04 R1

## 11.5 Lithium Battery Module 07 LE 90 R1 for use in processor units

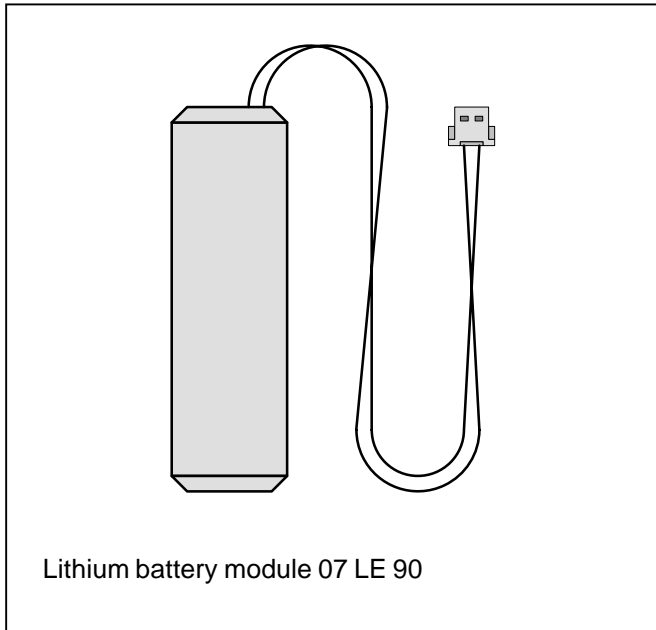

The following handling advice has to be taken into consideration:

- Use only genuine ABB lithium battery modules.
- At the end of lifetime, replace the battery module by a new one.
- **Do not short-circuit battery!** It may cause overheating or explosion. Prevent accidental short-circuit. Therefore, do not put battery into metallic boxes or on metallic surfaces.
- **Do not try to charge battery!** It may cause overheating or explosion!
- **Replace battery only during the power is on.** Otherwise you can loose data.
- **Dispose of the battery environmentally acceptable!**
- **Pay attention to the battery monitoring facilities on the devices, e.g.,**

The 07 LE 90 R1 lithium battery module is used for RAM data back-up in several processor units of programmable control systems. It is equipped with a 2-pole plug and two soldered wires.

LED indications, whether a battery is exhausted or missing. The battery lifetime depends on the unit where it is installed.

### Battery Lifetime

The value of the battery lifetime says how long the battery is able to back-up the stored data while the unit is not supplied by the internal voltages.

If the internal voltages are switched on, the battery is only discharged by its own leakage current.

Type of unit, where the battery is installed

Battery lifetime t (guaranteed values at 25°C)

07 KP 62 R101 (ABB Procontic T200)  
07 KP 63 R101 (ABB Procontic T200)  
07 KR 91 (Advant Controller 31)  
07 KT 9x (Advant Controller 31)

min. 5 000 h  
min. 5 000 h  
min. 4 200 h  
min. 4 200 h

### Technical Data

Capacity	1000 mAh
No-load voltage	3.6 V
Rated voltage	3.5 V
Temperature coefficient of rated voltage	approx. – 1 mV/K
Temperature coefficient of capacity	< – 1.5 % at 0...70 °C
Self discharge	< 3.0 % per year at 25 °C < 6.0 % per year at 40 °C < 25.0 % per year at 70 °C
Weight	20 g
Dimensions	18 mm x 53 mm
Order number	GJR5250700R1

## 11.6 SmartMedia Card 07 MC 90, inserted in 07 KT 95 to 07 KT 98

The SmartMedia Card serves for storing data up to 2 MB or 8 MB not being lost over an power OFF/ON cycle. It is used in the 07 KT 95...98 and 07 SL 97 basic units. It is recommended only to use ABB-proven SmartMedia Cards.

### Field of application

- Storing and loading of PLC programs
- Storing and loading of user data
- Loading of firmware updates

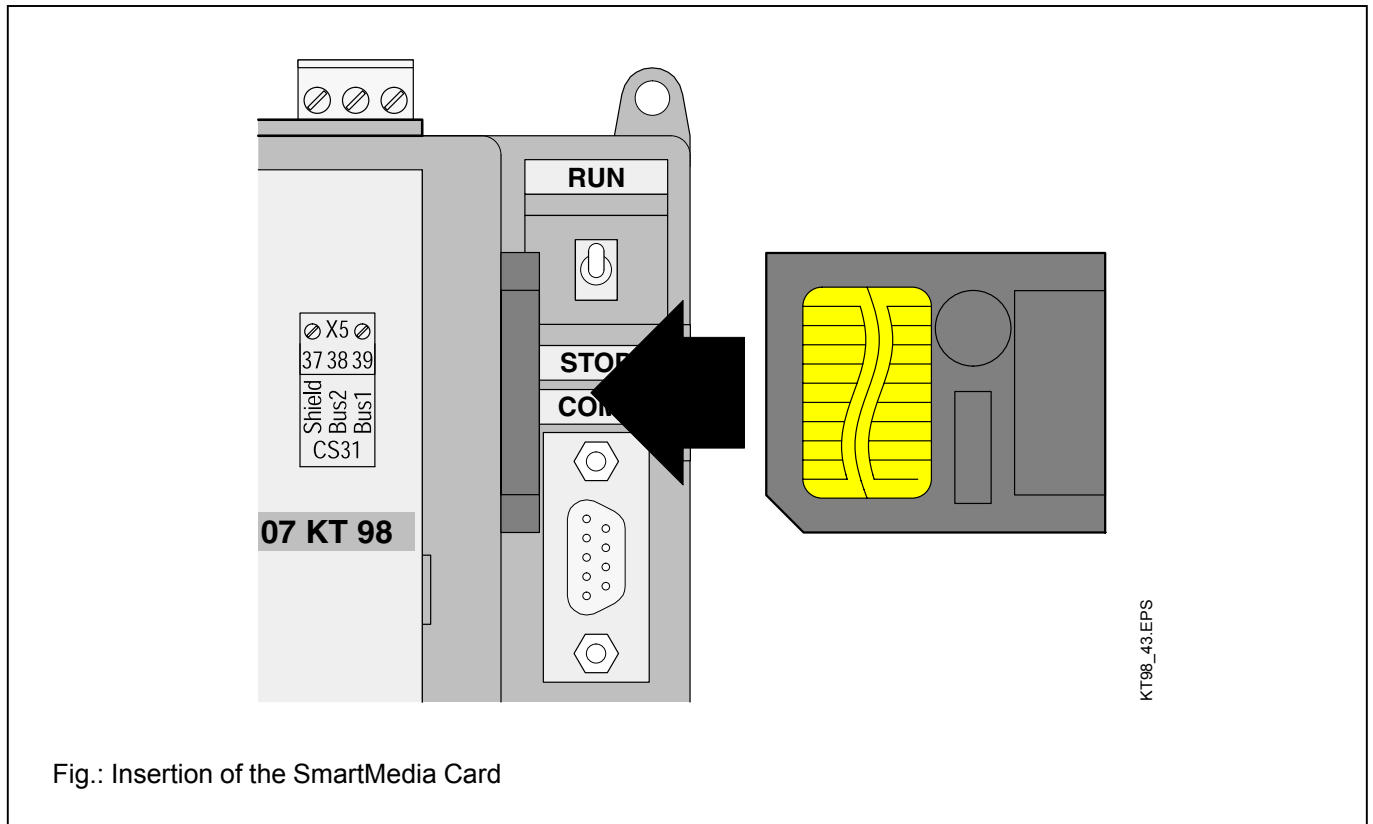

### Handling instructions

- The SmartMedia Card is inserted with the contact field visible (see the figure above).
- A SmartMedia Card, once initialized as user data memory, can no more be used as a user program card.
- The SmartMedia Card must be protected from
  - mechanical stress (e.g. do not bend)
  - electrostatic discharge
  - contact pollution (do not touch the contacts)

### Important note

SmartMedia Cards with a supply voltage of 3.3 V cannot be used with basic units of the versions R01xx. They also cannot be used with 07 SL 97 basic units (see Usability).

### Access

- Access within the PLC program is possible with function blocks, see documentation of the programming software.

### Usability

SmartMedia Card 07 MC 90 **5 V** GJR5 2526 00 **R0101** (supply voltage 5 V, usable with the basic units 07 SL 97, 07 KT 95 to 07 KT 98 **R 01xx** and **R02xx**, all firmware versions, memory capacity 2 MB)

SmartMedia Card 07 MC 90 **3,3 V** GJR5 2526 00 **R0201** (supply voltage 3.3 V, usable with the basic units 07 KT 95 to 07 KT 98 **R02xx** with firmware versions as of V5.0, memory capacity 8 MB)

### Technical data

Weight	2 g
Dimensions	45 x 37 x 0.7 mm

### Order numbers

07 MC 90	5 V	2 MB	GJR5 2526 00 <b>R0101</b>
07 MC 90	3.3 V	8 MB	GJR5 2526 00 <b>R0201</b>

## 11.7 SmartMedia Card 07 MC 90, inserted in 07 SL 97

The SmartMedia Card serves for storing data up to 2 MB to protect them against being lost while the power is off. It is inserted into the basic unit 07 SL 97. It is recommended only to use ABB-proven SmartMedia Cards.

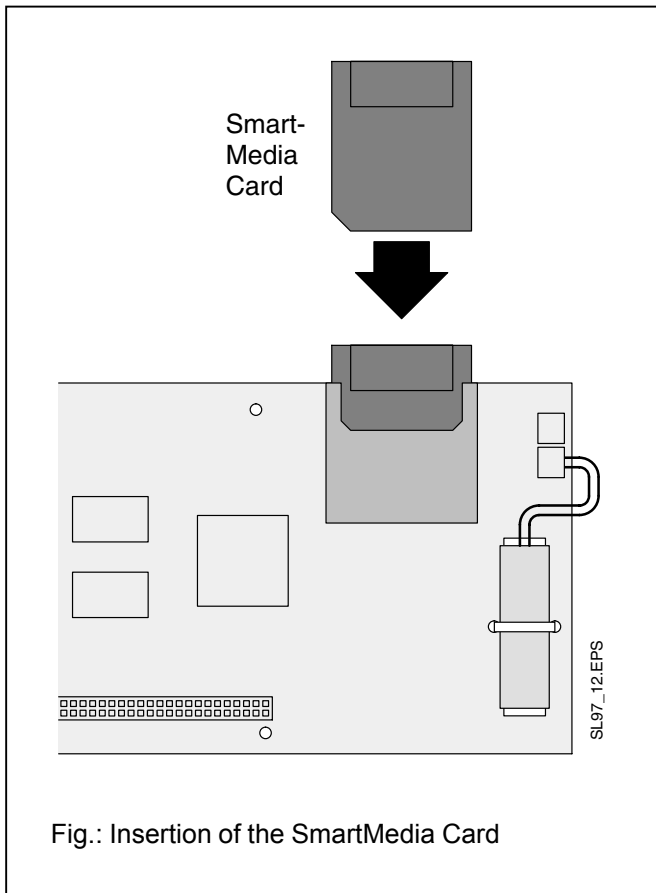

### Field of application

- Storing and loading of PLC programs
- Storing and loading of user data
- Loading of firmware updates

### Handling instructions

- **Observe the instructions of the PC manufacturer before opening the PC housing!**
- Insert or remove the SmartMedia Card only with the slot PLC switched off.
- The SmartMedia Card must be inserted with the contact field upwards (contacts are visible, see figure above).
- After a SmartMedia Card has been initialized once as user data memory it cannot be used any more as an user program card.
- The SmartMedia Card has to be protected against
  - mechanical damages (e.g. do not bend)
  - electrostatic discharge
  - contact pollution (do not touch the contacts)

### Important note

SmartMedia Cards with a supply voltage of 3.3 V, e.g. GJR5 2526 **R0201**, cannot be used with 07 SL 97 basic units.

### Access

- The SmartMedia Card can be accessed within the PLC program via function blocks. Refer to the documentation of the programming software 907 AC 1131.

### Technical data

Weight 2 g

Dimensions 45 x 37 x 0.7 mm

Order number

07 MC 90 5 V 2 MB GJR5 2526 00 **R0101**







---

**ABB STOTZ-KONTAKT GmbH**

Eppelheimer Straße 82 Postfach 101680  
69123 Heidelberg 69006 Heidelberg  
Germany Germany

Telephone +49 6221 701-0  
Telefax +49 6221 701-240  
E-Mail [desst.help@de.abb.com](mailto:desst.help@de.abb.com)  
Internet <http://www.abb.de/stotz-kontakt>