

General Specifications

Model VP6P6900, VP6P6910,
VP6P6920, VP6P6930
SEM Sequence of Events Manager



GS 33J30D10-01EN

[Release 6]

GENERAL

This GS (General Specifications) describes the specifications of the Sequence of Events Manager (SEM). The SEM captures, records and displays in chronological order the sequence of events (SOE) prior to and during a plant trip. The SEM provides a means of recording activities leading to a potential plant upset or trip.

The SEM offers the following benefits:

- High-speed capturing of events with one millisecond time stamp resolution
- SOE inputs available for use as control and or monitoring signals
- Accurate system time synchronization across a Vnet/IP system without additional hardware
- Time synchronization with Simple Network Time Protocol (SNTP) server (Option)
- Trip Report for a specified time period upon occurrence of user defined triggers
- Long-term data storage and automatic trip report generation
- SOE data output to OPC clients (e.g. Exaquantum)
- SOE viewing and reporting at multiple Human Interface Stations (HIS) and/or any other computers via Ethernet
- SOE viewing and reporting that integrate SOE messages with process alarms and other process related events

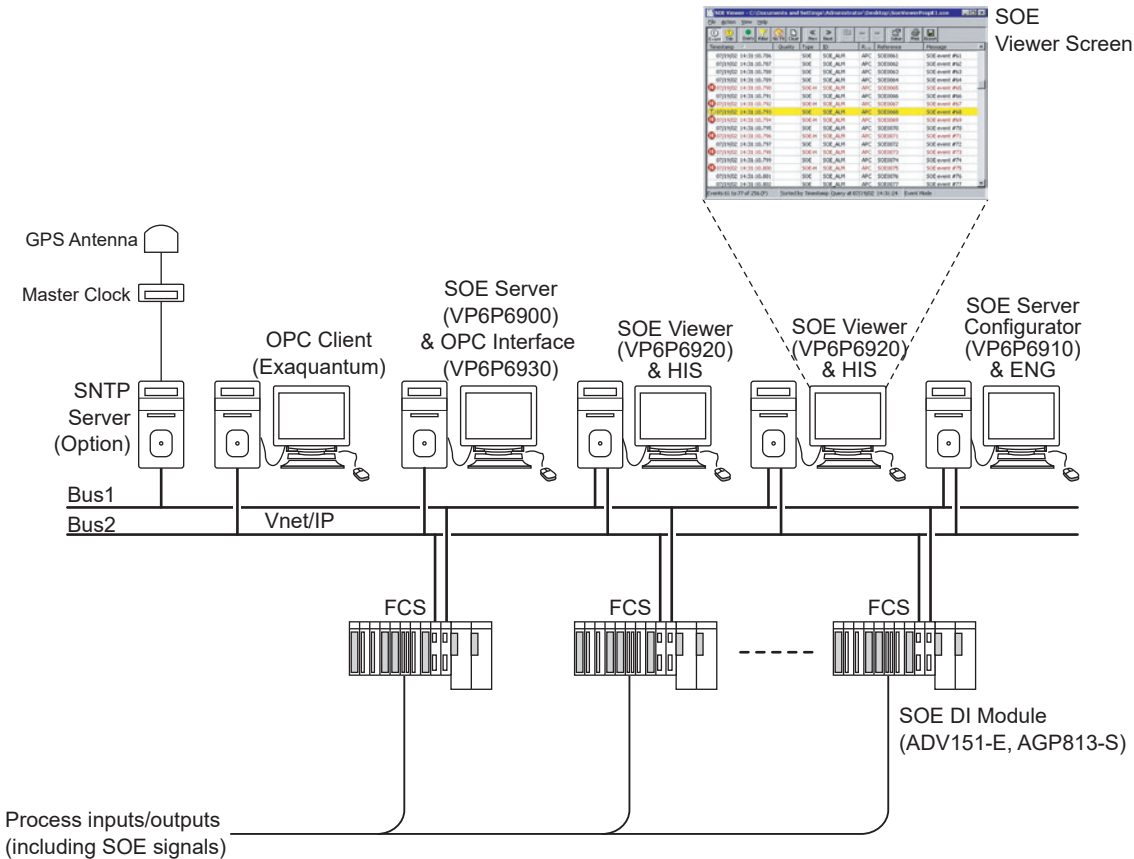

Figure: Example of SEM System Basic Configuration

F01E.ai

■ SYSTEM COMPONENTS AND SOFTWARE

The SEM is designed to capture incoming sequences of events from digital input channels. These modules apply time stamp and send the SOE data from the Field Control Station to the SOE Server via Vnet/IP. An open communication bus of Vnet/IP is used for SOE data transmission. The SOE data is sent to the SOE Server, stored in the SOE Server and displayed in chronological order on the SOE Viewer screen. As the SEM employs a Server/Client (Viewer) architecture, the SOE data stored in the SOE Server can be easily accessed from multiple HISs and/or any other computers via Vnet/IP. The SEM consists of the following system components with the appropriate SEM software.

● Field Control Station

The following FCS models can provide an interface to transfer time-stamped SOE data from SOE digital input modules to the SOE Server.

- A2FV50S Field Control Unit (for Vnet/IP and N-IO/FIO, 19-inch Rack Mountable Type)
- A2FV50D Duplexed (for Vnet/IP and N-IO/FIO, 19-inch Rack Mountable Type)
- AFV30S Field Control Unit (for Vnet/IP and FIO, 19-inch Rack Mountable Type)
- AFV30D Duplexed Field Control Unit (for Vnet/IP and FIO, 19-inch Rack Mountable Type)
- AFV40S Field Control Unit (for Vnet/IP and FIO, with Cabinet)
- AFV40D Duplexed Field Control Unit (for Vnet/IP and FIO, with Cabinet)
- AFV10S Field Control Unit (for Vnet/IP and FIO, 19-inch Rack Mountable Type)
- AFV10D Duplexed Field Control Unit (for Vnet/IP and FIO, 19-inch Rack Mountable Type)

For the specifications of these models, see the “Hardware Specifications” of GS 33J62E10-01EN, GS 33J60E10-01EN, GS 33J60E20-01EN, and GS 33K50E30-50E.

● SOE Digital Input Modules (Models: ADV151-E, AGP813-S, A2MMM843-S, and A2MDV843-S)

The I/O modules and numbers of their channels that can be used as SOE input points are as follows:

- ADV151-E: 32 channels
- AGP813-S: 8 channels
- A2MMM843-S: 16 channels (when all 16 channels are configured as digital input channels)
- A2MDV843-S: 16 channels (the same as above)

● SOE Server (Model: VP6P6900)

The SOE Server is designed to acquire and store SOE data from multiple FCSs and make available this data to multiple HIS or computers running SOE Viewer software. The SOE Server is configured in a dedicated server computer connected to an Ethernet or an open communication bus (Bus 2) of Vnet/IP. The SOE Server can also be configured in an HIS under the some conditions specified in “■ SPECIFICATIONS OF SOE SERVER”. Microsoft SQL Server is used for database management.

● SOE Viewer (Model: VP6P6920)

The SOE Viewer is designed to access and query the SOE Server. It displays the SOE data with filtering as specified by the user. The SOE Viewer generates and prints trip reports, and exports them to CSV (comma-separated value) format files. The SOE data from other data sources, such as messages stored in HISs, can also be displayed on the SOE Viewer. Each SOE point can be viewed with its associated time stamp, alarm class, equipment name, event message along with other configured in formation.

Timestamp	Quality	Type	ID	R...	Reference	Message
07/19/02 14:31:10.786		SOE	SOE_ALM	APC	SOE0061	SOE event #61
07/19/02 14:31:10.787		SOE	SOE_ALM	APC	SOE0062	SOE event #62
07/19/02 14:31:10.788		SOE	SOE_ALM	APC	SOE0063	SOE event #63
07/19/02 14:31:10.789		SOE	SOE_ALM	APC	SOE0064	SOE event #64
07/19/02 14:31:10.790	H	SOE-H	SOE_ALM	APC	SOE0065	SOE event #65
07/19/02 14:31:10.791		SOE	SOE_ALM	APC	SOE0066	SOE event #66
07/19/02 14:31:10.792	H	SOE-H	SOE_ALM	APC	SOE0067	SOE event #67
07/19/02 14:31:10.793	T	SOE	SOE_ALM	APC	SOE0068	SOE event #68
07/19/02 14:31:10.794	H	SOE-H	SOE_ALM	APC	SOE0069	SOE event #69
07/19/02 14:31:10.795		SOE	SOE_ALM	APC	SOE0070	SOE event #70
07/19/02 14:31:10.796	H	SOE-H	SOE_ALM	APC	SOE0071	SOE event #71
07/19/02 14:31:10.797		SOE	SOE_ALM	APC	SOE0072	SOE event #72
07/19/02 14:31:10.798	H	SOE-H	SOE_ALM	APC	SOE0073	SOE event #73
07/19/02 14:31:10.799		SOE	SOE_ALM	APC	SOE0074	SOE event #74
07/19/02 14:31:10.800	H	SOE-H	SOE_ALM	APC	SOE0075	SOE event #75
07/19/02 14:31:10.801		SOE	SOE_ALM	APC	SOE0076	SOE event #76
07/19/02 14:31:10.802		SOE	SOE_ALM	APC	SOE0077	SOE event #77

Figure: SOE Viewer Screen

F02E.ai

● SOE Server Configurator (Model: VP6P6910)

The SOE Server Configurator is designed to configure the SOE Server. The Configurator is used to define various settings such as the station configuration, SOE input terminals and the trip report configuration.

● SEM OPC Interface (Model: VP6P6930)

The SEM provides the OPC interface function which OPC clients such as Exaquantum can access the SOE data stored in the SOE server through Ethernet. The OPC interface works as an OPC Alarm and Events (A&E) server and an OPC Historical Data Access (HDA) server.

● Human Interface Stations (HISs)

Using the SOE Viewer Software an HIS can be used to access the SOE data stored in a SOE Server via Vnet/IP. The status of SOE modules, ADV151-E/AGP813-S can be displayed on the Station Status Display window of the HIS.

● Vnet/IP Network

The CENTUM VP system synchronizes the system time across Vnet/IP using own time synchronization protocol. When the time synchronization with an external master clock is required, the Vnet/IP system allows connection with a Simple Network Time Protocol (SNTP) server. A SNTP server incorporating a Global Positioning System (GPS) receiver or similar is used for more accurate time reference.

■ SYSTEM SPECIFICATIONS

Number of SOE inputs: Up to 2048 points per SOE Server

Number of SOE Servers: One server per SEM system

Number of FCSs per SOE Server: Up to 32

Number of ADV151-E: Up to 78 modules per FCS with VP6F1550 Node Expansion Package Up to 110 modules
FCS

Number of AGP813-S: Up to 8 modules including ALR111/ALR121/ALE111/ALP111/ALP121 (*1)
/A2LP131/AGS813/AGP813 per FCS.

Number of Events retained in CP471/CP461/CP451 event buffer: Up to 10,000 events

Number of Events retained in ADV151-E event buffer: Up to 512 events per two seconds

Number of Events retained in AGP813-S event buffer: Up to 256 events per two seconds

Time stamp resolution: One millisecond (*2)

Time-stamp delay compensation setting: Zero to 100 milliseconds

Automatic event deletion: Selection from among 15 options from no auto-deletion to auto-deletion of the five oldest events occurring within the last 3.5 seconds.

Software filter setting: 4 to 512 milliseconds (can be set increments of two milliseconds).

*1: ALP111 and ALP121 cannot be mounted in the same FCS.

*2: The time stamp resolution within the same domain is ± 1 ms. However, this applies to events from an I/O module installed within a 4 km distance from the CPU node. The time stamp resolution when using an ESB bus optical repeater module for an extended distance of up to 50 km is ± 3 ms.

When the number of SOE inputs or FCSs exceeds the limitations for a single SEM system, multiple SEM systems can be installed, up to eight servers.

The SOE Viewers can access the SOE stored data from multiple SOE Servers via Ethernet and display the SOE data on a single SOE Viewer window.

■ SPECIFICATIONS OF SOE SERVER

SOE Server (*1):

Dedicated server for the installation of SOE Server, SOE Viewer and SOE Server Configurator packages. It is not allowed to install any CENTUM VP software packages other than SOE software packages.

Event acquisition rate:

Up to 2000 events per second in AFV10□

Up to 4000 events per second in AFV30□/AFV40□, and A2FV50□

Number of Clients for SOE Viewer and SOE Server Configurator:

Up to the number allowed by the licenses purchased for Microsoft SQL Server 2005/2008/2008 R2/2012/2014/2016, and Microsoft Windows Server 2016

Database capacity:

A disk size of 200 MB is required for retaining 365,000 historical events, assuming 1,000 events per day for one year.

Microsoft SQL Server is used as a database management system. The database capacity is limited by the hard disk capacity except for the following Microsoft SQL Server.

- 4 GB for SQL Server 2005 Express Edition and SQL Server 2008 Express with Tools.
- 10 GB for SQL Server 2008 R2 Express with Management Tools, SQL Server 2012 Express with Tools, SQL Server 2014 Express with Tools, and SQL Server 2016 Express.

*1: When the conditions for "Installation in an HIS" in the following are met, SOE Server can be resided in HIS.

● Installation in an HIS

The SOE server packages are allowed to reside an HIS under the following conditions.

Total number of SOE inputs: Up to 512 points

Event acquisition rate: Up to 500 events per second

Computer Operating system for HIS: See "Table Compatibilities of SQL Servers and Operating Systems" in "● Software Requirements".

Database management system: SQL Server 2005 Express Edition, SQL Server 2008 Express with Tools, SQL Server 2008 R2 Express with Management Tools, SQL Server 2012 Express with Tools, SQL Server 2014 Express with Tools, or SQL Server 2016 Express. Refer to the "Database capacity" as described above.

Other specifications for SEM and HIS: Same specifications as standard

■ SPECIFICATIONS OF SOE VIEWER

Number of data acquisition sources: Up to eight data sources or up to eight SOE Servers

Data acquisition source types: SOE Server, historical messages in HIS, Unified Operator Interface (UOI) messages

Number of events displayed: Up to 99,999 events

Display items in the SOE Viewer screen:

Time stamp: Date and time of occurrence of the corresponding event signal

Quality: Single letter indicating the time synchronization state at the event occurrence

Type: Importance level of the corresponding event, either "SOE" (ordinary) or "SOE-H" (important)

ID: Either "SOE_ALM" (occurrence of the alarm state) or "SOE_RTN" (return to normal state)

Resource: Equipment name (plant hierarchy name) associated with the corresponding SOE event signal

Reference: Reference number (tag name) of the corresponding SOE event signal

Message: Message text of the corresponding SOE event signal

■ SPECIFICATIONS OF SOE SERVER CONFIGURATOR

Number of SOE input assignments: Selection from 128, 512, and 2048 input points

Number of Trip trigger assignments: Up to 50 triggers

■ NETWORKING SPECIFICATIONS

The SEM uses an open communication network adopting IEEE802.3 standards on the bus 2 of Vnet/IP for SOE Server, SOE Viewers and SOE Server Configurator.

When the Simple Network Time Protocol (SNTP) server is required for the time synchronization with an external master clock, the server can be also connected on the bus 1 of Vnet/IP.

For the networking specifications of SEM, see the "Vnet/IP network specifications" of "Integrated Control System CENTUM VP System Overview (GS 33J01A10-01EN)".

■ OPERATING ENVIRONMENT

● Hardware Requirements

SOE Server

The SOE Server function runs on a computer which meets the following requirements:

- Computer: A personal computer following the basic specifications of HIS.
For details of HIS, see GS 33J05D10-01EN.
- Hard disk: Refer to the “Database capacity” in the “■ SPECIFICATIONS OF SOE SERVER”
- Network: One Ethernet network or the bus2 of Vnet/IP for the SOE Server.
For details of Vnet/IP network specifications, see GS 33J01A10-01EN.
Vnet/IP Interface Card (VI702) is not required when the SOE server does not work on Vnet/IP.
- Peripherals: DVD drive
Tape drive for data backup (optional)

SOE Viewer and/or SOE Server Configurator

- Computer: A personal computer following the basic specifications of HIS.
For details of HIS, see GS 33J05D10-01EN.
- Network: One Ethernet network on the bus2 of Vnet/IP for the SOE Server.
For details of Vnet/IP network specifications, see GS 33J01A10-01EN.
- Peripherals: DVD drive

Other Components

- A2FV50□: Field Control Unit.
- AFV30□: Field Control Unit.
- AFV40□: Field Control Unit.
- AFV10□: Field Control Unit. Style 2 or later (Style No. is indicated on the component tag)
- EC402: ESB Bus Coupler Module.
- EC401: ESB Bus Coupler Module. Style 2 or later (Style No. is indicated on the component tag)
- VI702: Vnet/IP Interface Card.
- AVR10D: Duplexed V net Router. Firmware revision of VI451 should be R6 or later
(Firmware revision No. is indicated under “F2” on the revision sticker on the component)

● Software Requirements

SOE Server

Database management system and operating system:

When Microsoft SQL Server 2014 or earlier is applied, 32-bit version must be used even on 64-bit operating system. As for Microsoft SQL Server 2016, only 64-bit version is available, and it is applicable.

Table Compatibilities of SQL Servers and CENTUM VP

SQL Server CENTUM VP	Microsoft SQL Server 2005	Microsoft SQL Server 2008	Microsoft SQL Server 2008 R2	Microsoft SQL Server 2012	Microsoft SQL Server 2014	Microsoft SQL Server 2016
	SP4	SP4	SP2/SP3	SP1/SP2/SP3	SP1/SP2	SP1/SP2
R6.01.00/R6.01.10	X	X	X	X (SP1)	—	—
R6.02.00	—	X	X	X (SP1/SP2)	X (SP1)	—
R6.03.00/R6.03.10	—	X	X	X	X (SP1)	—
R6.04.00	—	X	X	X	X	—
R6.05.00	—	X	X	X	X	—
R6.06.00	—	X	X	X	X	X (SP1)
R6.07.00/R6.07.10	—	—	—	X	X	X

X: Compatible —: Incompatible

Note: Service Pack is abbreviated as SP (Example: SP1 stands for Service Pack 1).

Table Compatibilities of SQL Servers and Operating Systems

SQL Server \ Operating system		Windows Vista Business	Windows 10 Enterprise 2016 LTSB (*5)	Windows Server 2016 Standard
		32-bit	64-bit	64-bit
		SP2	without SP	without SP
Microsoft SQL Server 2005 (*1)	Enterprise	—	—	—
	Standard	X	—	—
	Workgroup	X	—	—
	Express	X (*3)	—	—
Microsoft SQL Server 2008	Enterprise	—	—	—
	Standard	X	—	—
	Workgroup	X	—	—
	Express with Tools	X (*3)	—	—
Microsoft SQL Server 2008 R2	Datacenter	—	—	—
	Enterprise	—	—	—
	Standard	X	—	—
	Workgroup	X	—	—
	Express with Management Tools	X (*3)	—	—
Microsoft SQL Server 2012	Enterprise	—	—	—
	Business Intelligence	—	—	—
	Standard	X	—	—
	Express with Tools	X (*4)	—	—
Microsoft SQL Server 2014 (*2)	Enterprise	—	—	—
	Business Intelligence	—	—	—
	Standard	—	X	—
	Express with Tools	—	X	—
Microsoft SQL Server 2016 (*6)	Enterprise	—	—	X
	Standard	—	X	X
	Express	—	X (*3)	X (*3)

X: Compatible —: Incompatible

Note: Service Pack is abbreviated as SP (Example: SP1 stands for Service Pack 1).

*1: CENTUM VP R6.01 supports SQL Server 2005 SP2, SP3, SP4, but R6.02 or later does not.

*2: CENTUM VP R6.02 or later supports SQL Server 2014, but R6.01 does not.

*3: SOE Server function can be resided with HIS when the maximum number of acquisition points is 512 or less, and the number of HIS on the same network with the SOE Server is 20 or less. Be sure to use Express Edition which SOE function supports in SQL version.

*4: SQL Server 2012/2014 Express with Tools cannot be resided with HIS.

*5: Windows 10 IoT Enterprise 2016 LTSB is also supported. CENTUM VP R6.04 or later works on Windows 10. SQL Server is running in Wow64 environment.

*6: CENTUM VP R6.06 or later supports SQL Server 2016.

SOE software packages:
 VP6P6900 SOE Server Package
 VP6P6910 SOE Server Configurator Package
 VP6P6920 SOE Viewer Package
 VP6P6930 SEM OPC Interface Package

For R6.01.00 or later, revision of SOE Server, SOE Server Configurator, and SOE Viewer must be the same.

SOE Server, SOE Server Configurator, SOE Viewer, and SEM OPC Interface can reside in a single computer.
 SOE Server, SOE Server Configurator, SOE Viewer, and SEM OPC Interface can reside in a single HIS if the total number of SOE samples is limited.
 SEM OPC Interface must be resided in a single computer or an HIS equipped with the SOE Server.
 SOE Server Configurator and SOE Viewer can be used in a computer or an HIS equipped with or without the SOE Server.

For CENTUM VP R6.06 or later, it is recommended to use SQL Server 2016, but SQL Server 2008/2008 R2/2012/2014 can be used only at the time of upgrading. To use SQL Server 2008/2008 R2/2012/2014, please install .NET Framework 3.5. If .NET Framework 3.5 is not installed please install it. Refer to the table below for the compatibilities of SQL Server and Operating Systems.

Table compatibilities of SQL Server and Operating Systems during upgrading

Microsoft SQL Server	Windows 10 Enterprise 2016 LTSB (*1)	Windows Server 2016 Standard
2008	—	—
2008 R2	—	—
2012	—	—
2014	X (*2)	—
2016	X	X

- *1: Windows 10 IoT Enterprise 2016 LTSB is also supported. CENTUM VP R6.04 or later works on Windows 10. SQL Server is running in Wow64 environment.
- *2: It's available only when upgrading.

The number of client licenses to be purchased for Microsoft SQL Server 2005/2008/2008 R2/2012/2014/2016 and Microsoft Windows Server 2016 is determined by counting the number of clients (SOE Viewers and SOE Server Configurator) to be connected to the SOE Server.

SOE Viewer and/or SOE Server Configurator

Operating system: Follow the requirements for the HIS.
 SOE software packages:
 VP6P6910 SOE Server Configurator Package
 VP6P6920 SOE Viewer Package

HIS

One OPC package is required for receiving the SOE Server system messages on to the HIS.
 OPC software package: VP6H2411 Exaopc OPC Interface Package

For the general specifications of the HIS, see GS 33J05D10-01EN.

■ LIMITATION OF INSTALLATION AND NOTICES

● Limitations of ADV151-E/AGP813-S Installation

The ADV151-E/AGP813-S is not allowed to install in the ER bus node unit. The SOE capture function of ADV151-E/AGP813-S can be used only when it is installed in the ESB bus node unit and optical ESB bus node unit.

See General Specifications GS 33J60F70-01EN “Digital I/O Modules (for FIO)” and GS 33J60A10-01EN “FIO System Overview (for Vnet/IP)” for other limitations and precautions for installation.

■ MODEL AND SUFFIX CODES

Digital Input Module with SOE Capture

		Description
Model	ADV151	Digital Input Module (32-channel, 24 V DC, Isolated)
Suffix Codes	-E	With SOE capture
	5	Without status display; with no explosion protection
	6	With status display; with no explosion protection
	E	Without status display; with explosion protection
	F	With status display; with explosion protection
	0	Basic type
	3	With ISA Standard G3 option and temperature (-20°C to 70°C) option
Option Codes	/D5A00	With KS Cable Interface Adapter for 32-channel Digital Input [Model: ATD5A-00]
	/B5S00	With Pressure Clamp Terminal Block for Digital Input [Model: ATB5S-00]
	/B5S10	With Pressure Clamp Terminal Block for Digital Input (surge absorber) [Model: ATB5S-10]
	/B5D00	With Dual Pressure Clamp Terminal Block for Digital Input [Model: ATB5D-00]
	/B5D10	With Dual Pressure Clamp Terminal Block for Digital Input (surge absorber) [Model: ATB5D-10]
	/CCC01	With Connector Cover for MIL Cable [Model: ACCC01]

SOE Server Package

		Description
Model	VP6P6900	SOE Server Package
Suffix Codes	-V	Software license
	-E	For Expansion
	1	Always 1
	1	English version
	N01	Total number of SOE input point is 128 or less
	N05	Total number of SOE input point is 512 or less
	N09	Total number of SOE input point is 2048 or less
	N15	From (128 SOE inputs or less) to (512 SOE inputs or less)
	N19	From (128 SOE inputs or less) to (2048 SOE inputs or less)
	N59	From (512 SOE inputs or less) to (2048 SOE inputs or less) (*3)

Note: This package is able to run in the computer with Microsoft Windows Server.

Note: This package uses Microsoft SQL Server for the database.

Note: When ordering this license newly, estimate the total number of SOE input point and be sure to select '-V' and the type of it from 'N01' to 'N09' in the suffix codes. Up to the specified number of the points can be operated and monitored.

Note: When increasing the total number of SOE input points, be sure to select '-E' and the type of increased IO points from 'N15' to 'N59' in the suffix codes.

SOE Server Configurator Package

		Description
Model	VP6P6910	SOE Server Configurator Package
Suffix Codes	-V	Software license
	1	Always 1
	1	English version

Note: This package is able to run in the HIS, SOE Server, Builder computer or computer.

SOE Viewer Package

		Description
Model	VP6P6920	SOE Viewer Package
Suffix Codes	-V	Software license
	1	Always 1
	1	English version

Note: This package is able to run in the HIS, SOE Server, Builder computer or computer.

SEM OPC Interface Package

		Description
Model	VP6P6930	SEM OPC Interface Package
Suffix Codes	-V	Software license
	1	Always 1
	1	English version

Note: This package must be resided in a single computer or an HIS equipped with the SOE Server.

Note: This package provides an OPC server function used for sending SOE events to an OPC client such as Exaquantum.

■ ORDERING INFORMATION

Specify the model and suffix codes when ordering.

■ TRADEMARKS ACKNOWLEDGMENT

The names of corporations, organizations, products and logos herein are either registered trademarks or trademarks of Yokogawa Electric Corporation and their respective holders.