

Trusted Power System

Product Overview

The Trusted® Power System is a high density flexible power supply designed to convert main line voltages of either 110 Vac or 240 Vac. Outputs are either 24 Vdc for Trusted product or 28 Vdc adjustable field power.

The Trusted Power System consists of a 1U Power Shelf with mechanical support, containing up to three 750 W Power Packs. The Power Packs load share in configurations using one or more Power Shelves. Each Power Pack has an individual supply connection via a mechanically retained IEC 60320 type connector. Each Power Shelf can supply 2250 W of power or 1500 W with n+1 redundancy from a single source. Multiple units can be connected for further capacity or redundancy requirements.

Diagnostic information of Power Pack status is provided via the Power Port, which connects to the rear of the Power Shelf. This device monitors input and output conditions and reports out of range faults and over-temperature/fan failure using relay contacts. The Power Port also allows connection of the optional rack mounted Power Controller for live configuration, of output voltage and current, monitoring up to 12 Power Packs in 4 Power Shelves.

Features:

- Redundant and N+1 configurations.
- Hot replaceable Power Packs.
- Current sharing.
- Current limiting.
- Power factor correction.
- Diagnostic contacts.
- Configurable output voltage.
- Input/output fail diagnostics per power pack.

Page intentionally left blank

PREFACE

In no event will Rockwell Automation be responsible or liable for indirect or consequential damages resulting from the use or application of this equipment. The examples given in this manual are included solely for illustrative purposes. Because of the many variables and requirements related to any particular installation, Rockwell Automation does not assume responsibility or reliability for actual use based on the examples and diagrams.

No patent liability is assumed by Rockwell Automation, with respect to use of information, circuits, equipment, or software described in this manual.

All trademarks are acknowledged.

DISCLAIMER

It is not intended that the information in this publication covers every possible detail about the construction, operation, or maintenance of a control system installation. You should also refer to your own local (or supplied) system safety manual, installation and operator/maintenance manuals.

REVISION AND UPDATING POLICY

This document is based on information available at the time of its publication. The document contents are subject to change from time to time. The latest versions of the manuals are available at the Rockwell Automation Literature Library under "Product Information" information "Critical Process Control & Safety Systems".

TRUSTED RELEASE

This technical manual applies to **Trusted Release: 3.6.1**.

LATEST PRODUCT INFORMATION

For the latest information about this product review the Product Notifications and Technical Notes issued by technical support. Product Notifications and product support are available at the Rockwell Automation Support Centre at <http://rockwellautomation.custhelp.com>

At the Search Knowledgebase tab select the option "By Product" then scroll down and select the Trusted product.

Some of the Answer ID's in the Knowledge Base require a TechConnect Support Contract. For more information about TechConnect Support Contract Access Level and Features please click on the following link:

https://rockwellautomation.custhelp.com/app/answers/detail/a_id/50871

This will get you to the login page where you must enter your login details.

IMPORTANT A login is required to access the link. If you do not have an account then you can create one using the "Sign Up" link at the top right of the web page.

DOCUMENTATION FEEDBACK

Your comments help us to write better user documentation. If you discover an error, or have a suggestion on how to make this publication better, send your comment to our technical support group at <http://rockwellautomation.custhelp.com>

SCOPE

This manual specifies the maintenance requirements and describes the procedures to assist troubleshooting and maintenance of a Trusted system.

WHO SHOULD USE THIS MANUAL

This manual is for plant maintenance personnel who are experienced in the operation and maintenance of electronic equipment and are trained to work with safety systems.

SYMBOLS

In this manual we will use these notices to tell you about safety considerations.



SHOCK HAZARD: Identifies an electrical shock hazard. If a warning label is fitted, it can be on or inside the equipment.



WARNING: Identifies information about practices or circumstances that can cause an explosion in a hazardous environment, which can cause injury or death, property damage or economic loss.



ATTENTION: Identifies information about practices or circumstances that can cause injury or death.



CAUTION: Identifies information about practices or circumstances that can cause property damage or economic loss.



BURN HAZARD: Identifies where a surface can reach dangerous temperatures. If a warning label is fitted, it can be on or inside the equipment.



This symbol identifies items which must be thought about and put in place when designing and assembling a Trusted controller for use in a Safety Instrumented Function (SIF). It appears extensively in the Trusted Safety Manual.

IMPORTANT

Identifies information that is critical for successful application and understanding of the product.

NOTE

Provides key information about the product or service.

TIP

Tips give helpful information about using or setting up the equipment.

WARNINGS AND CAUTIONS

**WARNING: EXPLOSION RISK**

Do not connect or disconnect equipment while the circuit is live or unless the area is known to be free of ignitable concentrations or equivalent

**AVERTISSEMENT - RISQUE D'EXPLOSION**

Ne pas connecter ou déconnecter l'équipement alors qu'il est sous tension, sauf si l'environnement est exempt de concentrations inflammables ou équivalente

**MAINTENANCE**

Maintenance must be carried out only by qualified personnel. Failure to follow these instructions may result in personal injury.

**CAUTION: RADIO FREQUENCY INTERFERENCE**

Most electronic equipment is influenced by Radio Frequency Interference. Caution should be exercised with regard to the use of portable communications equipment around such equipment. Signs should be posted in the vicinity of the equipment cautioning against the use of portable communications equipment.

**CAUTION:**

The module PCBs contains static sensitive components. Static handling precautions must be observed. DO NOT touch exposed connector pins or attempt to dismantle a module.

ISSUE RECORD

Issue	Date	Comments
1	July 04	
2	Nov 04	
3	Apr 05	Removed CS from Con 3, added section 6.1
4	Sep 05	Format
5	Feb 06	Fault relay details added.
6	Apr 07	Inrush current details added
7	Nov 07	Current sharing
8	Sep 08	TC-323 clarification
9	Sep 08	Current sharing with low loads
10	Sep 15	Rebranded and reformatted with Corrections to the Operating Temperature and Relative Humidity Range statements in the Specifications Section
11	APR 16	Document Updated to incorporate IEEE standards and to correct typographical errors

Page intentionally left blank

Table of Contents

1.	Product Range	3
2.	Assembly	5
3.	Power Shelf Specification	7
3.1.	Input Connector	7
3.2.	Output Connector	8
3.3.	Current Sharing	8
3.4.	Interface Connector	8
3.5.	Stacked-up Assembly	11
4.	Power Pack Specifications.....	13
4.1.	Power Pack Features	13
4.1.1.	Indicators	13
4.1.2.	Overcurrent Protection	14
4.1.3.	MCB Discrimination	14
4.2.	Input Specification	15
4.3.	Line Harmonics.....	15
4.4.	Efficiency and Power Factor vs. Input Voltage at Full Load	16
4.5.	Output Specification	16
4.6.	Environmental Characteristics	18
4.7.	Power Pack Hot Replacement.....	20
5.	Power Port.....	21
5.1.	General Description	21
5.2.	Circuit Description.....	22
5.2.1.	Supply	22
5.2.2.	DC Alarms	22
5.2.3.	AC Alarms	22
5.2.4.	Jumpers	23
5.3.	Mechanical	24
5.3.1.	Pin-out CON 1, CON 2.....	24
5.3.2.	Pin-out CON 3	25
5.3.3.	Fault Relay Technical Specifications.....	26
6.	Power Controller	27
6.1.	Power Up Sequence	28

7.	Power Shields	29
8.	Power Shelf Interconnect	31
9.	Power System Specification	33

1. Product Range

Catalogue No.	Product name	Description
T8230	Power Shelf	19 inch x 1U chassis for up to 3 Power Packs. Includes 4U fixing kit, Power Port (with push fit BLZF 3.5/10 connector), mains plugs and retaining clips.
T8231	Power Pack 24 Vdc	750 W, universal input, 24 Vdc out.
T8232	Power Pack 28 Vdc	750 W, universal input, 28 Vdc out.
T8233	Power Port	Plug in diagnostic interface.
T8234	Power Controller	For live adjustment of output voltage. 19 inch x 1U.
T8235	Power Shield	Covers unused Power Pack positions.
TC-323	Power Shelf Interconnect	For connection to a Power Controller or for current sharing.

Table 1 T823X Power System Product Range



Figure 1 Front View - Power Shelf with Power Packs



Figure 2 Rear View - Power Shelf, Power Port (uncovered) and 4U Mounting Brackets

2. Assembly

A pair of brackets mounted in to a 19 inch frame supports up to 4 Power Shelves and are required to provide support at the rear of the Power Shelf.

The brackets supplied mount the equipment by its 19 inch rack ears and provide a box structure to brace the power supplies. The back of the power supplies are fixed using M3.5 screws that are fixed via tapped holes in the Power Shelf. The front of the Power Shelf is located and supported via screws through the lugs of the Power Shelf.

The mounting bracket occupies 4U and can accommodate up to 4 Power Shelves. The design is such that no space outside the 4U aperture is required. When installed it is possible to remove individual Power Shelves should this be required. The design of the mounting bracket does not obstruct access to the front or back of the Power Tray.

Power Packs are slotted into the 1U Power Shelf with the first Power Pack in the right hand slot, as shown in Figure 4. Each Power Pack provides 750 W (31.25 A at 24 Vdc) to the DC output on the Power Shelf.

The standard AC input connection to the Power Shelf is through IEC 60320 type connectors rated at 10 A/250 Vac in Europe/Asia and 15A/120 Vac in North America.



Figure 3 AC Power Connectors and Retaining Clips

Output terminal blocks on each Power Shelf have three M4 screw connections. Ring type connectors should be used when connecting from the Power Shelf to system power distribution busbars.

The Power Port plugs into the back of the Power Shelf and requires a 24 V supply. The Power Port can provide monitoring and control via a 25 way D connector when connected to a Power Controller. A separate connector (CON3) via a push fit connector (supplied), provides DC and AC fail contacts. When more than one Power Shelf is used, Power Ports are linked via the CS terminal, using a Power Shelf Interconnect cable to enable current sharing.

Spare slots in the Power Shelf are covered by Power Shields.

The 1U Power Controller is connected via the Power Port, using a TC-323 Power Shelf Interconnect ribbon cable, and allows live configuration of output voltage. The Power Controller can monitor up to 12 Power Packs in 4 Power Shelves. Each Power Shelf is identified by the Power Controller by selecting addresses on the Power Port as described in paragraph 5.2.4.

Unused slots in the 4U brackets may be used for other equipment or fitted with blanking plates.

Unused connectors on the TC-323 ribbon cable should be tied back and left unused.

3. Power Shelf Specification

The Power Shelf is designed to operate as a key element in a complete distributed Power System.

This Power Shelf can house up to three Power Packs, provides physical protection and a number of alarm and control features.

The Power Shelf can supply up to 1500 W of n+1 redundant power or up to 2250 W of total power depending on configuration of Power Packs. Four stacked Power Shelves can provide up to 9000 W total power.

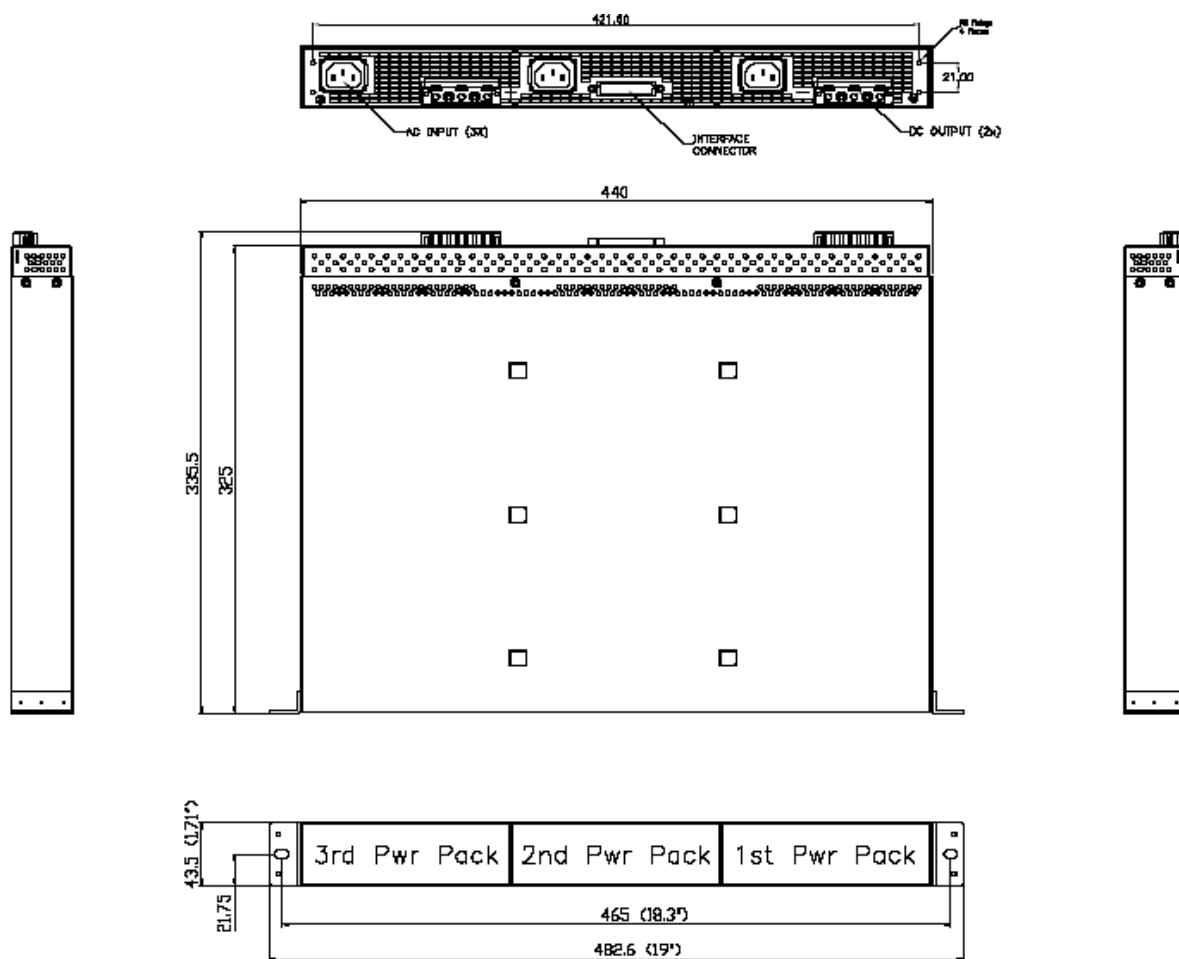

Figure 4 1U Power Shelf Mechanical Outline

3.1. Input Connector

The Power Shelf can be used with any standard global line voltages. The standard AC input connection to the Power Shelf is through three clip retained IEC 60320 type connectors rated at 10 A / 250 Vac in Europe/Asia and 15 A / 120 Vac in North America.

3.2. Output Connector

The Power Shelf has two terminal blocks for DC output (each with three M4 screws). The V+ and V- are floating with respect to frame GND, either of which can be connected to GND as required.

3.3. Current Sharing

Note: If there is a low load on a Power Shelf (less than 2 A per Power Pack) then the current sharing circuit may not work correctly and the 'PWR OK' LED may not illuminate on the Power Packs.

In systems where more than one Power Shelf is being used, Shelves should connect their CS terminals by using a Power Shelf Interconnect cable TC-323. This ensures that the Power Shelves current share.

Do not connect the TC-323 cable between 'A' and 'B' supplies or between two sets of Shelves which connect to separate busbars. The supplies will attempt to share current between the two busbars, which may damage the power packs and shelves' sensing circuits.

Unused connectors on the TC-323 cable should be tied back and left unused.

3.4. Interface Connector

The Power Shelf has an optional DSB, 25-pin, female interface connector on the back. The Power System can be monitored and controlled through this interface, by a Power Controller, using a Power Shelf Interconnect. AC and DC fail alarms are available from a separate connector on the Power Port.

Pin Number	Signal Name	Description
1	DC Fail_2	DC Fail signal of the second Power Pack
2	A2	I ² C address bit 2
3	A3	I ² C address bit 3
4	ON SYNC	Not Used
5	SDA	I ² C Serial data bus
6	SCL	I ² C Clock
7	NC	No connection
8	On/Off_1	Remote on off control for the first Power Pack - Not Used
9	OTP_1	Fan Fail or Over-temperature signal for the first Power Pack

Pin Number	Signal Name	Description
10	On/Off_2	Remote on off control for the second Power Pack - Not Used
11	V _{aux}	Not Used
12	DC Fail_1	DC Fail signal of the first Power Pack
13	AC Fail_3	AC Fail signal of the third Power Pack
14	OTP_3	Fan Fail or Over-temperature signal of the third Power Pack
15	DC Fail_3	DC Fail signal of the third Power Pack
16	INT BUS	Not used
17	AC Fail_1	AC Fail signal of the first Power Pack
18	On/Off_3	Remote on off control for third Power Pack - Not Used
19	SRTN	Signal return and V _{aux} return
20	RS-	Remote sense for V-
21	OTP_2	Fan Fail or Over-temperature signal of the second Power Pack
22	RS+	Remote sense for V+
23	AC Fail_2	AC Fail signal of the second Power Pack
24	CS	A single wire interface for current sharing
25	V-	V-

Table 2 Pin Assignment of the Interface Connector

Refer to Figure 4 - 1U Power Shelf Mechanical Outline for the locations of Power Pack 1, 2 and 3.

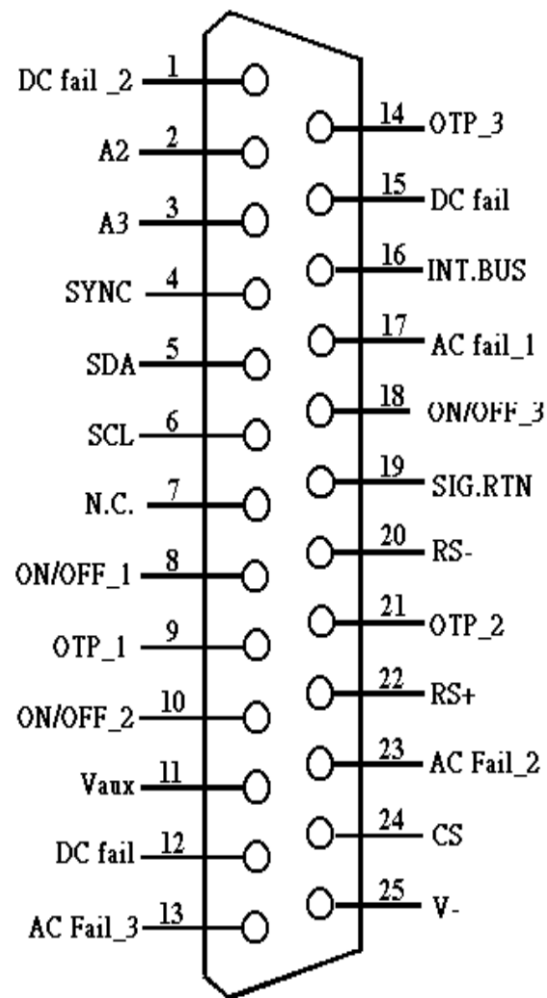

Figure 5 Interface Connector

3.5. Stacked-up Assembly

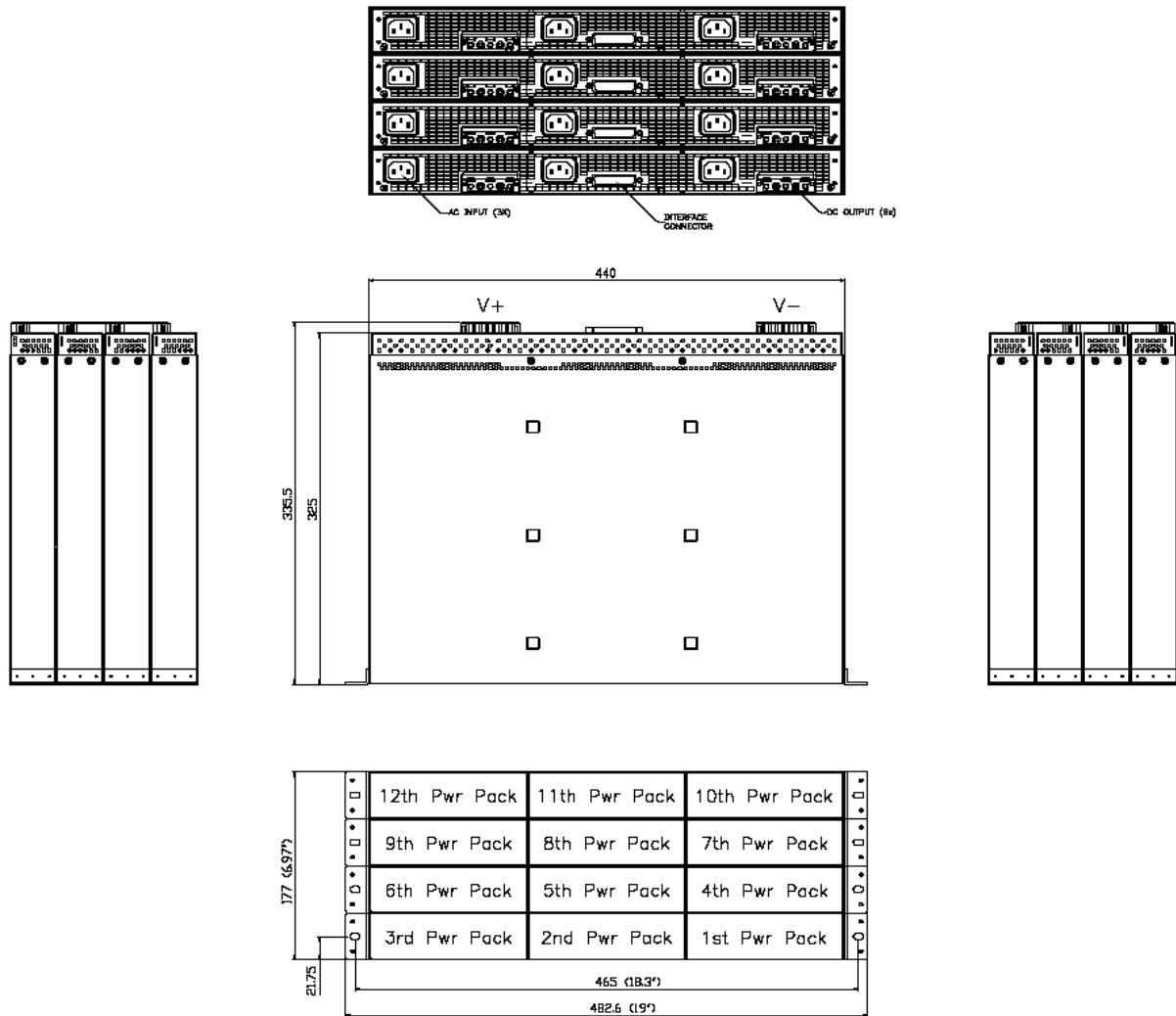

Figure 6 4U Stacked-up Assembly

Page intentionally left blank

4. Power Pack Specifications

The Power Pack is specifically designed to operate as an integral part of a complete distributed Power System.

A full complement of protection, alarm and control features has been incorporated into the Power Pack to provide versatility for use in many applications.

Power Packs can be inserted and removed when live, allowing ‘hot-swap’ of Power Packs (see section 4.7). They are secured using a physical latch on the front of the Power Pack which is pushed up to release or connect the Power Pack into the Power Shelf.

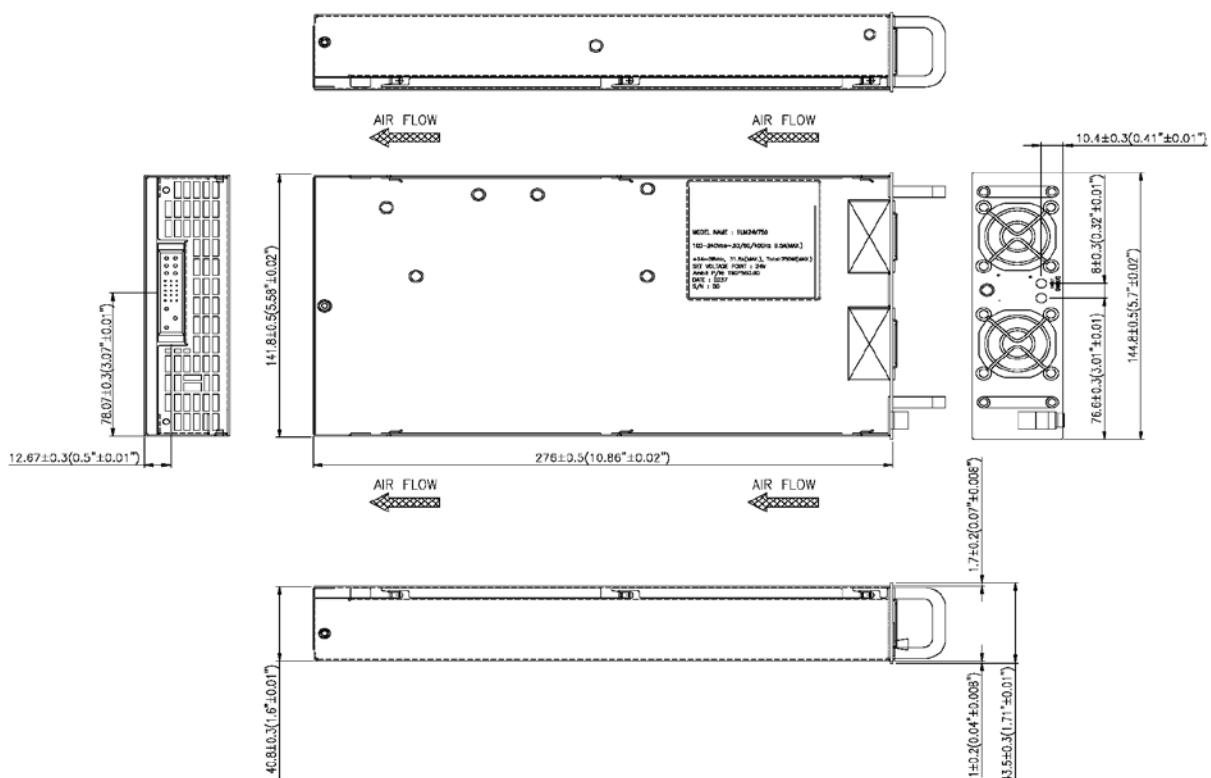

Figure 7 Power Pack Outline Drawing. Dimensions mm (inches)

4.1. Power Pack Features

4.1.1. Indicators

The Power Pack has two indicators on the front:

- AC OK: The LED is green if the input voltage is within limits.
- PWR OK: The LED is green if the Power Pack is healthy and within operating limits. If a fault occurs with the power supply or a fan, the LED is amber.

Failure of an internal Power Pack fan results in shutdown of the output of the Power Pack.

4.1.2. Overcurrent Protection

The over-current protection limits the output current in the event of an overload. There are two overload circumstances:

- If the load is increased steadily a single Power Pack compensates by derating the voltage, hence at 40 A (the specification limit) the voltage is derated to 18.75 V. This derated voltage is on the limit of the Trusted System Modules' specification.

• **Note:** This gradual increase is not typical of a system fault.

- If 24 V is maintained over a rapid current rise, the over-current protection will trip the power supply when 35 A is reached. This rapid increase is more typical of a fault situation in a system.

4.1.3. MCB Discrimination

Miniature circuit breaker (MCB) discrimination studies should be carried out when designing the system power distribution.

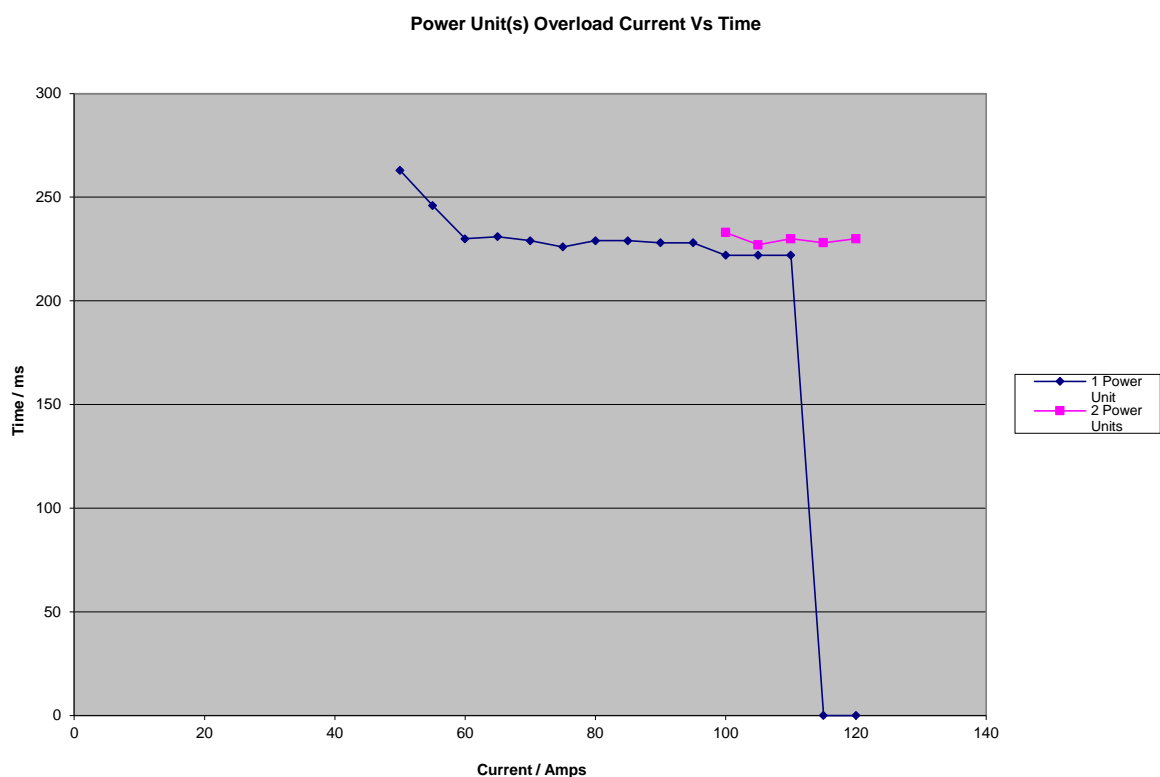

Figure 8 Power pack (s) Severe Overload Current v Time

The graph shows the response of a single Power Module to severe overloads. As the load is increased the power supply protection mechanism operates and shuts down the output. It can be seen that for a period of just in excess of 200 ms the Power Module can provide currents up to 115 A or 380 % of its stated maximum ($115/31 = 3.8$). This 200 ms/380 % can be extrapolated for additional power supplies in order to perform MCB discrimination studies.

4.2. Input Specification

Parameter	Min	Type	Max	Unit	Condition
Input Voltage	90		264	Vac	
Input Frequency	47		63	Hz	
Inrush Current (peak) per Pack			50	A	Full load
			<25	A	No load
Input current			0.2	A	No load
Power Factor	0.95	0.99			> 50 % of full load
Input Leakage Current			1.7	mA	264 Vac, 50Hz
Lighting Surge and Transients (damage free operation)					IEC 61000-4-5 Level 3
					IEC 61000-4-4 Level 3
Hold Up Time	20			ms	At 600 W
EMC (conducted)					CISPR22 Class B, EN 55022 Class B, with 3dB margin

Table 3 Input Specification

4.3. Line Harmonics

Active power factor correction circuitry ensures that this Power Pack meets the requirements of IEC 61000-3-2.

4.4. Efficiency and Power Factor vs. Input Voltage at Full Load

Input voltage	Efficiency (Typical)	Power Factor (Typical)
90 Vac	78 %	0.99
100 Vac	79 %	0.99
110 Vac	80 %	0.99
120 Vac	81 %	0.98
180 Vac	82 %	0.98
220 Vac	83 %	0.98
240 Vac	83 %	0.98
264 Vac	84 %	0.98

Table 4 Efficiency and Power Factor vs. Input Voltage at Full Load

When using this table to calculate cable feed requirements, allow, at a minimum, an extra 3 % for variations between units. Actual measured results will depend upon the harmonic content of the input voltage waveform.

4.5. Output Specification

Parameter	Min	Type	Max	Unit	Note
V_{OUT} Set Point:					
T8231		24		Vdc	
T8232		28		Vdc	
Regulation (line, load, temperature and set point)	-2		2	%	Measured at remote sense
Remote-sense Drop			0.5	Vdc	
I_{OUT} (rated):					
T8231 (24 V_{OUT})	0		31.25	Adc	750 W maximum
T8232 (28 V_{OUT})	0		26.78		
Ripple (20 MHz bandwidth)			150	mVp-p	

Parameter	Min	Type	Max	Unit	Note
Noise (20 MHz bandwidth)			300	mVp-p	Under any load conditions
Transmission Noise (C message)			45	dBmc	
Output Rise Time	10		100	ms	Rise from 10 % to 90 % of final output level (resistive load)
Over-voltage Protection	29		32	Vdc	Reset by cycling AC input, on/off, or reinsertion
Output Current Limit (steady state)			40A	Adc	
Transient Response Voltage Range	-2		2	%	25 % step load transient with slew rate 0.1 A/us within the range from 25 % to 75 % of full load
Active Current Sharing Differential			±3.2	A	Single wire current share at full load
Efficiency					
At full load, 120 Vac with ORing diode	80	81		%	
At full load, 264 Vac with ORing diode	83.5	84		%	
Reserve Output Current Protection					ORing diode
Start-up Delay		1.3	2	S	Measured from application of valid AC voltage
Turn-on Delay			250	ms	Measured from DC on/off

Table 5 Output Specification

4.6. Environmental Characteristics

Parameter	Min	Type	Max	Unit	Note
Storage Temperature	-40		-85	°C	
Operating Temperature (note 1)	0	-	60	°C	1. Derate at 1.333 %/°C, 45 °C to 50 °C 2. Derate at 4.667 %/°C, 50 °C to 60 °C
Acoustics		47	52	dBa	Sound Pressure Level at 1 m
Relative Humidity (non-condensing)	10		95	%	
Altitude	-60		3962	m	Derated at 2 °C/304 m above 2438 m
Electro Static Discharge					IEC 61000-4-2 Level 3 stand-alone
Electromagnetic Immunity (error free)					IEC 61000-4-3 Level 2 stand-alone
Isolation Voltage	3000 1500 1500			Vac Vac Vac	Primary to Secondary Primary to chassis GND, Secondary to chassis GND
MTBF	4 x 10 ⁵			hours	@110 Vinput 80 % load, T _A = 30°C
Vibration					Meet IEC 60068-2-6
Shock					Meet IEC 60068-2-27
Weight			2.3	kg	

Table 6 Environmental Characteristics

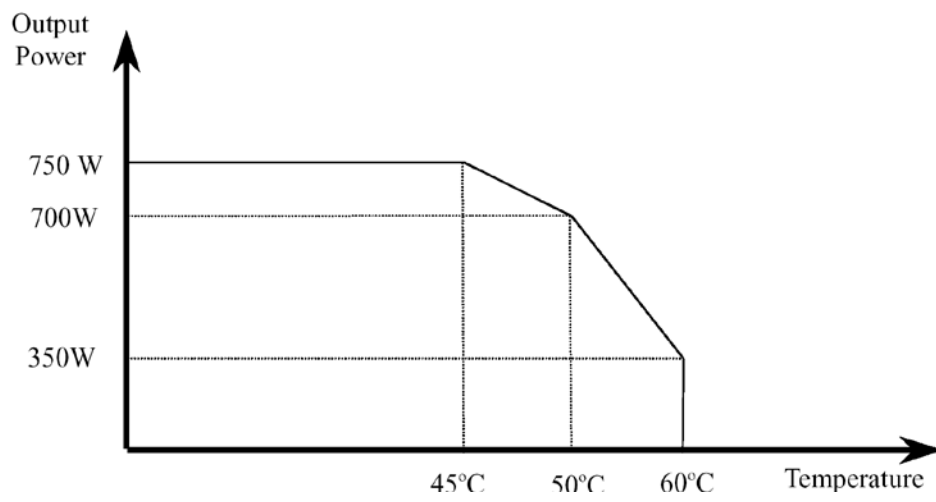
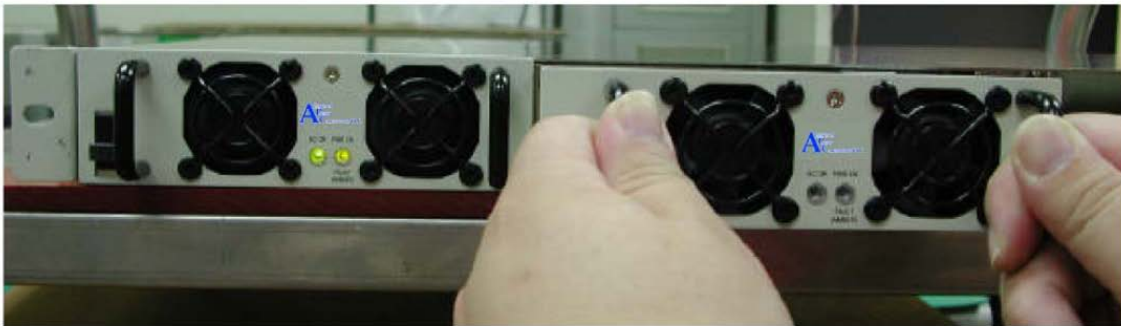

Figure 9 Operation Derating Curve

4.7. Power Pack Hot Replacement

1. Plug in slowly and smoothly.
2. Make sure the first set of pins are contacted – the AC OK LED will illuminate.
3. Push fully home - the PWR OK LED will illuminate.



Step 1 : Plug in smoothly and slowly.



Step 2 : Let the first set of pins contacted and AC OK LED is ON.



Step 3 : Push to fully contacted and PWR OK LED is ON.

Figure 10 Power Pack Hot Replacement

5. Power Port

5.1. General Description

The Power Port is a supplied accessory and is fitted onto the rear of the Power Shelf. It converts alarm signals produced by the Power Packs and Power Shelf into volt-free alarm contacts for use by the system and enables hot replacement of Power Packs. It consists of a PCB fitted with connectors, relays and miscellaneous electronic components. The shape and size of the Power Port is shown in Figure 11.

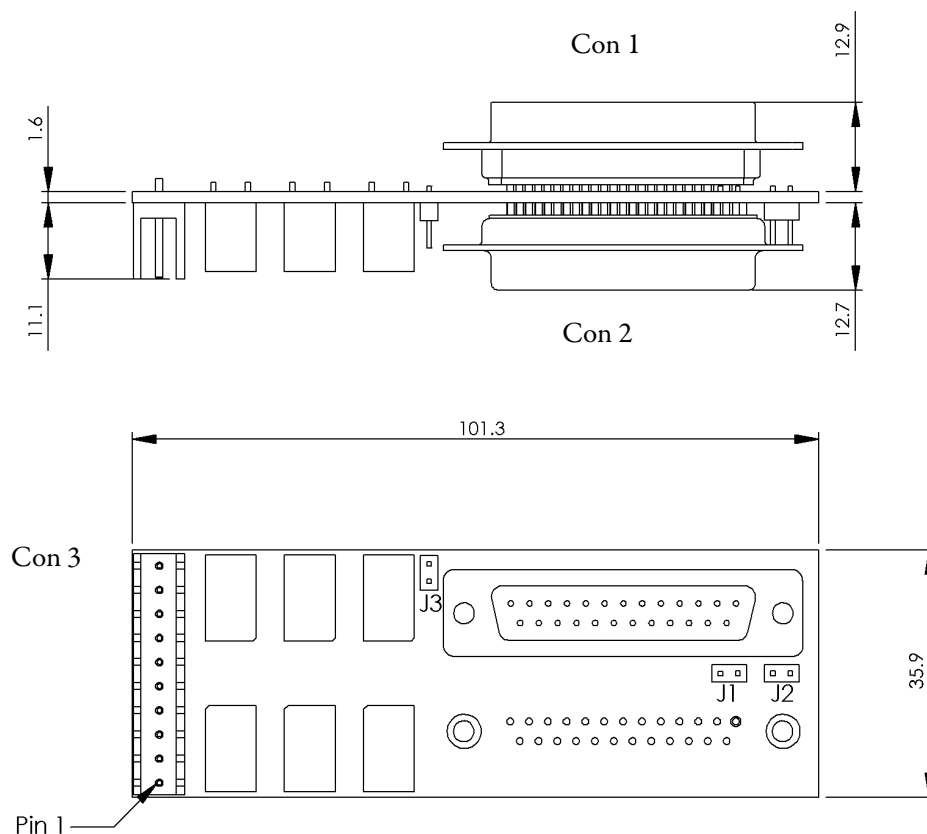

Figure 11 Power Port Outline Drawing

The alarm contacts are made available on a connector for ease of wiring into the system. The system provides a supply for the Power Port, which is wired to the same connector. The connector pin-outs are shown in section 5.3.

The Power Shelf is fitted with a 25 way D female connector to which the Power Port connects. The Power Port is retained to the Power Shelf by means of the Dsub jack screws. The Power Port is fitted with a 25 way D female connector to allow the Power Shelf

connectivity to be extended to a Power Controller using a Power Shelf Interconnect ribbon cable.

The Power Controller is powered from the Power Port 24 V supply via pin 7, when connecting CON 2 on the Power Port to the Power Controller.

5.2. Circuit Description

The circuit is split into four functional sections: supply, DC alarms, AC alarms and jumpers.

5.2.1. Supply

The 24 V supply is connected to CON3 pins 1 and 6. The supply should be fused close to its source, using a 500 mA F rated fuse. It is nevertheless protected by a non-replaceable fuse on the Power Port. The 24 V is regulated down to 5 V with decoupling provided. The 5 V+ is used to supply the low voltage electronics. The 24 V is used to supply the relays and is connected through CON2 to power the optional Power Controller.

5.2.2. DC Alarms

CON1 is the 25 way D male interface to the Power Shelf. The Power Pack and Power Shelf alarm outputs are derived from here. There are two DC alarms per Power Pack: DCFAIL (dc output fail) and OTP (over-temperature protection). The Power Port ORs together DCFAIL and OTP to give one DC fail alarm, via CON 3. If either alarm triggers, the corresponding relay de-energises.

Each relay operates a volt-free contact. These are closed when healthy (relay energised) and open in alarm. The contacts share a common return line.

5.2.3. AC Alarms

In a similar manner, each Power Pack generates an AC alarm. When an alarm is triggered, the corresponding relay de-energises. Each relay operates a volt-free contact. These are closed when healthy (relay energised) and open in alarm. The contacts share a common return line.

Fault Condition	Output OK LED	OTP Alarm	AC Fail Alarm	DC Fail Alarm	DC Output
No fault	Green	Low	Closed	Closed	ON
Fan locked rotor	Amber	Low	Closed	Closed	OFF
Secondary over temperature	Amber	High	Closed	Open	OFF
Primary over temperature	Off	High	Closed	Open	OFF
AC Feeder fail	Off	Low	Open	Open	OFF

Table 7 Alarm Conditions

5.2.4. Jumpers

There are three jumpers, J1, J2 and J3.

J1 and J2 set the Power Shelf address lines for the I²C control bus. With J1 and J2 fitted the Pack addresses are 1, 2 and 3, which is the default. Other addresses may be set by removing one or both of J1 and J2, up to 4 Shelves worth (or 12 Power Packs).

Power Shelf	J1	J2
1	fitted	fitted
2	fitted	removed
3	removed	fitted
4	removed	removed

Table 8 Power Shelf Addressing

J3 connects together the common return lines of the DC alarms and AC alarms. J3 is fitted by default.

5.3. Mechanical

5.3.1. Pin-out CON 1, CON 2

CON 1 on the Power Port connects to the Power Shelf. The pin-out details are shown in Table 2.

CON 2 is used to connect to other Power Shelves to current share or to connect to a Power Controller.

Pin Number	Signal Name	Description
1		
2		
3		
4	ON SYNC	Not Used
5	SDA	I2C Serial data bus
6	SCL	I2C Clock
7	24v	Supply from Power port
8		
9		
10		
11		
12		
13		
14		
15		
16	INT BUS	Not Used
17		
18		
19	SRTN	Signal return and V_{aux} return

Pin Number	Signal Name	Description
20	RS-	Remote sense for V-
21		
22	RS+	Remote sense for V+
23		
24	CS	Current Sharing
25	V-	V-

Table 9 Connected Pins on CON 2

5.3.2. Pin-out CON 3

Pin	Description
1	+24 V system supply
2	DCFAIL common
3	DCFAIL_3
4	DCFAIL_2
5	DCFAIL_1
6	0 V system supply return
7	ACFAIL_1
8	ACFAIL_2
9	ACFAIL_3
10	AC Fail common

Table 10 Connector 3 Pin-out

CON 3 provides volt-free alarm contacts as detailed in section 5.2.2 and 0 for use by the system and these are made available on a connector for ease of wiring into the system.

5.3.3. Fault Relay Technical Specifications

Contact Form	SPDT
Resistive Load	
at 125 Vac	0.5 A
at 24 Vdc	1 A
Max Switching Power	62.5 VA, 30 W
Rated Voltage	3 Vdc to 24 Vdc
Power Consumption	150 mW
Mechanical Endurance	5,000,000 operations minimum
Electrical Endurance	100,000 operations minimum
Operating Temperature	-40 °C to +70 °C (-40 °F to +158 °F)

6. Power Controller

The Power Controller is designed to control and monitor the 19 inch rack mount 1U high Power Shelf Units. It is used to address each Power Pack in turn and adjust the respective Power Pack voltage.

The Power Controller is a digital system and communicates with the Power Packs by means of a TC-323 Power Shelf Interconnect ribbon cable, via the Power Port. The shelf addresses are set using jumpers on the Power Port, as described in paragraph 5.2.4.

The Power Controller offers adjustment of the system voltage in 100 mV steps over the range 24-28 V for the Power Packs. Power supplies share through their analogue control circuitry. A Power Controller will ensure that a power supply, regardless of its voltage setting when plugged in, is adjusted (via the I²C serial data bus) to be within the current/voltage sharing window of the power supply's analogue control circuitry.

The front panel contains two switches. The Address switch is used to select a Power Pack. The Voltage switch is used to raise or lower the voltage of that Power Pack. The two displays show the current and voltage of that Power Pack.

Up to 12 hot swap Power Packs can be used in parallel. The Power Controller can be used to select a particular Power Pack's position and read the current being drawn from that unit with a resolution of 100 mA.

Note that the Power Controller should not be connected to power supplies on different busbars with the TC-323 cable, because it will attempt to perform load sharing between unconnected power supplies. It may also be presented with power supplies having duplicate addresses on its I²C bus.

Unused connectors on the TC-323 cable should be tied back and left unused.

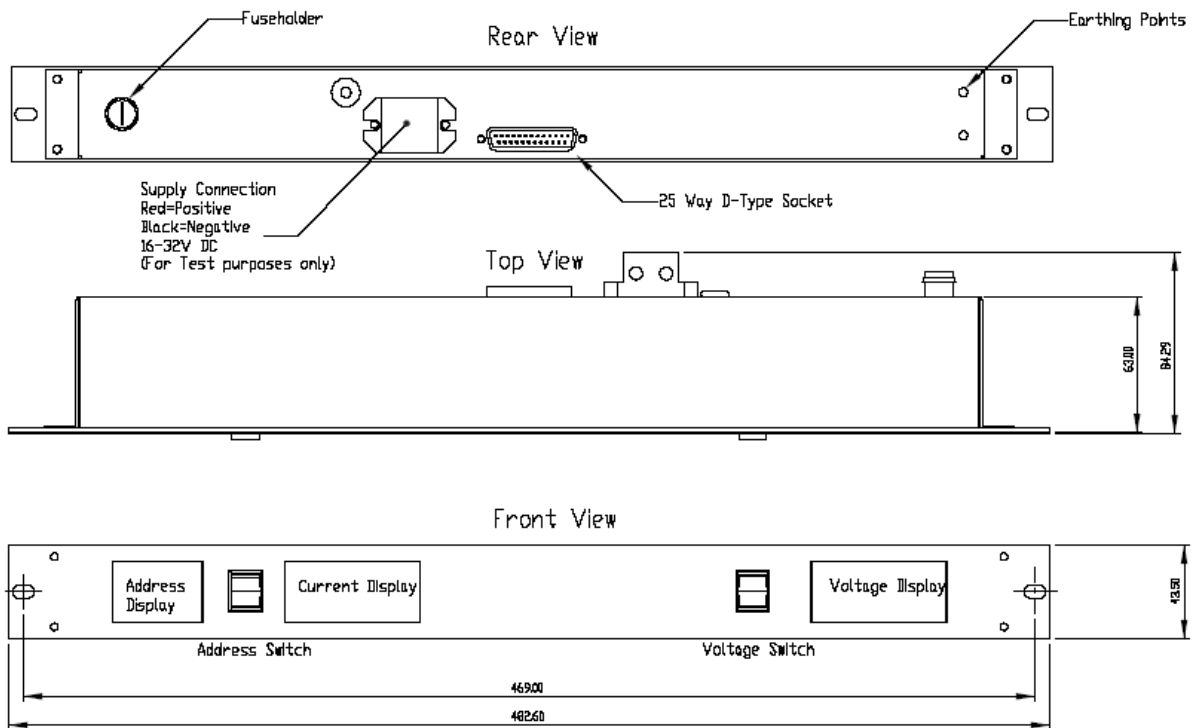

Figure 12 Power Controller Outline Drawing

6.1. Power Up Sequence

When a Power Controller is connected to more than one Power Shelf, Power Shelves should have their supplies applied in turn, e.g. power up first Shelf (idents 1-3), followed by Shelf two (idents 4-6) etc. This ensures that the Power Pack addresses are not duplicated.

7. Power Shields

If a Power Shelf is not fully populated, Power Shields are used to cover unused spare slots.

Page intentionally left blank

8. Power Shelf Interconnect

A ribbon cable is required to connect Power Shelves together in order to current share, or to connect shelves to a Power Controller.

The supplied ribbon cable has 5 connectors, to allow the maximum of 4 Shelves and a Power Controller to be connected.

Do not connect the TC-323 cable between 'A' and 'B' supplies or between two sets of Shelves which connect to separate busbars. The supplies will attempt to share current between the two busbars, which may damage the Power Packs and Shelves' sensing circuits.

Unused connectors on the TC-323 cable should be tied back and left unused.

Page intentionally left blank

9. Power System Specification

Voltage Range	
Input	90 Vac to 264 Vac
Output	24 Vdc to 28 Vdc
Frequency Range	47 Hz to 63 Hz
Inrush Current	50 A Max per Pack
Power Factor	0.95 min, 0.99 typical
Efficiency	78 % – 84 %
Output Power	750 W per Power Pack
Power Hold-up Time	20 ms
Operating Temperature	0 °C to +60 °C (+32 °F to +140 °F)
Relative Humidity range (operating, storage & transport)	10 % – 95 %, non-condensing
Environmental Specifications	Refer to Document 552517
Power Shelf Dimensions	
Height:	43 mm (1.71 in)
Width:	483 mm (19 in)
Depth:	340 mm (13.36 in)
Weight Data	
T8231,T8232 Power Pack	2.7 kg
T8230 Shelf (without supports)	4.4 kg
UL Approvals	
Power Supplies, Information Technology Equipment Including Electrical Business Equipment - Component	E223750
Power Supplies, Medical and Dental - Component	E223749